

GRANPASSO
1200



Catalogo Ricambi
Spare Parts Catalogue
Catalogue pièces détachées
Ersatzteilkatalog
Catalogo piezas de repuesto

Model Year 2008

**Catalogo Ricambi - *Spare Parts Catalogue*
Catalogue pièces détachées
Ersatzteilkatalog - Catalogo piezas de repuesto**

cod. M2144150

Edizione - *Edition* - Édition -
Ausgabe - Edición

11/08



I dati riportati nel presente catalogo, sono soggetti a modifica senza obbligo di tempestivo preavviso.

The information presented in this catalogue may be subject to change without prior notice.

Les données reportées dans ce catalogue peuvent à tout moment faire l'objet de modifications sans aucun préavis.

Die im vorliegenden Katalog aufgeführten Angaben können ohne Vorankündigung verändert werden.

Los datos del presente catalogo están sujetos a posibles modificaciones sin obligación de previo aviso.

INFORMAZIONI GENERALI

- Nelle ordinazioni di parti di ricambio, indicare sempre:

- N° di codice e descrizione del componente

- Quantità

- Specificare colore (quando richiesto)

- N° di matricola del motociclo (A - n° telaio - B - N° motore) (se richiesto)

- Ragione sociale ed indirizzo completo

- **Le indicazioni: DX** (destra) - **SX** (sinistra) si riferiscono al senso di marcia.

AVVERTENZE

- La MOTO MORINI S.p.A., si esime da qualsiasi responsabilità per danni di ogni natura, generati dall'impiego di ricambi non originali.

GENERAL INFORMATION

- *When ordering spare parts, please be sure to indicate:*

- *Code n° and component description*

- *Quantity*

- *Specified colour (when requested)*

- *Motorcycle serial n° (A - frame n° - B - frame n°) (if requested)*

- *Company name and complete address*

- **Directions: DX** (right) - **SX** (left) in reference to direction of travel.

DISCLAIMER

- *MOTO MORINI S.p.A., is exempt from any responsibility for damage of any kind caused by the use of non-original spare parts.*

INFORMATIONS GÉNÉRALES

- Dans les commandes de pièces de rechange, toujours indiquer:

- N° du code et description de la pièce

- Quantité

- Préciser la couleur (quand c'est demandé)

- N° d'immatriculation du motocycle (A - n° châssis - B - N° moteur) (si demandé)

- Siège social et adresse complète

- **Les indications DX** (droite) - **SX** (gauche) se réfèrent au sens de marche.

AVERTISSEMENT

- MOTO MORINI S.p.A., n'est en aucun cas responsable de dommages causés par l'utilisation de pièces de rechange non originales.

ALLGEMEINE INFORMATIONEN

- *Bitte folgende Daten bei der Bestellung von Ersatzteilen stets angeben:*

- *Artikelnummer und Beschreibung des Ersatzteils*

- *Anzahl*

- *Gewünschte Farbe (falls verlangt)*

- *Matrikelnummer des Kraftrads (A - Fahrgestellnummer - B - Motornummer) (falls verlangt)*

- *Komplette Bezeichnung von Empfänger und Anschrift*

- **Angaben: DX** (rechts) - **SX** (links) beziehen sich auf die Fahrtrichtung.

ACHTUNG

- *Die Firma MOTO MORINI S.p.A. übernimmt für Schäden, die durch die Verwendung nicht originaler Ersatzteile verursacht wurden, keinerlei Haftung.*

INFORMACIÓN GENERAL

- En los pedidos de piezas de repuesto se deben especificar:

- Código y descripción del componente

- Cantidades

- Color (si es requerido)

- Matrícula de la motocicleta (A - n° de bastidor - B - N° de motor) (si es requerido)

- Razón social y dirección completa

- **Las indicaciones: DX** (derecha) - **SX** (izquierda) toman como referencia el sentido de marcha.

ADVERTENCIAS

- MOTO MORINI S.p.A. no asumirá responsabilidad alguna frente a cualquier tipo de daño causado por la utilización de repuestos no originales.

TAB.	DESCRIZIONE	DESCRIPTION	DESCRIPTION	BESCHREIBUNG	DESCRIPCIÓN
A	Attrezzi speciali	<i>Special Tools</i>	Outils spéciaux	<i>Spezialwerkzeuge</i>	Herramientas especiales
001	Telaio	<i>Frame</i>	Cadre	<i>Rahmen</i>	Chasis
002	Carrozzeria	<i>Body</i>	Carrosserie	<i>Karosserie</i>	Carrocería
003	Serbatoio benzina	<i>Fuel tank</i>	Réservoir à essence	<i>Benzintank</i>	Tanque de gasolina
004	Impianto di raffreddamento	<i>Cooling system</i>	Installation de refroidiss.	<i>Kühlanlage</i>	Instalación de refrigeración
005	Manubrio e comandi	<i>Handlebar and controls</i>	Guidon et commandes	<i>Lenkrad</i>	Volante y mandos
006	Impianto elettrico	<i>Electrical devices</i>	Installation électrique	<i>Elektrik</i>	Instalación eléctrica
007	Dispositivi elettronici	<i>Electronic parts</i>	Dispositifs électroniques	<i>Elektronik</i>	Dispositivos electrónicos
008	Aspirazione	<i>Intake</i>	Aspiration	<i>Ansaugung</i>	Aspiración
009	Scarico	<i>Exhaust</i>	Echappement	<i>Vergaser</i>	Descarga
010	Pedana pilota destra	<i>Driver right rear footpeg</i>	Repose-pied pilote dt	<i>Fahrertrittbrett rechts</i>	Plataforma piloto der.
011	Pedana pilota sinistra	<i>Driver left rear footpeg</i>	Repose-pied pilote gche	<i>Fahrertrittbrett links</i>	Plataforma piloto izq.
012	Pedana passeggero dx	<i>Right passanger footpeg</i>	Repose pied droit passager	<i>Beifahrertrittbrett rechts</i>	Plataforma pasajero der.
013	Pedana passeggero sx	<i>Right passanger footpeg</i>	Repose-pied gche passager	<i>Beifahrertrittbrett links</i>	Plataforma pasajero izq.
014	Forcella	<i>Fork</i>	Fourche	<i>Gabel</i>	Horquilla
015	Forcellone/Ammortizzatore	<i>Swing arm/Shock absorber</i>	Bras oscillant/Amortisseur	<i>Federbein/Stoßdämpfer</i>	Horquilla/Amortiguador
016	Cavalletto laterale	<i>Side stand</i>	Béquille latérale	<i>Seitenständer</i>	Caballote lateral
017	Ruota anteriore	<i>Front wheel</i>	Roue avant	<i>Vorderrad</i>	Rueda delantera
018	Ruota posteriore	<i>Rear wheel</i>	Roue arrière	<i>Hinterrad</i>	Rueda trasera
019	Carter e imbiellaggio	<i>Casing and connecting rod</i>	Carter et vilebrequin	<i>Gehäuse und Pleuel</i>	Cárter y acoplamiento de bielas
020	Testa	<i>Motor head</i>	Culasse	<i>Kopfstück</i>	Culata
021	Distribuzione	<i>Timing</i>	Distribution	<i>Verteiler</i>	Distribución
022	Accensione	<i>Ignition</i>	Allumage	<i>Zündung</i>	Encendido
023	Lubrificazione	<i>Lubrication</i>	Graissage	<i>Schmierung</i>	Lubricación
024	Raffreddamento	<i>Cooling system</i>	Refroidissement	<i>Kühlung</i>	Refrigeración
025	Alimentazione	<i>Feeding circuit</i>	Alimentation	<i>Versorgung</i>	Alimentación
026	Cambio	<i>Gearbox</i>	Boîte de vitesses	<i>Schaltung</i>	Cambio
027	Frizione	<i>Clutch</i>	Embrayage	<i>Kupplung</i>	Embrague

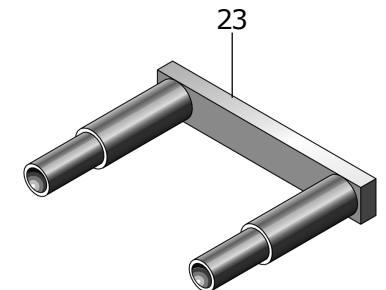
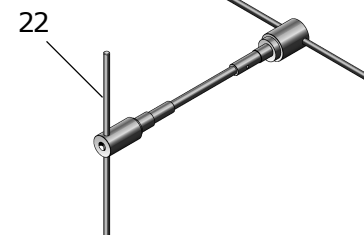
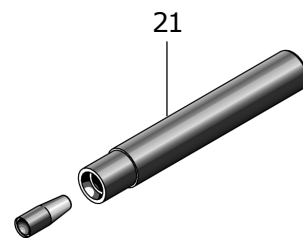
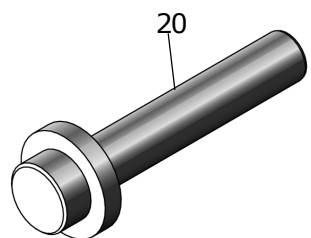
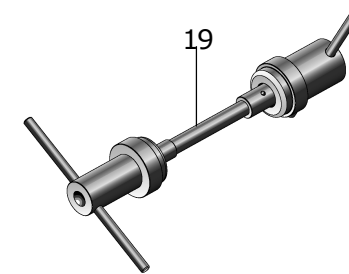
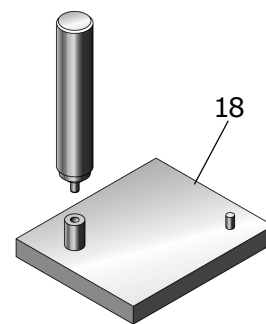
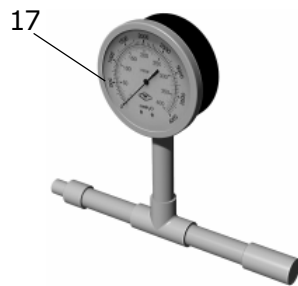
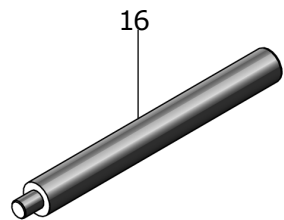
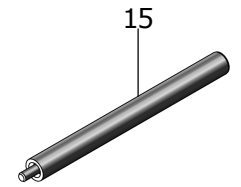
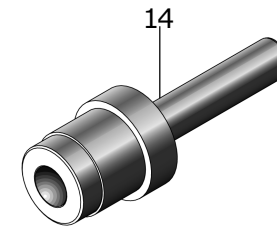
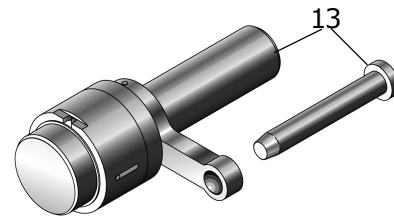
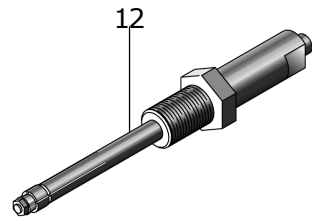
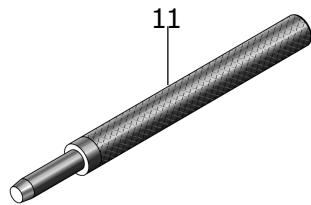
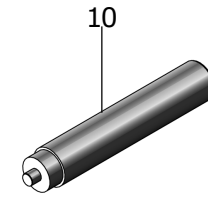
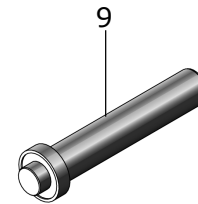
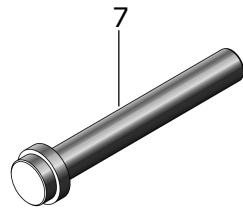
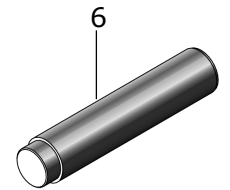
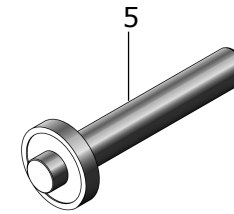
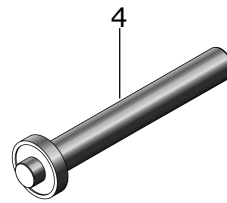
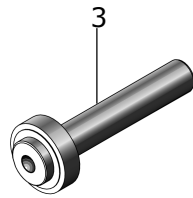
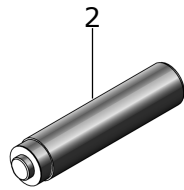
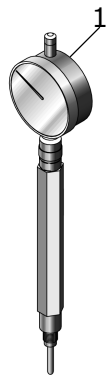

N°	Cod.	Q.	Descrizione	Description	Description	Beschreibung	Descripción
1	M00100010400	1	Orologio misuratore	<i>Gauge clock</i>	Horloge mesureur	<i>Messuhr</i>	Reloj medidor
2	M00100011400	1	Tampone anello tenuta cop. volano	<i>Flywheel cover seal ring buffer</i>	Amortisseur bague d'étanchéité cop. volant moteur	<i>Puffer Dichtring Schwungrad</i>	Tampón anillo de estanqueidad cub. volante
3	M00100004400	1	Tampone anello tenuta albero sec.	<i>Transmission shaft seal ring buffer</i>	Amortisseur bague d'étanchéité arbre sec	<i>Puffer Dichtring Zweitwelle</i>	Tampón anillo de estanqueidad eje sec.
4	M00100012400	1	Tampone cuscinetto 20x47x14 (cambio)	<i>Bearing buffer 20x47x14 (gearbox)</i>	Amortisseur coussinet 20x47x14 (boîte de vitesses)	<i>Puffer Lager 20x47x14 (Schaltung)</i>	Tampón cojinete 20x47x14 (cambio)
5	M00100013400	1	Tampone cuscinetto 28x68x17 (cambio)	<i>Bearing buffer 28x68x17 (gearbox)</i>	Amortisseur coussinet 28x68x17 (boîte de vitesses)	<i>Puffer Lager 28x68x17 (Schaltung)</i>	Tampón cojinete 28x68x17 (cambio)
6	M00100040400	1	Tampone cuscinetto rinvio distrib.	<i>Timing lay bearing buffer</i>	Amortisseur coussinet renvoi distrib.	<i>Puffer Lager Verteiler Rücklauf</i>	Tampón cojinete retorno distrib.
7	M00100014400	1	Tampone gabbia rulli Desmo	<i>Desmodromic roller cage buffer</i>	Amortisseur cage de roulement Desmo	<i>Puffer Rollenkäfig Desmo</i>	Tampón cojinete de rodillos Desmo
8	M00100015400	1	Tampone gabbia rulli rinvio distrib.	<i>Timing lay roller cage buffer</i>	Amortisseur cage de roulement renvoi distrib.	<i>Puffer Rollenkäfig Verteiler Rücklauf</i>	Tampón cojinete de rodillos retorno distrib.
9	M00100016400	1	Tampone cuscinetto Desmo	<i>Desmodromic bearing buffer</i>	Amortisseur coussinet Desmo	<i>Puffer Lager Desmo</i>	Tampón cojinete Desmo
10	M00100017400	1	Tampone anello tenuta albero prim.	<i>Driving shaft seal ring buffer</i>	Amortisseur bague d'étanchéité arbre prim.	<i>Puffer Dichtring Hauptwelle</i>	Tampón anillo de estanqueidad eje prim.
11	M00100018400	1	Tampone spinotto pistone	<i>Piston pin buffer</i>	Amortisseur axe de piston	<i>Puffer Kolbenbolzen</i>	Tampón bulón pistón
12	M00100019400	1	Estrattore spinotto pistone	<i>Piston pin puller</i>	Extracteur axe de piston	<i>Kolbenbolzen -Abzieher</i>	Extractor bulón pistón
13	M00100020400	1	Tampone inserimento bronzine	<i>Bearing entry buffer</i>	Outil pour l'introduction des coussinets	<i>Puffer Gleitlager</i>	Tampón introducción cojinetes del eje
14	M00100021400	1	Tampone sfilamento bronzine	<i>Bearing extraction buffer</i>	Outil pour l'extraction des coussinets	<i>Puffer Gleitlager</i>	Tampón extracción cojinetes del eje
15	M00100038400	1	Tampone anello raschiaolio	<i>Scraper ring buffer</i>	Amortisseur anneau racleur d'huile	<i>Puffer Kolbenringabstreifer</i>	Tampón aro rascador de aceite
16	M00100023400	1	Tampone bussole carter	<i>Cover guard bush buffer</i>	Amortisseur boussoles douilles carter	<i>Puffer Buche Schutzverkleidung</i>	Tampón casquillos carter
17	M00100044400	1	Manometro pressione benzina	<i>Fuel pressure gauge</i>	Manomètre pression essence	<i>Benzin-Druckmesser</i>	Manómetro presión gasolina
18	M00100025400	1	Base premontaggio coperchio selettore	<i>Gear shift cover guard pre-assembly base</i>	Base prémontage couvercle sélecteur	<i>Vormontage-Aufsatz Schalterabdeckung</i>	Base premontaje tapa selector
19	M00100046400	1	Tampone cuscinetto sterzo su telaio	<i>Steering bearing buffer - on frame</i>	Amortisseur coussinet direction sur châssis cadre	<i>Puffer Lenkerlager auf Rahmen</i>	Tampón cojinete dirección en chasis
20	M00100026400	1	Tampone gabbie rulli (frizione)	<i>(Clutch) roller cage buffer</i>	Amortisseur cages de roulement (embrayage)	<i>Puffer Rollenkäfig (Kupplung)</i>	Tampón cojinetes de rodillos (embrague)
21	M00100001400	1	Tampone anello tenuta rinvio distrib.	<i>Timing lay seal ring buffer</i>	Amortisseur bague d'étanchéité renvoi distrib.	<i>Puffer Dichtring Verteiler Rücklauf</i>	Tampón anillo de estanqueidad retorno distrib.
22	M00100049400	1	Attrezzo per cuscinetti forcellone	<i>Tool for the sing arm bearings</i>	Outil pour coussinets bras oscillant	<i>Vorrichtung für Federbeinlager</i>	Herramienta para cojinetes basculantes
23	M00100028400	1	Guida posizionamento bielle	<i>Connecting rod positioning guides</i>	Dispositif de guidage positionnement bielles	<i>Ausrichtungsschiene Pleuel</i>	Guía posicionamiento bielas



GRANPASSO
1200

Attrezzi Speciali - Special Tools - Outils speciaux - Spezialwerkzeuge
Herramientas especiales

A

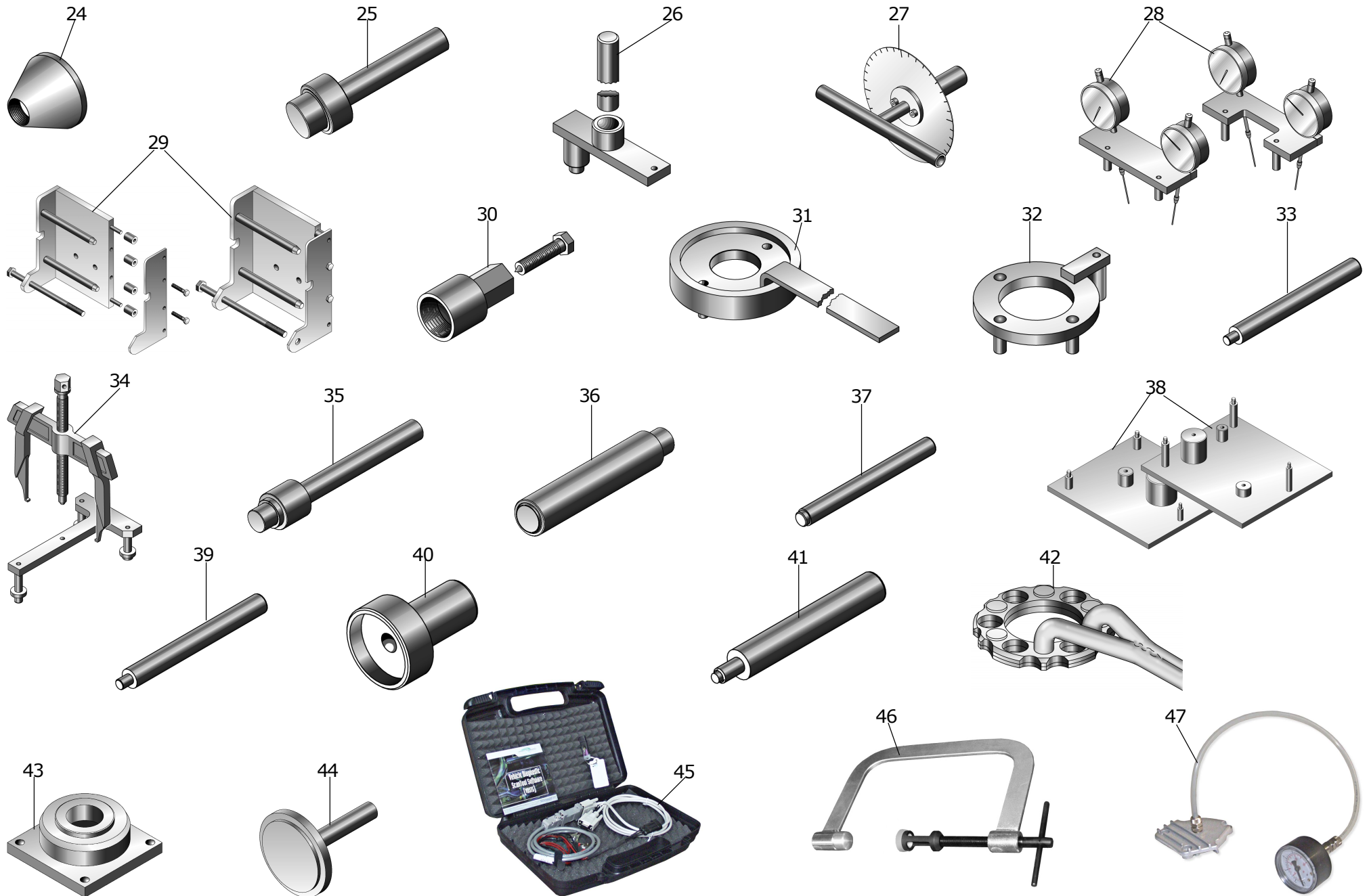

N°	Cod.	Q.	Descrizione	Description	Description	Beschreibung	Descripción
24	M00100029400	1	Busta protezione bronzine	<i>Bearing protection envelope</i>	Ecrou de protection coussinets	<i>Schutzhülle Gleitlager</i>	Bolsa de protección cojinete del eje
25	M00100048400	1	Tampone cuscinetto portacorona	<i>Sprocket bearing buffer</i>	Amortisseur coussinet porte-couronne	<i>Puffer Lager Trägerkranz</i>	Tampón cojinete portacorona
26	M00100030400	1	Tampone + guida spina selettore	<i>Buffer + gear shift pin guide</i>	Amortisseur + dispositif de guidage fiche sélecteur	<i>Puffer + Schiene Schalterstift</i>	Tampón + guía clavija selector
27	M00100031400	1	Disco goniometrico per fase	<i>Timing goniometric disc</i>	Disque goniométrique pour phase	<i>Goniometrische Scheibe für Phasen</i>	Disco goniométrico para fase
28	M00100032400	1	Misuratore alzata valvole (fase)	<i>Valve upwards motion gauge (timing)</i>	Mesureur de levée de soupape (phase)	<i>Ventilöffnungsmesser (Phase)</i>	Medidor elevación válvulas (fase)
29	M00100033400	1	Supporto motore	<i>Engine support</i>	Support moteur	<i>Motorträger</i>	Soporte motor
30	M00100002400	1	Estrattore volano	<i>Flywheel puller</i>	Extracteur volant	<i>Schwungradabzieher</i>	Extractor volante
31	M00100006400	1	Antiritrazione rotore volano	<i>Flywheel anti-rotation rotor</i>	Antirotation rotor volant	<i>Gegendrehung Scgwngrad</i>	Antirrotación rotor volante
32	M00100003400	1	Antiritrazione pignone catena	<i>Flywheel anti-rotation sprocket</i>	Antirotation pignon de chaîne	<i>Gegendrehung Kettenantriebsrad</i>	Antirrotación piñón cadena
33	M00100034400	1	Tampone raccordo mandata olio	<i>Oil delivery connector buffer</i>	Amortisseur raccord refoulement huile	<i>Puffer Anschlussstück Ölspesung</i>	Tampón racor inyección aceite
34	M00100035400	1	Estrattore canna cilindro	<i>Cylinder stem puller</i>	Extracteur fût de cylindre	<i>Zylinderstababzieher</i>	Extractor cuerpo cilindro
35	M00100047400	1	Tampone cuscinetto bilanciere	<i>Rocker bearing buffer</i>	Amortisseur coussinet culbuteur	<i>Puffer Lager Kipparm</i>	Tampón cojinete balancín
36	M00100045400	1	Tampone cuscinetto sterzo su forcella	<i>Steering bearing buffer on the fork</i>	Amortisseur coussinet direction sur fourche	<i>Puffer Lager Gabellenkung</i>	Tampón cojinete dirección en horquilla
37	M00100022400	1	Tampone tappo otturatore 13 mm	<i>Buffer for closing plug 13 mm</i>	Amortisseur bouchon obturateur 13 mm	<i>Puffer Stopferdeckel 13 mm</i>	Tampón tapón obturador 13 mm
38	M00100041400	1	Supporti per premontaggio semicarter centrale e volano	<i>Support for the pre-assembly of the cover guard</i>	Supports pour prémontage demi-carter central et volant	<i>Halterung für Vormontage von mittlerer Schutzverkleidung und Schwungrad</i>	Soportes para premontaje semicárter central y volante
39	M00100043400	1	Tampone boccola asta frizione	<i>Clutch rod bushing drift</i>	Amortisseur bague tige d'embrayage	<i>Puffer Buche Kupplungshebel</i>	Tampón casquillo eje embrague
40	M00100037400	1	Tampone seeger ingranaggio pompa olio	<i>Oil pump gear circlip bedding buffer</i>	Amortisseur circlip engrénage pompe à huile	<i>Seeger Puffer Ölpumpenantriebsrad</i>	Tampón seeger engranaje bomba de aceite
41	M00100039400	1	Tampone tappo otturatore 8 mm	<i>Buffer for closing plug 8 mm</i>	Amortisseur bouchon obturateur 8 mm	<i>Puffer Stopferdecke 8 mm</i>	Tampón tapón obturador 8 mm
42	M00100042400	1	Antiritrazione frizione	<i>Clutch anti-rotation device</i>	Anti-rotation embrayage	<i>Gegendrehung Kupplung</i>	Antirrotación embrague
43	M00100052400	1	Supporto semicarter centrale	<i>Central casing support</i>	Support demi-carter central	<i>Halterung mittlere Schutzverkleidung</i>	Soporte semicárter central
44	M00100051400	1	Tampone inserimento canna cilindro	<i>Cylinder stem entry buffer</i>	Amortisseur insertion fût de cylindre	<i>Puffer Zylinderstabeinsatz</i>	Tampón introducción cuerpo cilindro
45	M00800001000	1	Tools di diagnosi	<i>Engine diagnosis</i>	Outils de diagnostic	<i>Fehlererkennungs- Tools</i>	Herramientas de diagnóstico
46	M00100053400	1	Smontaggio valvole	<i>Valves disassembly</i>	Démontage des soupapes	<i>Ventilausbau</i>	Desmontaje válvulas
47	M00200013000	1	Misuratore pressione olio	<i>Pressure oil gauge</i>	Appareil de mesure de pression	<i>Druckmesser</i>	Medidor de presión



GRANPASSO
1200

Telaio - Frame - Cadre - Rahmen - Chassis

001

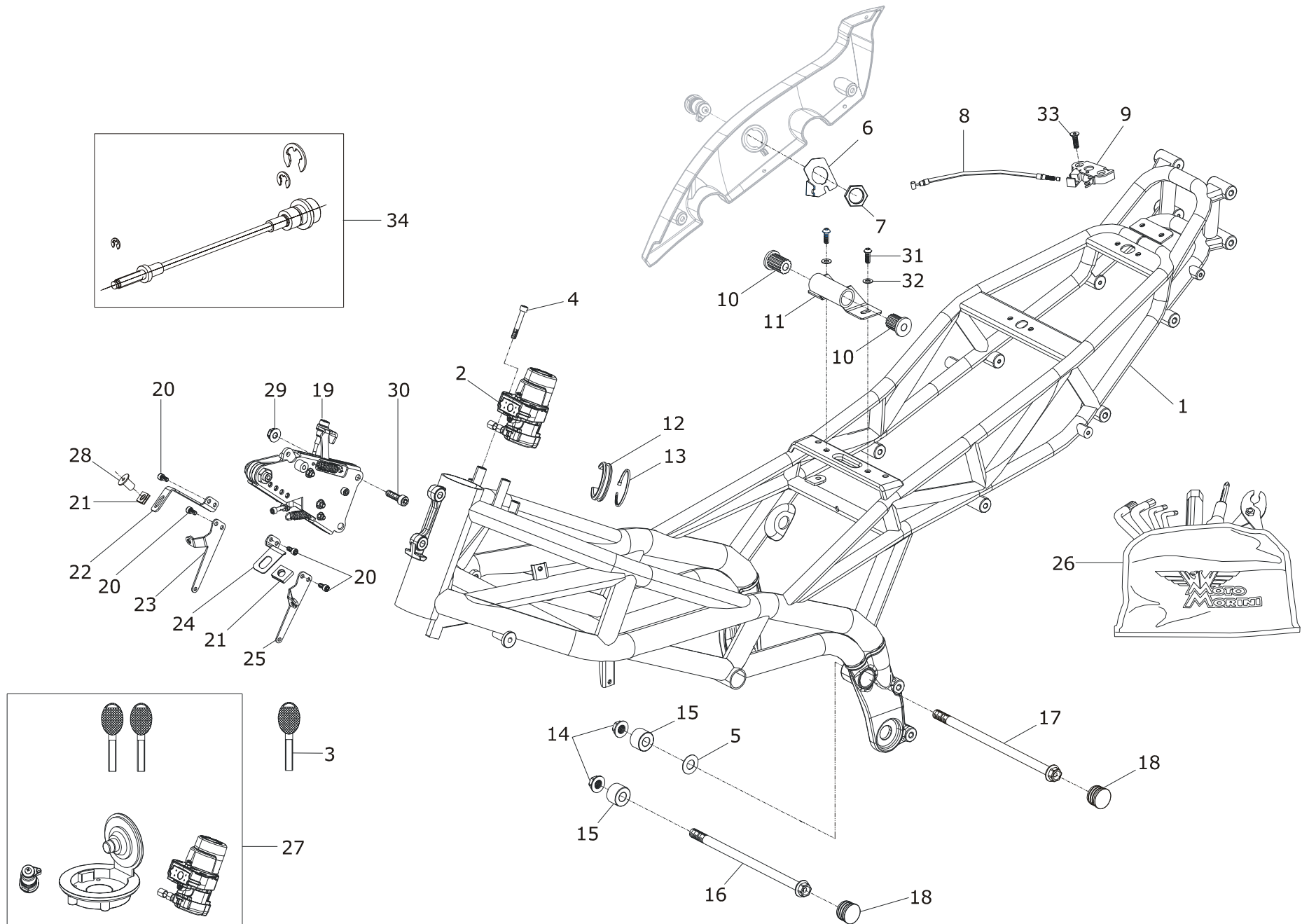

N°	Cod.	Q.	Descrizione	Description	Description	Beschreibung	Descripción
* 1	M2137011 - - -	1	Telaio	<i>Chassis</i>	Cadre	<i>Rahmen</i>	Chasis
2	M30200001400	1	Commutatore bloccasterzo	<i>Steering lock switch</i>	Commutateur verrou de direction	<i>Wechselschalter Lenkersperre</i>	Conmutador bloqueo dirección
3	M30300002000	1	Chiave singola non cifrata	<i>Uncripted single key</i>	Clé unique non chiffrée	<i>Einzelschlüssel nicht chiffriert</i>	Llave individual no cifrada
4	M01000048401	2	Vite antimanomissione M8X30	<i>Security Screw M8X30</i>	Vis M8X30 inviolabile	<i>Manipulationssichere Schraube M8X30</i>	Tornillo M8X30 antirrobo
5	M009900504	1	Rondella spessore 0.4	<i>Washer shim 0.4</i>	Rondelle épaisseur 0.4	<i>Unterlegscheibe Distanzstück 0.4</i>	Arandela espesor 0.4
5	M009900508	1	Rondella spessore 0.8	<i>Washer shim 0.8</i>	Rondelle épaisseur 0.8	<i>Unterlegscheibe Distanzstück 0.8</i>	Arandela espesor 0.8
5	M009900510	1	Rondella spessore 1.0	<i>Washer shim 1.0</i>	Rondelle épaisseur 1.0	<i>Unterlegscheibe Distanzstück 1.0</i>	Arandela espesor 1.0
6	M15600002404	1	Staffa supporto serratura sella	<i>Seat lock bracket</i>	Étrier de support verrou de selle	<i>Haltebügel Sitzbankverschluss</i>	Estribo cerradura asiento
7	M02000031400	1	Dado serratura sella M22X1,5	<i>Nut seat closing M22X1.5</i>	Ecrou verrou de selle M22X1,5	<i>Mutter M22X1,5 Sitzbankverschluss</i>	Tuerca cierre asiento M22X1,5
8	M25700002400	1	Cavo ghigliottina serratura sella	<i>Seat lock cable</i>	Câble guillottine verrou de selle	<i>Schneidkabel Sitzbankverschluss</i>	Cable guillotina cerradura asiento
9	M25100001400	1	Gancio chiusura sella	<i>Seat lock snap</i>	Crochet de fermeture selle	<i>Haken Sitzbankverschluss</i>	Gancho cerradura asiento
10	M40700001011	2	Antivibrante serbatoio	<i>Tank damping pad</i>	Dispositif anti-vibratoire réservoir	<i>Schwingungsdämpfer Tank</i>	Antivibrante depósito
11	M17300004625	1	Cerniera serbatoio nera	<i>Black tank hinge</i>	Charnière réservoir noir	<i>Tankscharnier schwarz</i>	Charnela depósito negra
12	M2137351	6	Gommino sostegno serbatoio	<i>Tank support ring</i>	Caoutchouc de support du réservoir	<i>Gummiunterlage Tankhalterung</i>	Goma soporte depósito
13	C0000003	6	Fascetta per gommino serbatoio 200X4.8, nera	<i>Tank support ring black clamp 200X4.8</i>	Collier pour caoutchouc réservoir 200X4.8, noir	<i>Klemme für Gummi Tank 200X4.8, schwarz</i>	Abrazadera para goma depósito 200X4.8, negra
14	M02000016401	2	Dado M12X1,25	<i>Nut M12X1.25</i>	Ecrou M12X1,25	<i>Mutter M12X1,25</i>	Tuerca M12X1,25
15	M07000014102	2	Distanziale perno telaio motore	<i>Engine chassis pin spacer</i>	Entretoise axe cadre moteur	<i>Distanzscheibe Zapfen Rahmen Motor</i>	Distanciador perno chasis motor
16	M06000013401	1	Perno telaio motore, anteriore	<i>Front engine shaft</i>	Axe d'entraînement avant	<i>Vorne Zapfen Motorrahmen</i>	Perno del. motor

(*) Specificare colore - *Specify colour* - Spécifier le coloris - *Farbe angeben* - Especificar color

COLORI - COLOURS - COLORIS - FARBEN - COLORES			
N°	Cod.	Nero - <i>Black</i> - Noir - <i>Schwarz</i> - Negro	Rosso - <i>Red</i> - Rouge - <i>Rot</i> - Rojo
1	M2137011 - - -	213	651



GRANPASSO
1200

Telaio - Frame - Cadre - Rahmen - Chassis

001

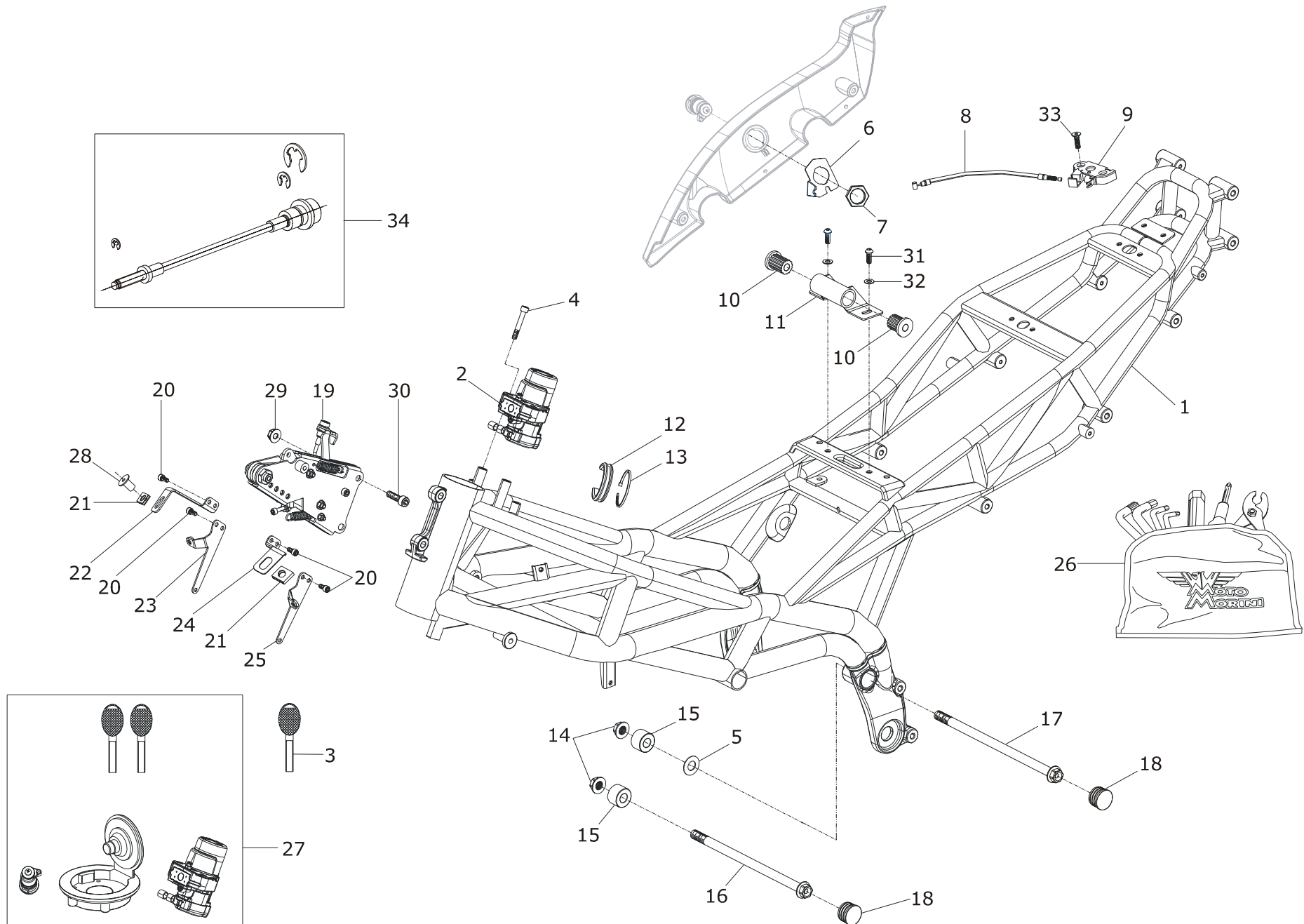

N°	Cod.	Q.	Descrizione	Description	Description	Beschreibung	Descripción
17	M06000012401	1	Perno telaio-motore, posteriore	Rear engine shaft	Axe d'entraînement arrière	Zapfen Motorrahmen hinten	Perno chasis-motor trasero
18	M1837011	4	Tappo chiusura fissaggio telaio	Chassis closing plug	Capuchon de fermeture fixation cadre	Verschlussstopfen Rahmenbefestigung	Tapón de cierre fijación chasis
19	M2137040	1	Anima telaietto anteriore	Front frame support	Ame sous-cadre avant	Kern Vorderrahmen	Alma del chasis delantero
20	M01000018401	4	Vite TCEI M5X8	Screw TCEI M5X8	Vis TCEI M5X8	Schraube TCEI M5X8	Tornillo TCEI M5X8
21	M2137171	2	Graffetta fissaggio musetto	Front fairing fixing bracket	Clip de fixation partie avant	Befestigungsklammer Frontverkleidung	Grapa de fijación carenado delantero
22	M2137121	1	Staffa dx supporto musetto	Front fairing support right bracket	Bride de support dt partie avant	Bügel re. Halterung Frontverkleidung	Brida der. soporte carenado delantero
23	M2137151	1	Staffa dx supporto scudo anteriore	Front shield support right bracket	Broide de support dt tablier avant	Bügel re. Halterung Vorderschild	Brida der. soporte escudo delantero
24	M2137131	1	Staffa sx supporto musetto	Front fairing support left bracket	Bride de support gche partie avant	Bügel li. Halterung Frontverkleidung	Brida izq. soporte carenado delantero
25	M2137141	1	Staffa sx supporto scudo anteriore	Front shield support left bracket	Bride de support gche tablier avant	Bügel li. Halterung Vorderschild	Brida izq. soporte escudo delantero
26	M2144130	1	Trousse attrezzi	Tool kit	Trousse outils	Werkzeugkasten	Estuche de herramientas
27	M30100001300	1	Kit chiavi completo	Complete kit of wrenches	Kit de clés complet	Schlüsselsatz komplett	Kit llaves completo
28	M0079003	2	Rivetto antivibrante M5 Ø 9.6X18	Anti-vibrating rivet M5 Ø 9.6X18	Rivet antivibratoire M5 Ø 9.6X18	Niete schwingungs-dämpfend M5 Ø 9.6X18	Remache antivibraciones M5 Ø 9.6X18
29	M02000030401	2	Dado M8 flangiato autobloccante	Self-locking flanged nut M8	Ecrou bridé M8 de sécurité	Selbstsperrende M8 Flanschmutter	Tuerca embridada M8 autoblocante
30	M01000032401	2	Vite M8X30	Screw M8X30	Vis M8X30	Schraube M8X30	Tornillo M8X30
31	M01000031401	2	Vite M6X10	Screw M6X10	Vis M6X10	Schraube M6X10	Tornillo M6X10
32	M03000012400	2	Rondella Ø 6X16X1.5	Washer Ø 6X16X1.5	Rondelle Ø 6X16X1.5	Unterlegscheibe Ø 6X16X1.5	Arandela Ø 6X16X1.5
33	M01000043401	2	Vite M6X20	Screw M6X20	Vis M6X20	Schraube M6X20	Tornillo M6X20
34	R2137010	1	Comando flessibile con anelli di fermo	Flexible control with lock rings	Commande flexible équipée de bagues d'arrêt	Seilzug mit Haltering	Mando flexible con anillos de retén

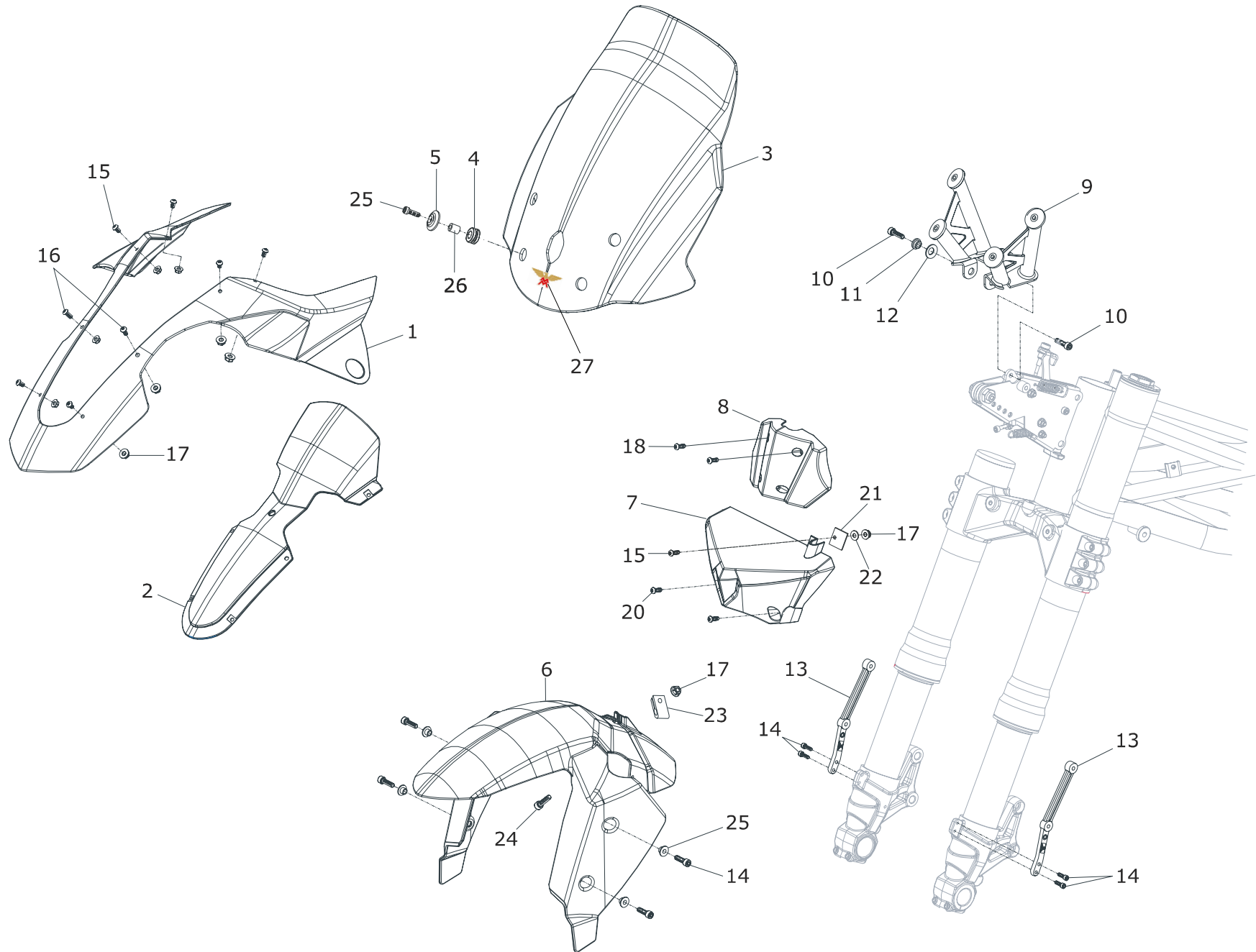

N°	Cod.	Q.	Descrizione	Description	Description	Beschreibung	Descripción	
1	M214207140	1	Contorno naso superiore	Upper edge	Pourtour nez supérieur	Umrandung Nase oben	Borde talón superior	
*	2	M2142081 - - -	1	Centrale naso superiore	Central edge	Élément central nez sup.	Mitte Nase oben	Central talón superior
3	M2142341	1	Parabrezza	Windproof	Pare-brise	Windschutzscheibe	Parabrís	
4	M40300004000	4	Silent-blok Ø12xØ25x10	Silent-block Ø12xØ25x10	Silentbloc Ø12xØ25x10	Silentblock Ø12xØ25x10	Silent-Block Ø12xØ25x10	
5	M2142931	4	Borchia Ø27xØ6,5x6	Bolt Ø27xØ6,5x6	Rivet Ø27xØ6,5x6	Beschlag Ø27xØ6,5x6	Remache Ø27xØ6,5x6	
*	6	M2142111 - - -	1	Parafango anteriore completo	Complete front mudguard	Garde-boue avant complet	Kotflügel vorne komplett	Guardabarros delantero completo
7	M214217140	1	Scudo forcella inferiore	Lower fork cover	Tablier fourche inférieure	Schild untere Gabel	Escudo horquilla inferior	
8	M214216140	1	Scudo forcella superiore	Upper fork cover	Tablier fourche supérieure	Schild obere Gabel	Escudo horquilla superior	
*	9	M2137031 - - -	1	Supporto parabrezza	Windproof support	Support pare-brise	Halterung Windschutzscheibe	Soporte parabris
10	M01000044401	2	Vite TCEI M6X16	Screw TCEI M6X16	Vis TCEI M6X16	Schraube TCEI M6X16	Tornillo TCEI M6X16	
11	M2137091	2	Perno	Spindle	Axe	Zapfen	Perno	
12	M0080004	2	Molla a tazza Ø 10.2X20X0.5	Belleville washer Ø 10.2X20X0.5	Rondelle belleville Ø 10.2X20X0.5	Spannscheibe Ø 10.2X20X0.5	Arandela elástica Ø 10.2X20X0.5	
13	M15500001102	2	Supporto parafango anteriore	Front mudguard support	Support pare-brise avant	Halterung Kotflügel vorne	Soporte guardabarros delantero	
14	M01000012401	4	Vite M5X16	Screw M5X16	Vis M5X16	Schraube M5X16	Tornillo M5X16	
15	M005204610	8	Vite TBEI M5X12	Screw TCEI M5X12	Vis TCEI M5X12	Schraube TCEI M5X12	Tornillo TCEI M5X12	
16	M01000049401	2	Vite M5X20	Screw M5X20	Vis M5X20	Schraube M5X20	Tornillo M5X20	
17	M02000008401	8	Dado M5 flangiato autobloccante	Self-locking flanged nut M5	Ecrou bridé M5 de sécurité	Selbstsperrende M5 Flanschmutter	Tuerca embridada M5 autoblocante	
18	M01000034401	2	Vite M5X10	Screw M5X10	Vis M5X10	Schraube M5X10	Tornillo M5X10	
20	M01000031401	2	Vite M6X10	Screw M6X10	Vis M6X10	Schraube M6X10	Tornillo M6X10	
21	M2142421	1	Piastrino passatubo freno superiore	Upper brake cable ring plate	Plaque passe-fil frein supérieur	Plättchen Schlauchführung Bremse vorne	Plaquita pasatubo freno delantero	
22	M03000012400	1	Rondella Ø 6X16X1.5	Washer Ø 6X16X1.5	Rondelle Ø 6X16X1.5	Unterlegscheibe Ø 6X16X1.5	Arandela Ø 6X16X1.5	
23	M40400007400	1	Passatubo freno posteriore	Rear brake cable ring	Passe-fil frein arrière	Schlauchführung Hinterradbremse	Pasatubo freno trasero	
24	M01000030401	1	Vite M5X22	Screw M5X22	Vis M5X22	Schraube M5X22	Tornillo M5X22	
25	M02200001400	4	Boccola per M5	Bushing x M5	Bague pour M5	Buchse für M5	Casquillo para M5	
26	M2142921	4	Distanziale Ø11,5xØ6.5x8,3	Spacer Ø11,5xØ6.5x8,3	Entretoise Ø11,5xØ6.5x8,3	Distanzscheibe Ø11,5xØ6.5x8,3	Distanciador Ø11,5xØ6.5x8,3	
27	M2242141	1	Adesivo	Adhesive	Adhésif	Decal	Adhesivo	

(*) Specificare colore - Specify colour - Spécifier le coloris - Farbe angeben - Especificar color

COLORI - COLOURS - COLORIS - FARBEN - COLORES					
N°	Cod.	Nero - Black - Noir Schwarz - Negro	Rosso - Red - Rouge Rot - Rojo	Bianco - White - Blanche Weiß - Blanc	Titanio - Titanium - Titanium Titanium - Titanium
2	M2142081 - -	-	41	207	61
6	M2142111 - -	-	41	207	61
9	M2137031 - -	213	651	-	-

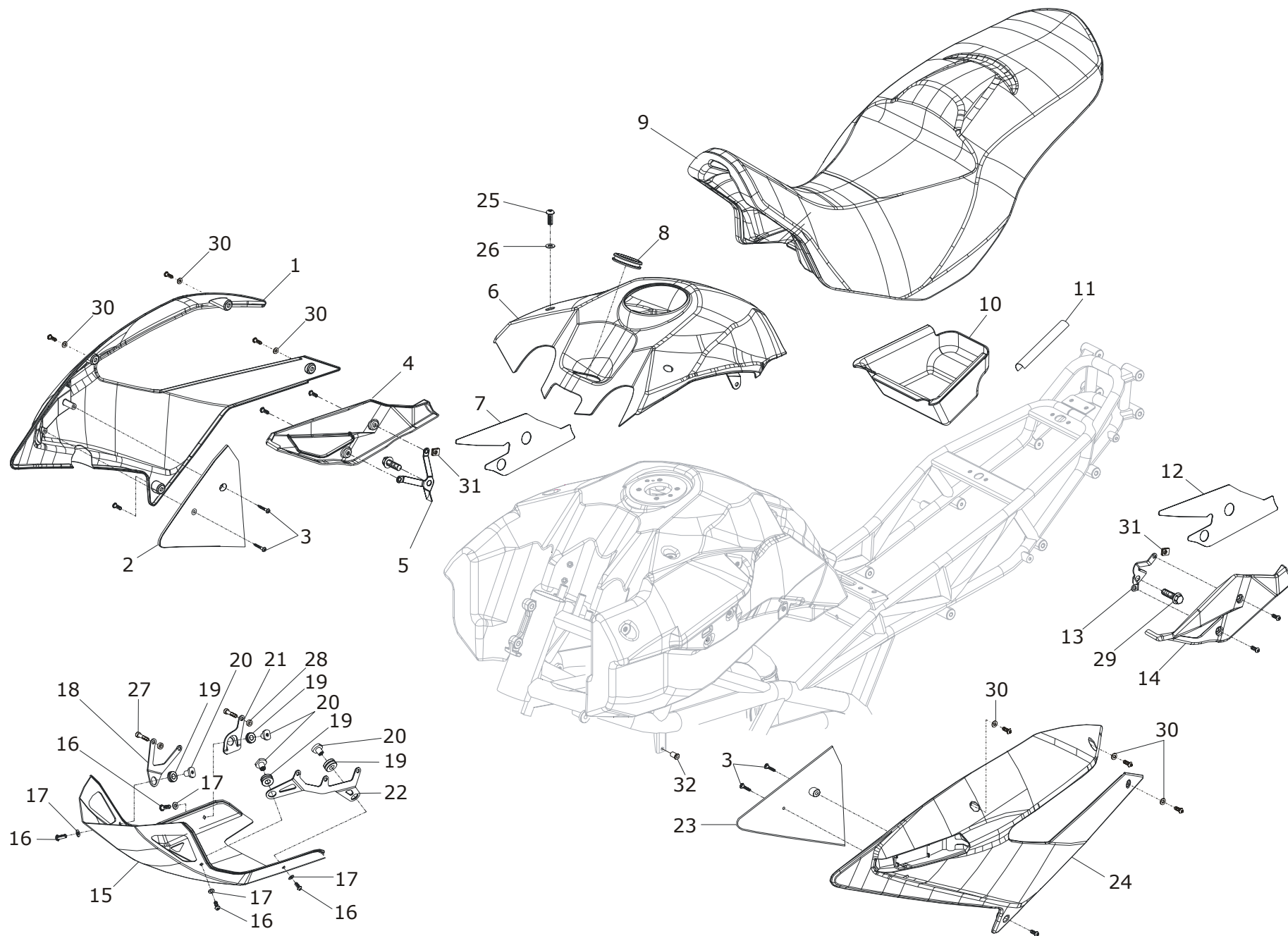

N°	Cod.	Q.	Descrizione	Description	Description	Beschreibung	Descripción	
*	1	M2142031	1	Cover serbatoio dx	<i>Tank right cover</i>	<i>Cache réservoir dt</i>	<i>Tankverkleidung re.</i>	Cubierta depósito der.
	2	M214266140	1	Setto interno cover dx	<i>Right cover inside wall</i>	<i>Cloison interne cache dt</i>	<i>Innenteil Verkleidung re.</i>	Interior cubierta der.
	3	M005202212	4	Vite TBEI M4X10	<i>Screw TBEI M4X10</i>	<i>Vis TBEI M4X10</i>	<i>Schraube TBEI M4X10</i>	Tornillo TBEI M4X10
	4	M214270140	1	Fianchetto laterale dx	<i>Right side fairings</i>	<i>Flanc dt</i>	<i>Seitenteil rechts</i>	Lateral der.
	5	M2142721	1	Staffa sostegno fianchetto dx	<i>Right side fairing supporting bracket</i>	<i>Etrier de support flanc dt</i>	<i>Stützbügel Seitenteil rechts</i>	Brida de soporte lateral der.
*	6	M2142011	1	Cover serbatoio superiore	<i>Upper tank cover</i>	<i>Cache réservoir supérieur</i>	<i>Tankverkleidung oben</i>	Cubierta depósito superior
	7	M2142771	1	Termoriflettente fianchetto dx	<i>Right side fairing heat shield</i>	<i>Termo-réfléchissant flanc dt</i>	<i>Thermoreflektor Seitenteil rechts</i>	Termorreflector lateral der.
	8	M2142651	1	Gommino contorno blocco chiave	<i>Key lock ring</i>	<i>Caoutchouc contour groupe clé</i>	<i>Zündschlossgummi</i>	Goma contacto de llave
	9	M2142351	1	Sella completa	<i>Complete seat</i>	<i>Selle complète</i>	<i>Sitzbank komplett</i>	Asiento completo
	10	M2142641	1	Vano portaoggetti	<i>Luggage compartment</i>	<i>Compartiment à objets</i>	<i>Handschuhfach</i>	Guantera
	11	M2142791	1	Nastro in velcro protezione sella	<i>Velcro seat protection</i>	<i>Ruban auto-agrippant protection selle</i>	<i>Velcro-Band Sitzbankschutz</i>	Cinta de velcro protección asiento
	12	M2142781	1	Termoriflettente fianchetto sx	<i>Left side fairing heat shield</i>	<i>Thermo-réfléchissant flanc gche</i>	<i>Thermoreflektor Seitenteil links</i>	Termorreflector lateral izq.
	13	M2142731	1	Staffa sostegno fianchetto sx	<i>Left side fairing support bracket</i>	<i>Bride de support flanc gche</i>	<i>Stützbügel Seitenteil links</i>	Brida de soporte lateral izq.
	14	M214271140	1	Fianchetto laterale sx	<i>Left side fairing</i>	<i>Flanc latéral gche</i>	<i>Seitenteil links</i>	Lateral izq.
	15	M2132121	1	Coppa protezione motore	<i>Engine protection cover</i>	<i>Couvercle de protection moteur</i>	<i>Motorschutzschale</i>	Tapa de protección motor
	16	M01000005401	4	Vite M6X16	<i>Screw M6X16</i>	<i>Vis M6X16</i>	<i>Schraube M6X16</i>	Tornillo M6X16
	17	M006303310	4	Rondella Ø 6.4X14X1.5 zincata bianca	<i>White galvanised washer Ø 6.4X14X1.5</i>	<i>Rondelle Ø 6.4X14X1.5 zinguée blanc</i>	<i>Unterlegscheibe Ø 6.4X14X1.5 verzinkt weiss</i>	Arandela Ø 6.4X14X1.5 galvanizado blanco
	18	M2142531 213	1	Supporto ant. dx paracoppa	<i>Cover front right support</i>	<i>Support avant dt protection moteur</i>	<i>Halterung vorne re. Wannenschutz</i>	Soporte delantero der. protección cárter
	19	M40300001400	4	Silent-blok 6X14X9	<i>Silent-block 6X14X9</i>	<i>Silentbloc 6X14X9</i>	<i>Silentblock 6X14X9</i>	Silent-Block 6X14X9
	20	M05000012104	2	Boccola silent-block filettata	<i>Silent-block threaded bushing</i>	<i>Bague silentbloc taraudée</i>	<i>Gewindebuchse Silentblock</i>	Casquillo silent-block enroscado

(*) Specificare colore - *Specify colour* - Spécifier le coloris - *Farbe angeben* - Especificar color

COLORI - COLOURS - COLORIS - FARBEN - COLORES				
N°	Cod.	Rosso - Red - Rouge Rot - Rojo	Bianco - White - Blanche Weiß - Blanc	Titanio - Titanium - Titanium Titanium - Titanium
1	M2142031 - -	41	207	61
6	M2142011 - -	41	207	61

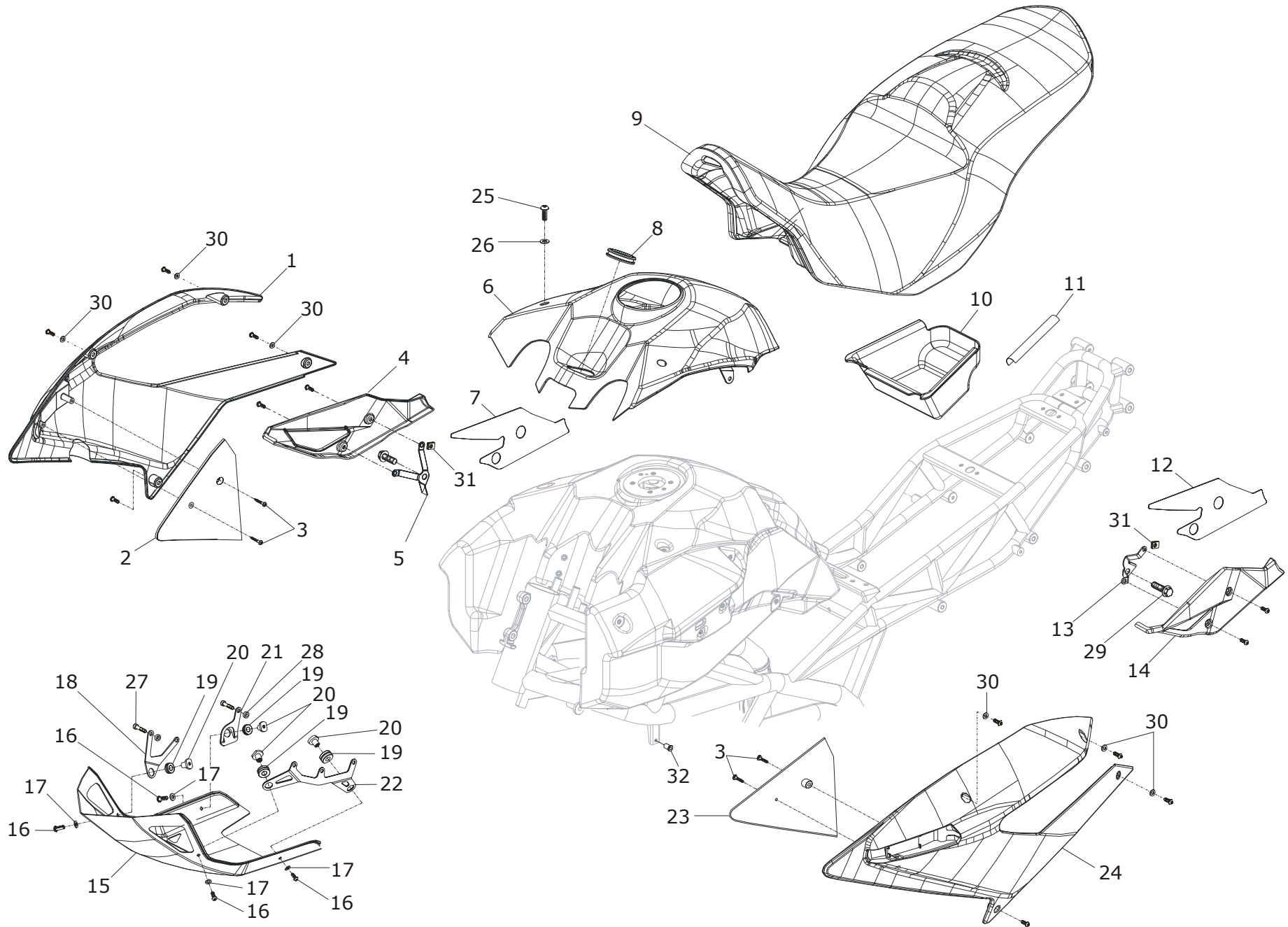

N°	Cod.	Q.	Descrizione	Description	Description	Beschreibung	Descripción
21	M2142521 213	1	Supporto posteriore destro paracoppa	Cover rear right support	Support arrière dt protection moteur	Halterung hinten re. Wannenschutz	Soporte trasero der. protección cárter
22	M2142541 213	1	Supporto sinistro paracoppa	Left cover support	Support gche protection moteur	Halterung li. Wannenschutz	Soporte izq. protección cárter
23	M214267140	1	Setto interno cover sx	Left cover inside wall	Cloison interne cache	Innenteil Verkleidung li.	Interior cubierta izq.
* 24	M2142051	1	Cover serbatoio sx	Tank left cover	Cache réservoir gche	Tankverkleidung li.	Cubierta depósito izq.
25	M01000034401	2	Vite M5X10	Screw M5X10	Vis M5X10	Schraube M5X10	Tornillo M5X10
26	M214285110	2	Rondella bisellata Ø 5	Chamfered washer Ø 5	Rondelle biseautée Ø 5	Schubunterlegscheibe Ø 5	Arandela biselada Ø 5
27	M97600022400	6	Vite TORK TCB M6X40	Screw TORK TCB M6X40	Vis TORK TCB M6X40	Schraube TORK TCB M6X40	Tornillo TORK TCB M6X40
28	M2343021	6	Distanziale per molla fermo cavo sonda Lambda	Stop spring spacer Lambda cable	Entretoise pour ressort serre-câble sonde Lambda	Distanzstück für Kabelklemmfeder Lambdasonde	Espesor para muelle sujeción cable sonda Lambda
29	M01000060401	2	Vite flangiata M10X12X1,25	Flanged screw M10X12X1.25	Vis-bride M10X12X1,25	Flanschschraube M10X12X1,25	Tornillo embridada M10X12X1,25
30	M0079005	6	Rondella bisellata Ø 5	Chamfered washer Ø 5	Rondelle biseautée Ø 5	Schubunterlegscheibe Ø 5	Arandela biselada Ø 5
31	M006218111	2	Clip M5	Clip M5	Clip M5	Clip M5	Clip M5
32	M0079005	1	Rivetto antivibrante M6	Anti-vibrating rivet M6	Rivet antivibratoire M6	Niete schwingungs-dämpfend M6	Remache antivibraciones M6

(*) Specificare colore - Specify colour - Spécifier le coloris - Farbe angeben - Especificar color

COLORI - COLOURS - COLORIS - FARBEN - COLORES				
N°	Cod.	Rosso - Red - Rouge Rot - Rojo	Bianco - White - Blanche Weiß - Blanc	Titanio - Titanium - Titanium Titanium - Titanium
24	M2142051 - -	41	207	61

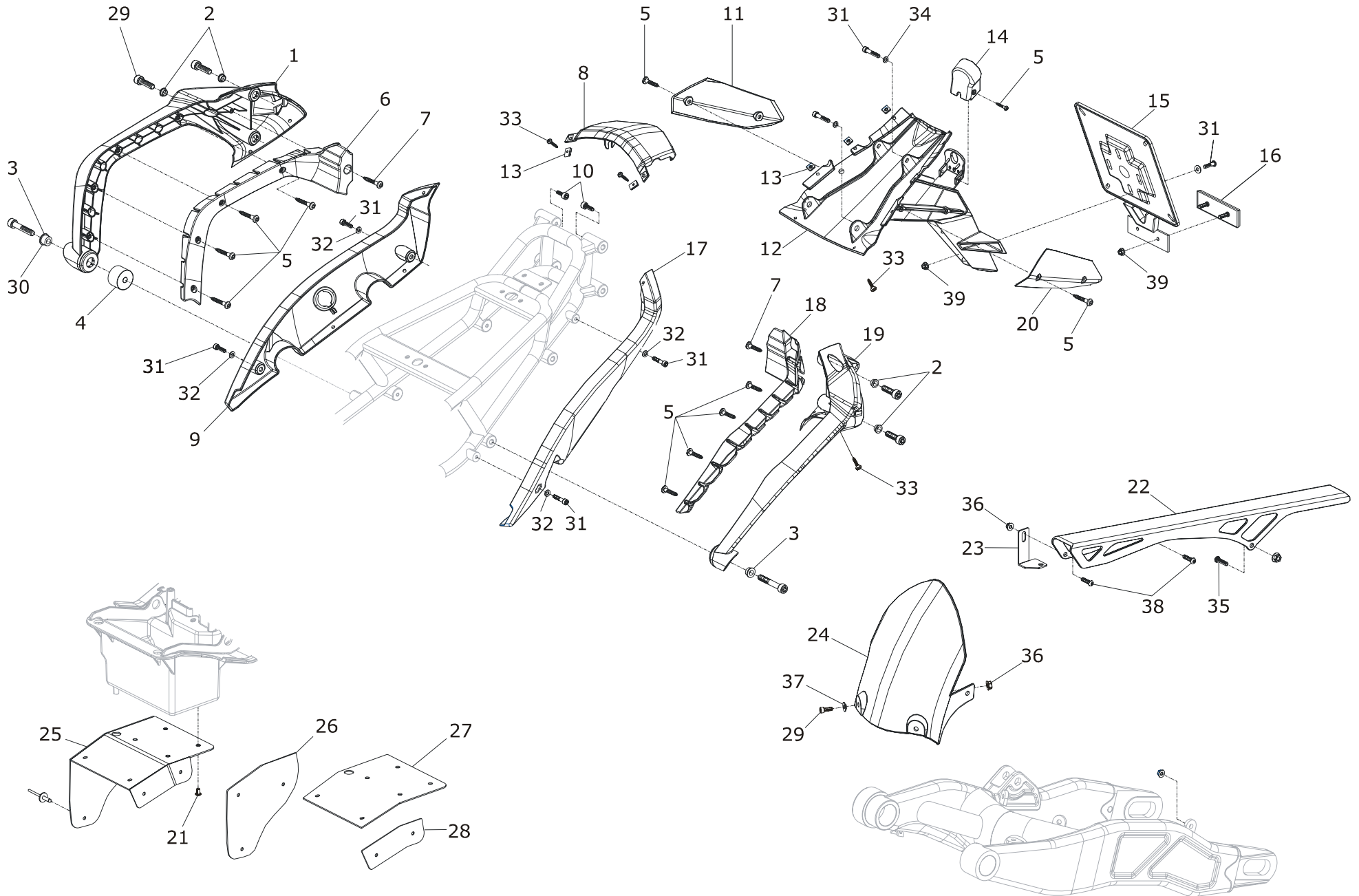

N°	Cod.	Q.	Descrizione	Description	Description	Beschreibung	Descripción	
*	1	M2142231	1	Maniglione destro	<i>Right handhold</i>	Manille dte	<i>Lenker re.</i>	Manillar der.
	2	M2142291	4	Boccola maniglione Ø 12	<i>Handhold bushing Ø 12</i>	Bague manille Ø 12	<i>Buchse Lenker Ø 12</i>	Casquillo manillar Ø 12
	3	M2142311	2	Boccola maniglione Ø 16	<i>Handhold bushing Ø 16</i>	Bague manille Ø 16	<i>Buchse Lenker Ø 16</i>	Casquillo manillar Ø 16
	4	M2142741	1	Distanziale maniglione destro	<i>Righ handhold spacer</i>	Entretoise manille dte	<i>Distanzialscheibe Lenker re.</i>	Distanciadore juntas Manillar der.
	5	M006010312	13	Vite autofilettante TB Ø 4.2X9.5	<i>Threaded screw TB Ø 4.2X9.5</i>	Vis autotaraudeuse TB Ø 4.2X9.5	<i>Selbstdrehende Schraube TB Ø 4.2X9.5</i>	Tornillo autoenroscante TB Ø 4.2X9.5
	6	M214224140	1	Inserto maniglione destro	<i>Right handhold insert</i>	Insert manille dte	<i>Innenteil Lenker re.</i>	Inserto manillar der.
	7	M01000074102	2	Vite autofilettante testa mezza tonda Ø 4.2X16	<i>Button head threaded screw Ø 4.2X16</i>	Vis autotaraudeuse culasse arrondie Ø 4.2X16	<i>Selbstdrehende Schraube halbrunder Kopf Ø 4.2X16</i>	Tornillo autoenroscante de cabeza semiredonda Ø 4.2X16
*	8	M2142201	1	Aletta posteriore	<i>Rear spoiler</i>	Ailette arrière	<i>Flügel hinten</i>	Aleta trasera
	9	M214219140	1	Fianco laterale posteriore destro	<i>Rear righ side fairing</i>	Flanc latéral arrière dt	<i>Seitenteil hinten re.</i>	Flanco lateral trasero der.
	10	M2137311	2	Vite perno aletta posteriore	<i>Rear spoiler pin screw</i>	Vis pivot ailette arrière	<i>Schraube Bolzen Flügel hinten</i>	Tornillo perno aleta trasera
	11	M214227140	1	Cover portatarga destro	<i>Number plate right cover</i>	Cache porte-plaque dt	<i>Verkleidung Kennzeichenhalterung re.</i>	Cubierta porta-matrícula der.
	12	M214225140	1	Portatarga centrale	<i>Central number plate holder</i>	Porte-plaque central	<i>Kennzeichenhalterung Mitte</i>	Porta-matrícula central
	13	M09700004100	2	Staffetta per autofilettante	<i>Bracket for threaded screw</i>	Bride pour vis autotaraudeuse	<i>Bügel für selbstdrehende Schraube</i>	Brida para autoenroscante
	14	M214228140	1	Coperchio luce targa	<i>Number plate light cover</i>	Cache éclairage plaque	<i>Deckel Kennzeichenlicht</i>	Cubierta luces de matrícula
	15	M24500001010	1	Portatarga	<i>Number plate holder</i>	Porte-plaque	<i>Kennzeichenhalterung</i>	Porta matrícula
	16	M31100001400	1	Catadiottro posteriore	<i>Rear cat's eye</i>	Catadioptrre arrière	<i>Rückstrahler hinten</i>	Reflector trasero
	17	M214218140	1	Fianco laterale posteriore sinistro	<i>Rear left side fairing</i>	Flanc latéral arrière gche	<i>Seitenteil hinten li.</i>	Flanco lateral trasero izq.
	18	M214222140	1	Inserto maniglione sx	<i>Handhloed left insert</i>	Insert manille gche	<i>Innenteil Lenker li.</i>	Inserto manillar izq.
*	19	M2142211	1	Maniglione sx	<i>Left handhold</i>	Manille gche	<i>Lenker li.</i>	Manillar izq.
	20	M214226140	1	Cover portatarga sinistro	<i>Number plate left cover</i>	Cache porte-plaque gche	<i>Verkleidung Kennzeichenhalterung li.</i>	Cubierta porta-matrícula izq.

(*) Specificare colore - Specify colour - Spécifier le coloris - Farbe angeben - Especificar color

COLORI - COLOURS - COLORIS - FARBEN - COLORES				
N°	Cod.	Rosso - Red - Rouge Rot - Rojo	Bianco - White - Blanche Weiß - Blanc	Titanio - Titanium - Titanium Titanium - Titanium
1	M2142231 - -	41	207	61
8	M2142201 - -	41	207	61
19	M2142211 - -	41	207	61

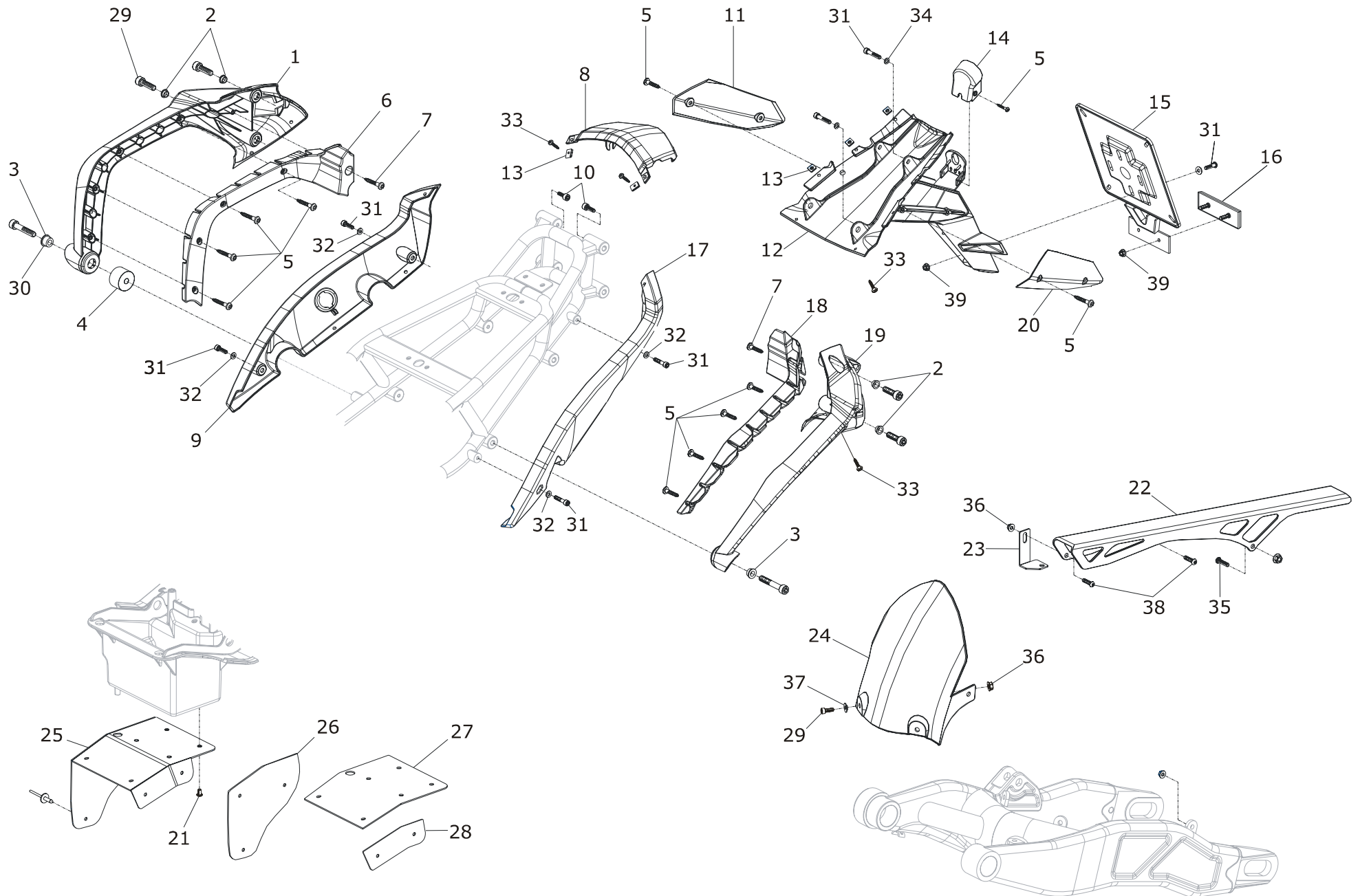



N°	Cod.	Q.	Descrizione	Description	Description	Beschreibung	Descripción
21	M01000034401	1	Vite M5X10	Screw M5X10	Vis M5X10	Schraube M5X10	Tornillo M5X10
22	M214233140	1	Paracatena	Chain guard	Carter de chaîne	Kettenschutz	Protección de cadena
23	M2338041	1	Staffa carter catena	Chain guard bracket	Bride carter de chaîne	Bügel Kettenkasten	Brida guardacadena
24	M214232140	1	Parafango posteriore	Rear mudguard	Garde-boue arrière	Schutzblech hinten	Guardabarros trasero
25	M2143241 63	1	Paracalore batteria	Battery heat guard	Pare-chaleur batterie	Hitzeschutz Batterie	Protección calor batería
26	M2143281	1	Termoriflettente dx paracalore batteria	Battery head guard right heat shield	Thermoréfléchissant dt. pare-chaleur batterie	Thermoreflektor Hitzeschutz Batterie	Termorreflector der. protección calor batería
27	M2143261	1	Termoriflettente centr. paracalore batteria	Battery head guard central heat shield	Thermoréfléchissant centr. pare-chaleur batterie	Thermoreflektor Mitte Hitzeschutz Batterie	Termorreflector central protección calor batería
28	M2143271	1	Termoriflettente sx paracalore batteria	Battery head guard left heat shield	Thermoréfléchissant gche pare-chaleur batterie	Thermoreflektor li. Hitzeschutz Batterie	Termorreflector izq. protección calor batería
29	M01000015401	6	Vite M8X25	Screw M8X25	Vis M8X25	Schraube M8X25	Tornillo M8X25
30	M005012810	2	Vite TCEI M8X45	Screw TCEI M8X45	Vis TCEI M8X45	Schraube TCEI M8X45	Tornillo TCEI M8X45
31	M01000012401	8	Vite M5X16	Screw M5X16	Vis M5X16	Schraube M5X16	Tornillo M5X16
32	M03000022110	4	Rondella Ø 5.5X10X1.5 per antivibrante strumentazione	Washer Ø 5.5X10X1.5 anti-vibration instrumentation	Rondelle Ø 5.5X10X1.5 pour antivibratoire instruments de bord	Unterlegscheibe Ø 5.5X10X1.5 für Schwingungsdämpfer vibrationsdämpfend	Arandela Ø 5.5X10X1.5 para antivibraciones instrumentos
33	M006005412	12	Vite autofilettante TB Ø 3.5X13	Threaded screw TB Ø 3.5X13	Vis autotaraudeuse TB Ø 3.5X13	Selbstdrehende Schraube TB Ø 3.5X13	Tornillo autoenroscante TB Ø 3.5X13
34	M03000013400	4	Rondella Ø 5X15	Washer Ø 5X15	Rondelle Ø 5X15	Unterlegscheibe Ø 5X15	Arandela Ø 5X15
35	M01000035401	1	Vite M5X16	Screw M5X16	Vis M5X16	Schraube M5X16	Tornillo M5X16
36	M02000008401	5	Dado M5 flangiato autobloccante	Self-locking flanged nut M5	Ecrou-bride M5 de sécurité	Selbstsperrende M5 Flanschmutter	Tuerca embridada M5 autoblocante
37	M02200001400	2	Boccola per M5	Bushing for M5	Bague pour M5	Buchse für M5	Casquillo para M5
38	M005204610	2	Vite TBEI M5X12	Screw TBEI M5X12	Vis TBEI M5X12	Schraube TBEI M5X12	Tornillo TBEI M5X12
39	M02000008401	4	Dado M5 flangiato	Flanged nut M5	Ecrou-bride M5	Flanschmutter M5	Tuerca embridada M5

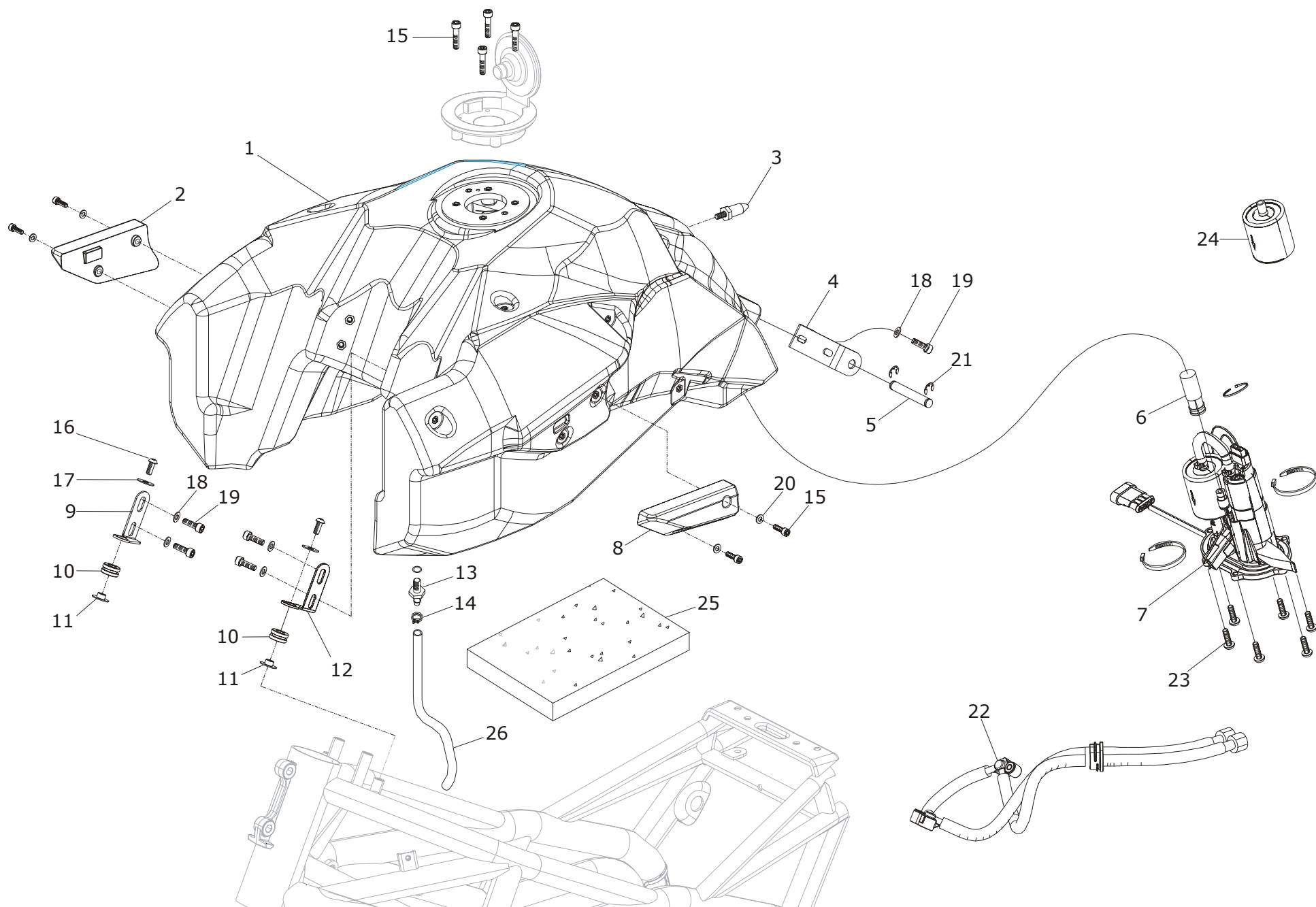

N°	Cod.	Q.	Descrizione	Description	Description	Beschreibung	Descripción
1	M2134010 218	1	Serbatoio carburante	<i>Fuel tank</i>	Réservoir à carburant	<i>Benzintank</i>	Depósito combustible
2	M2142371	1	Slider serbatoio dx	<i>Tank right slider</i>	Slider réservoir dt	<i>Slider Tank re.</i>	Slider depósito der.
3	M2142691	1	Spina fissaggio sella	<i>Seat fixing pin</i>	Goupille de verrouillage selle	<i>Befestigungsstift Sitzbank</i>	Espiga de fijación asiento
4	M17300003105	1	Piastra supporto serbatoio	<i>Tank support plate</i>	Plaque de support du réservoir	<i>Halteplatte Tank</i>	Placa de soporte depósito
5	M06000022113	1	Perno serbatoio	<i>Tank spindle</i>	Pivot réservoir	<i>Tankzapfen</i>	Perno depósito
6	M2134071	1	Protezione sensore riserva	<i>Reserve sensor guard</i>	Protection capteur de réserve	<i>Schutz Benzinreservesensor</i>	Protección sensor reserva
7	M81000001300	1	Pompa carburante	<i>Fuel pump</i>	Pompe à essence	<i>Benzinpumpe</i>	Bomba gasolina
8	M2142361	1	Slider serbatoio sx	<i>Tank left slider</i>	Slider réservoir gche	<i>Slider Tank li.</i>	Slider depósito der.
9	M2134061	1	Staffa serbatoio telaio dx	<i>Right tank bracket</i>	Bride réservoir dt	<i>Tankbügel Rahmen rechts</i>	Estribo depósito chasis der.
10	M40300001400	2	Silent-block 6X14X9	<i>Silent-block 6X14X9</i>	Silentbloc 6X14X9	<i>Silentblock 6X14X9</i>	Silent-Block 6X14X9
11	M02200009400	2	Boccola silent-block	<i>Silent-block bushing</i>	Bague silentbloc	<i>Buchse Silentblock</i>	Casquillo silent-block
12	M2134051	1	Staffa serbatoio telaio sx	<i>Left tank bracket</i>	Bride réservoir gche	<i>Tankbügel links</i>	Estribo depósito chasis izq.
13	M01000018400	2	Sfiati filettati	<i>Threaded breather</i>	Events taraudés	<i>Entlüfter mit Gewinde</i>	Venteo enroscado
14	M03600014400	3	Fascetta a filo	<i>Hose clamp</i>	Bague de serrage fil	<i>Drahtschelle</i>	Abrazadera de hilo
15	M01000012401	8	Vite M5X16	<i>Screw M5X16</i>	Vis M5X16	<i>Schraube M5X16</i>	Tornillo M5X16
16	M01000030401	2	Vite M5X22	<i>Screw M5X22</i>	Vis M5X22	<i>Schraube M5X22</i>	Tornillo M5X22
17	M03000013400	2	Rondella Ø 5X15	<i>Washer Ø 5X15</i>	Rondelle Ø 5X15	<i>Unterlegscheibe Ø 5X15</i>	Arandela Ø 5X15
18	M03000012400	4	Rondella Ø 6X16X1.5	<i>Washer Ø 6X16X1.5</i>	Rondelle Ø 6X16X1.5	<i>Unterlegscheibe Ø 6X16X1.5</i>	Arandela Ø 6X16X1.5
19	M01000044401	6	Vite TCEI M6X16	<i>Screw TCEI M6X16</i>	Vis TCEI M6X16	<i>Schraube TCEI M6X16</i>	Tornillo TCEI M6X16
20	M214285110	4	Rondella bisellata Ø 5	<i>Chamfered washer Ø 5</i>	Rondelle biseautée Ø 5	<i>Schubunterlegscheibe Ø 5</i>	Arandela biselada Ø 5
21	M04000005400	2	Anello elastico radiale 9 UNI 7434	<i>Radial elastic ring 9 UNI 7434</i>	Bague élastique radiale 9 UNI 7434	<i>Radialer Federring 9 UNI 7434</i>	Anillo elástico radial 9 UNI 7434
22	M51100002300	1	Tubazione benzina completa	<i>Complete fuel piping system</i>	Tuyauterie essence complète	<i>Benzinschlauch komplett</i>	Tubuladura de gasolina completa
23	M01000035401	6	Vite M5X16	<i>Screw M5X16</i>	Vis M5X16	<i>Schraube M5X16</i>	Tornillo M5X16
24	M81000002400	1	Filtro pompa benzina	<i>Fuel pump flange</i>	Filtre pompe à essence	<i>Filter Benzinpumpe</i>	Filtro bomba gasolina
25	M40500003400	1	Protezione adesiva	<i>Protection adhesive</i>	Adhésif de protection	<i>Schutzklebestreifen</i>	Adhesivo de protección
26	M51000012400	1	Tubo Ø 6,5X10,5	<i>Pipe Ø 6,5X10,5</i>	Tube Ø 6,5X10,5	<i>Schlauch Ø 6,5X10,5</i>	Tubo Ø 6,5X10,5

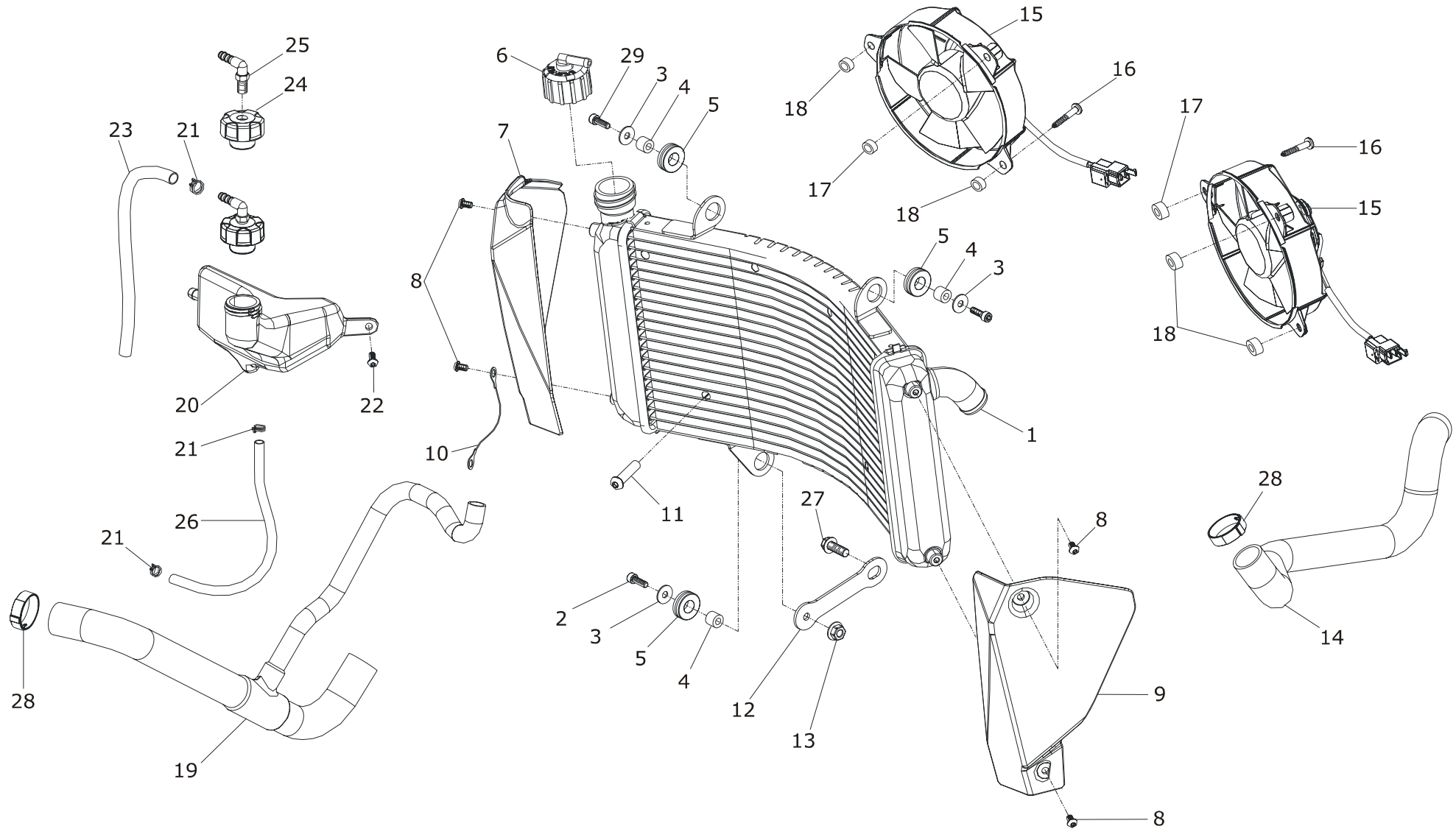

N°	Cod.	Q.	Descrizione	Description	Description	Beschreibung	Descripción
1	M75100002300	1	Radiatore	Radiator	Radiateur	Kühler	Radiador
2	M01000013401	2	Vite M6X20	Screw M6X20	Vis M6X20	Schraube M6X20	Tornillo M6X20
3	M03000012400	3	Rondella Ø 6X16X1.5	Washer Ø 6X16X1.5	Rondelle Ø 6X16X1.5	Unterlegscheibe 6X16X1.5	Arandela 6X16X1.5
4	M91000001400	3	Bussola fissaggio radiatore olio	Oil cooler fastening bush	Douille fixation radiateur huile	Büchse Befestigung Ölkühler	Casquillo fijación radiador aceite
5	M40300002400	3	Silent-block radiatore	Radiator silent block	Silentbloc radiateur	Silentblock Kühler	Silent-Block radiador
6	M75400001400	1	Tappo radiatore	Radiator plug	Capuchon de radiateur	Kühlerdeckel	Tapón radiador
7	M214231140	1	Cover radiatore laterale dx	Radiator right side cover	Cache radiateur latéral dt	Abdeckung Kühler rechte Seite	Cubierta radiador lateral der.
8	M01000034401	4	Vite M5X10	Screw M5X10	Vis M5X10	Schraube M5X10	Tornillo M5X10
9	M214230140	1	Cover radiatore laterale sx	Radiator left side cover	Cache radiateur latéral gche	Abdeckung Kühler linke Seite	Cubierta radiador lateral izq.
10	M35100014600	1	Cavo massa radiatore	Radiator ground cable	Câble de masse radiateur	Negativkabel Kühler	Cable masa radiador
11	M02200006400	1	Boccola filettata per ventola	Fan threaded bushing	Bague taraudée pour ventilateur	Gewindebuchse für Lüfter	Casquillo enroscado para ventilador
12	M213504140	1	Bielletta supporto radiatore	Radiator support connecting rod	Bielle support radiateur	Pleuelstange Halterung Kühler	Biela soporte radiador
13	M02000010401	1	Dado M6 flangiato autobloccante	Self-locking flanged M6 nut	Ecrou M6 bridé de sécurité	Selbstsperrende Flanschmutter M6	Tuerca embridada M6 autobloccante
14	M97300009400	1	Tubo circuito acqua	Water system hose	Tube circuit d'eau	Wasserkreislaufschlauch	Tubo circuito agua
15	M75200001400	2	Ventola	Fan	Ventilateur	Klappe	Ventilador
16	M01000042403	6	Vite fissaggio ventola	Screw fastening fan	Vis fixation ventilateur	Schraube Befestigung Lüfter	Tornillo fijación ventilador
17	M02200003400	2	Boccola per ventola	Fan bushing	Bague pour ventilateur	Buchse für Lüfter	Casquillo para ventilador
18	M02200002400	4	Boccola per ventola	Fan bushing	Bague pour ventilateur	Buchse für Lüfter	Casquillo para ventilador
19	M97300008400	1	Tubo circuito acqua dx	Right water system hose	Tube circuit d'eau dt	Wasserkreislaufschlauch rechts	Tubo circuito agua der.
20	M75000003000	1	Vaso di espansione	Expansion reservoir	Vase d'expansion	Ausdehnungsgefäß	Vaso expansión
21	M03600004400	3	Anello stringitubo	Hose clamp	Bague serre-tube	Schlauchklemmring	Anillo de apriete tubo
22	M01000035401	1	Vite M5X16	Screw M5X16	Vis M5X16	Schraube M5X16	Tornillo M5X16
23	M2135061	1	Tubo Ø 6,5X10,5X600	Pipe 6.5X10.5X600	Tube Ø 6,5X10,5X600	Draht Ø 6,5X10,5X600	Tubo Ø 6,5X10,5X600
24	P2135011	1	Tappo vaso espansione	Expansion reservoir plug	Capuchon vase d'expansion	Stopfen Ausdehnungsgefäß	Tapón vaso de expansión
25	M0081003	1	Raccordo a resca 90° Ø 6 - G 1/8	Quick coupler joint 90° Ø 6 - G 1/8	Raccord 90° Ø 6 - G 1/8	Anschluss 90° Ø 6 - G 1/8	Racor 90° Ø 6 - G 1/8
26	M51000012400	1	Tubo 6,5X10,5	Pipe 6.5X10.5	Tube 6,5X10,5	Schlauch 6,5X10,5	Tubo 6,5X10,5
27	M01000060401	1	Vite TE flangiata M10X12X1,25	Flanged hexagonal screw M10X12X1.25	Vis-bride TE M10X12X1,25	Flanschschraube TE M10X12X1,25	Tornillo embridada TE M10X12X1,25
28	M03600002400	2	Fascetta CLIC R 96-300	CLIC clamp R 96-300	Collier CLIC R 96-300	Klemme CLIC R 96-300	Abrazadera CLIC R 96-300
29	M01000010005	2	Vite TCEI M6X25	Screw TCEI M6X25	Vis TCEI M6X25	Schraube TCEI M6X25	Tornillo TCEI M6X25

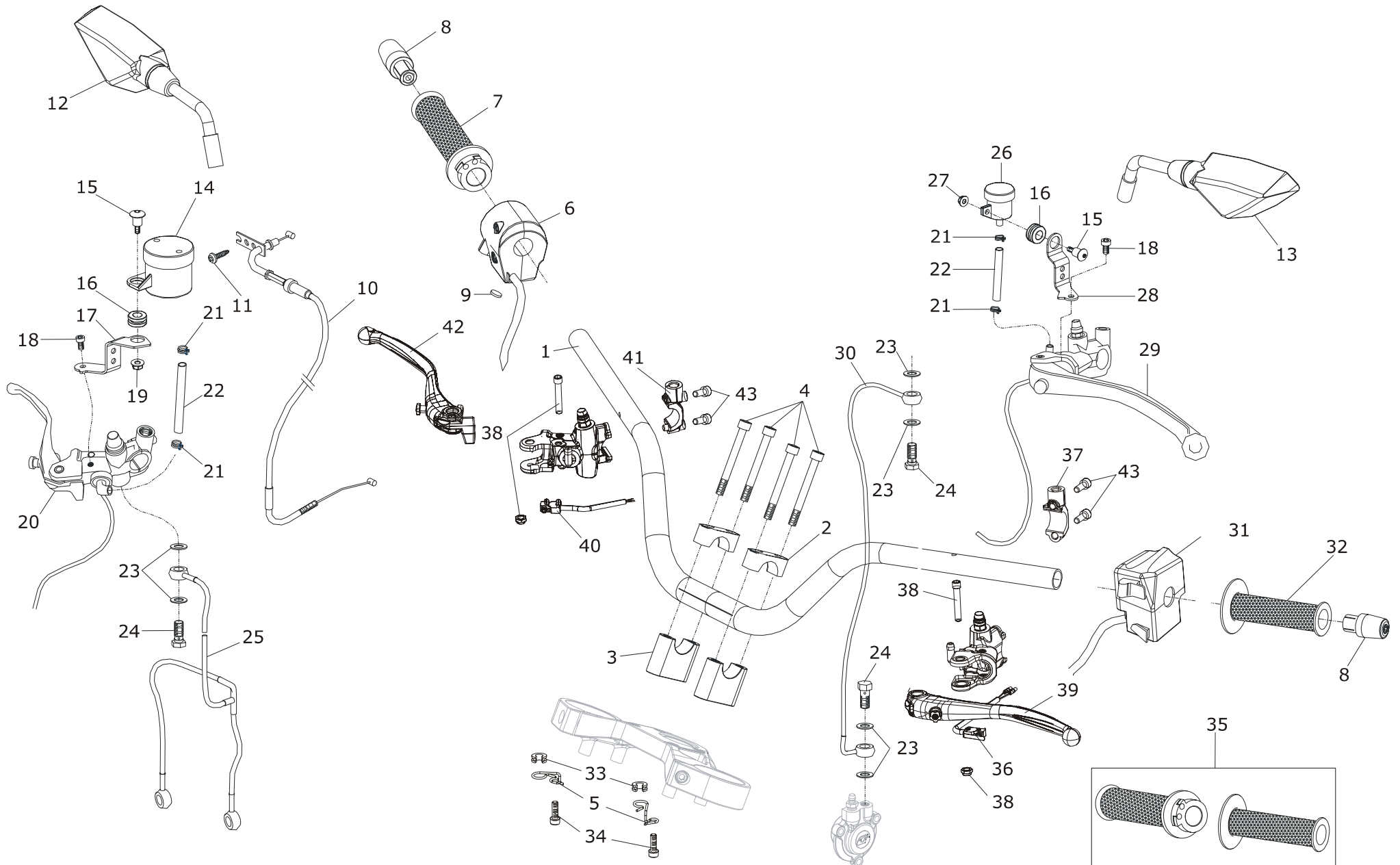

N°	Cod.	Q.	Descrizione	Description	Description	Beschreibung	Descripción
1	M2141201 59	1	Manubrio	<i>Handlebar</i>	Guidon	<i>Lenker</i>	Manillar
2	M17600001102	2	Cavallotto	<i>Jumper</i>	Béquille	<i>Bügel</i>	Brida
3	M17500001102	2	Riser	<i>Riser</i>	Riser	<i>Riser</i>	Riser
4	M01000039401	4	Vite TCEI M8X80	<i>Screw TCEI M8X80</i>	Vis TCEI M8X80	<i>Schraube TCEI M8X80</i>	Tornillo TCEI M8X80
5	M2141221	2	Passatubo freno - acceleratore	<i>Throttle brake cable ring</i>	Passe-tube frein-accélérateur	<i>Schlauchführung Bremse-Gasgriff</i>	Pasatubo freno - acelerador
6	M2143031	1	Commutatore dx	<i>Right switch</i>	Commutateur dt	<i>Wechselschalter re.</i>	Conmutador der.
7	M2141061	1	Manopola dx	<i>Right handgrip</i>	Manille dte	<i>Drehgriff re.</i>	Puño de gas der.
8	M2141231	1	Coppia contrappesi	<i>Pair of balancing weights</i>	Jeu de 2 contre-poids	<i>Paar Gegengewichte</i>	Par contrapesos
9	M2143141	1	Tappo foro commutatore dx	<i>Right switch desmodromic hole plug</i>	Capuchon orifice commutateur dt	<i>Verschlussstopfen Wechselschalter re.</i>	Tapón conmutador der.
10	M2141051	1	Cavo gas completo	<i>Complete throttle cable</i>	Câble des gaz complet	<i>Gaszug komplett</i>	Cable gas completo
11	M006023412	1	Vite autofilettante	<i>Threaded screw</i>	Vis autotaraudeuse	<i>Selbstdrehende Schraube</i>	Tornillo autoenroscante
12	M2142501	1	Specchietto retrovisore dx	<i>Right rearview mirror</i>	Rétroviseur dt	<i>Rückspiegel rechts</i>	Espejo retrovisor der.
13	M2142511	1	Specchietto retrovisore sx	<i>Left rearview mirror</i>	Rétroviseur gche	<i>Rückspiegel links</i>	Espejo retrovisor izq.
14	M2140031	1	Serbatoio olio freno	<i>Brake oil filler cap</i>	Réservoir huile de frein	<i>Tankdeckel Bremsöl</i>	Depósito de aceite freno
15	M2131021	1	Vite fissaggio serbatoio olio	<i>Oil tank fixing screw</i>	Vis de fixation réservoir à huile	<i>Befestigungsschraube Ölbehälter</i>	Tornillo de fijación depósito de aceite
16	M0079001	1	Gommino supporto serbatoio olio	<i>Oil tank holder ring</i>	Caoutchouc de support réservoir à huile	<i>Gummi Halterung Öltank</i>	Goma soporte depósito de aceite
17	M2140041	1	Staffa supporto serbatoio olio	<i>Oil tank support bracket</i>	Bride de support du réservoir à huile	<i>Haltebügel Ölbehälter</i>	Brida de soporte depósito de aceite
18	M005028112	1	Vite supporto serbatoio olio M6X10	<i>Oil tank holder screw M6X10</i>	Vis de support du réservoir à huile M6X10	<i>Befestigungsschraube Ölbehälter M6X10</i>	Tornillo de fijación depósito de aceite M6X10
19	M0062001	1	Dado flangiato autofrenante M5	<i>Flanged self-locking nut M5</i>	Ecrou bridé autofreinant M5	<i>Flanschmutter selbstbremsend</i>	Tuerca embridada autofrenante
20	M2140021	1	Pompa freno anteriore radiale	<i>Front radial brake pump</i>	Pompe frein avant radial	<i>Radialpumpe Vorderbremse</i>	Bomba radial de freno delantero
21	M007800112	2	Clip stringitubo nera	<i>Black hose clamp</i>	Clip serre-tube, noir	<i>Schlauchklemme schwarz</i>	Clip de apriete tubo negro
22	M0081001	2	Tube	<i>Pipe</i>	Tube	<i>Schlauch</i>	Tube
23	M0063001	4	Rondella rame Ø 10X14X1.5	<i>Copper washer Ø 10X14X1.5</i>	Rondelle en cuivre Ø 10X14X1.5	<i>Kupferunterlegscheibe Ø 10X14X1.5</i>	Arandela de cobre Ø 10X14X1.5
24	M0061001	3	Vite forata M10X1	<i>Drilled screw M10X1</i>	Vis percée M10X1	<i>Lochschraube M10X1</i>	Tornillo perforado M10X1

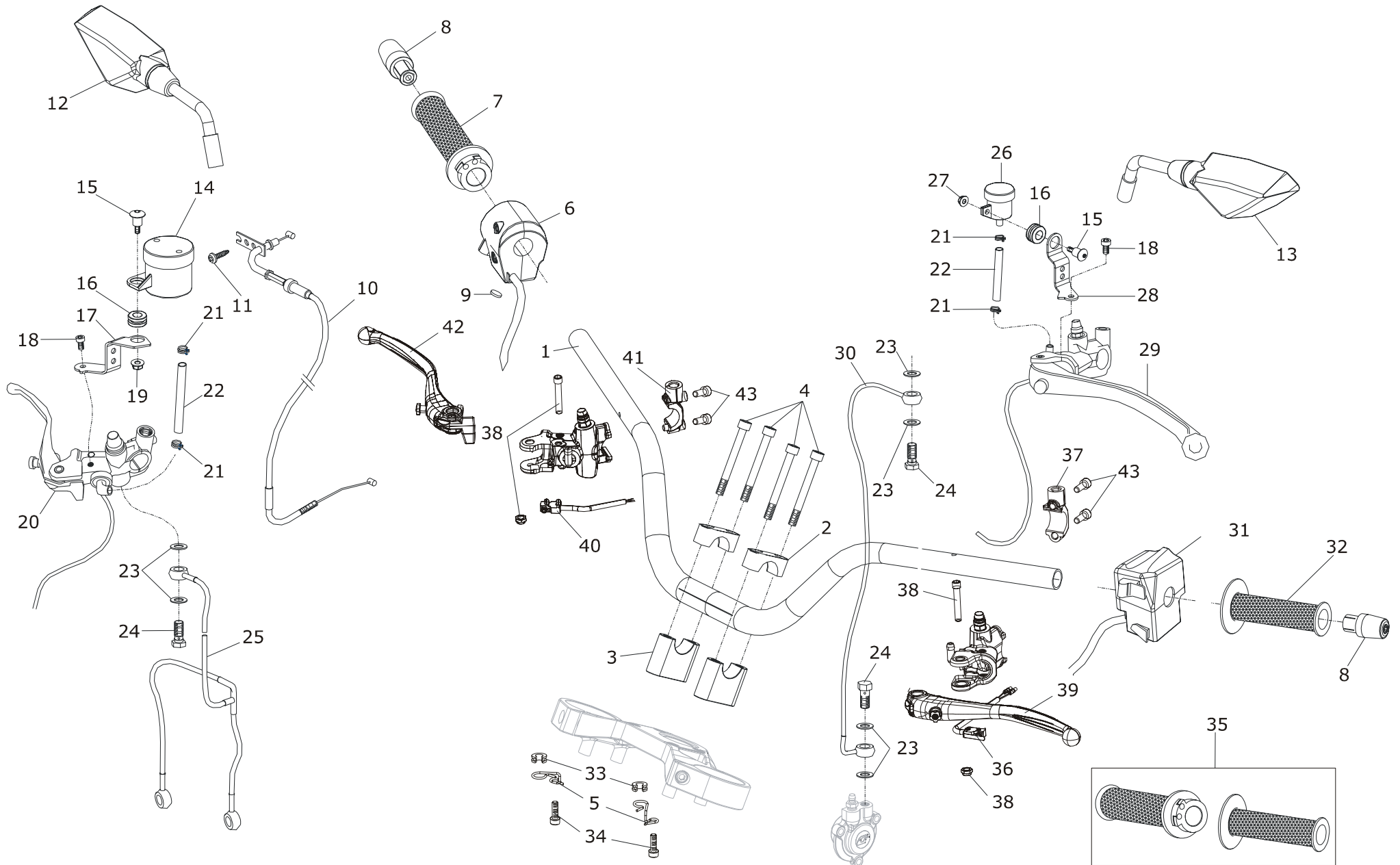

N°	Cod.	Q.	Descrizione	Description	Description	Beschreibung	Descripción
25	M2140051	1	Tubo olio freno	<i>Oil brake screw</i>	Tube huile de frein	<i>Bremsölschlauch</i>	Tubo aceite de freno
26	M0081002	1	Serbatoio olio frizione	<i>Clutch oil tank</i>	Réservoir huile d'embrayage	<i>Kupplungsölbehälter</i>	Depósito de aceite de embrague
27	M02000008401	1	Dado M5 flangiato autobloccante	<i>Flanged nut M5 self-locking</i>	Ecrou M5 bridé de sécurité	<i>Selbstsperrende M5 Flanschmutter</i>	Tuerca embridada M5 autoblocante
28	M2131041	1	Staffa supporto serbatoio olio frizione	<i>Clutch oil tank holder bracket</i>	Bride de support du réservoir huile d'embrayage	<i>Halteflansch Kupplungsölbehälter</i>	Brida de soporte depósito de aceite de embrague
29	M13300005300	1	Impianto frizione pompa radiale	<i>Radial pump clutch system</i>	Installation d'embrayage pompe radiale	<i>Kupplungssystem Radialpumpe</i>	Instalación de embrague bomba radial
30	M2131061	1	Tubo olio frizione	<i>Clutch oil hose</i>	Tube huile d'embrayage	<i>Kupplungsölschlauch</i>	Tubo aceite de embrague
31	M2143021	1	Commutatore sx	<i>Left switch</i>	Commutateur gche	<i>Wechselschalter li.</i>	Conmutador izq.
32	M2141241	1	Manopola sx	<i>Left handgrip</i>	Manille gche	<i>Drehgriff li.</i>	Puño de gas izq.
33	M02300009000	2	Boccola passatubo	<i>Bushing cable ring</i>	Bague passe-fil	<i>Gewindebuchse Schlauchführung</i>	Casquillo pasatubo
34	M01000054401	2	Vite TE M6X12	<i>Screw TE M6X12</i>	Vis TE M6X12	<i>Schraube TE M6X12</i>	Tornillo TE M6X12
35	S2141010	1	Coppia manopole	<i>Pair handgrips</i>	Jeu de 2 manilles	<i>Paar Drehgriffen</i>	Par puños de gas
36	R2131011	1	Micro switch pompa frizione	<i>Clutch pump micro switch</i>	Micro switch pompe friction	<i>Micro switch Kupplungspumpe</i>	Micro switch bomba embrague
37	R2131021	1	Cavallotto pompa radiale	<i>Radial pump jumper</i>	Béquille pompe radiale	<i>Bügel Radialpumpe</i>	Brida bomba radial
38	R2131031	2	Perno leva	<i>Brake lever</i>	Pivot levier	<i>Hebelzapfen</i>	Perno palanca
39	R2131041	1	Leva frizione	<i>Lever clutch</i>	Levier friction	<i>Hebel Kupplungs</i>	Palanca embrague
40	R2140011	1	Micro switch pompa freno	<i>Radial brake micro switch</i>	Micro switch pompe frein	<i>Micro switch Bremspumpe</i>	Micro switch bomba radial de freno
41	R2140021	1	Cavallotto pompa freno	<i>Jumper brake lever</i>	Béquille pompe frein	<i>Bügel Bremspumpe</i>	Brida bomba radial de freno
42	R2140031	1	Leva freno	<i>Brake lever</i>	Levier frein	<i>Bremspumpenhebel</i>	Palanca de freno
43	M005010112	4	Vite M6X25 TCEI zincata nera	<i>Black galvanised screw TECI M6X25</i>	Vis M6X25 TCEI zinguée noire	<i>Schraube M6X25 TCEI verzinkt schwarz</i>	Tornillo M6X25 TCEI galvanizada negra



GRANPASSO
1200

**Impianto elettrico - Electrical devices - Installation électrique -
Elektrik - Instalación eléctrica**

006a

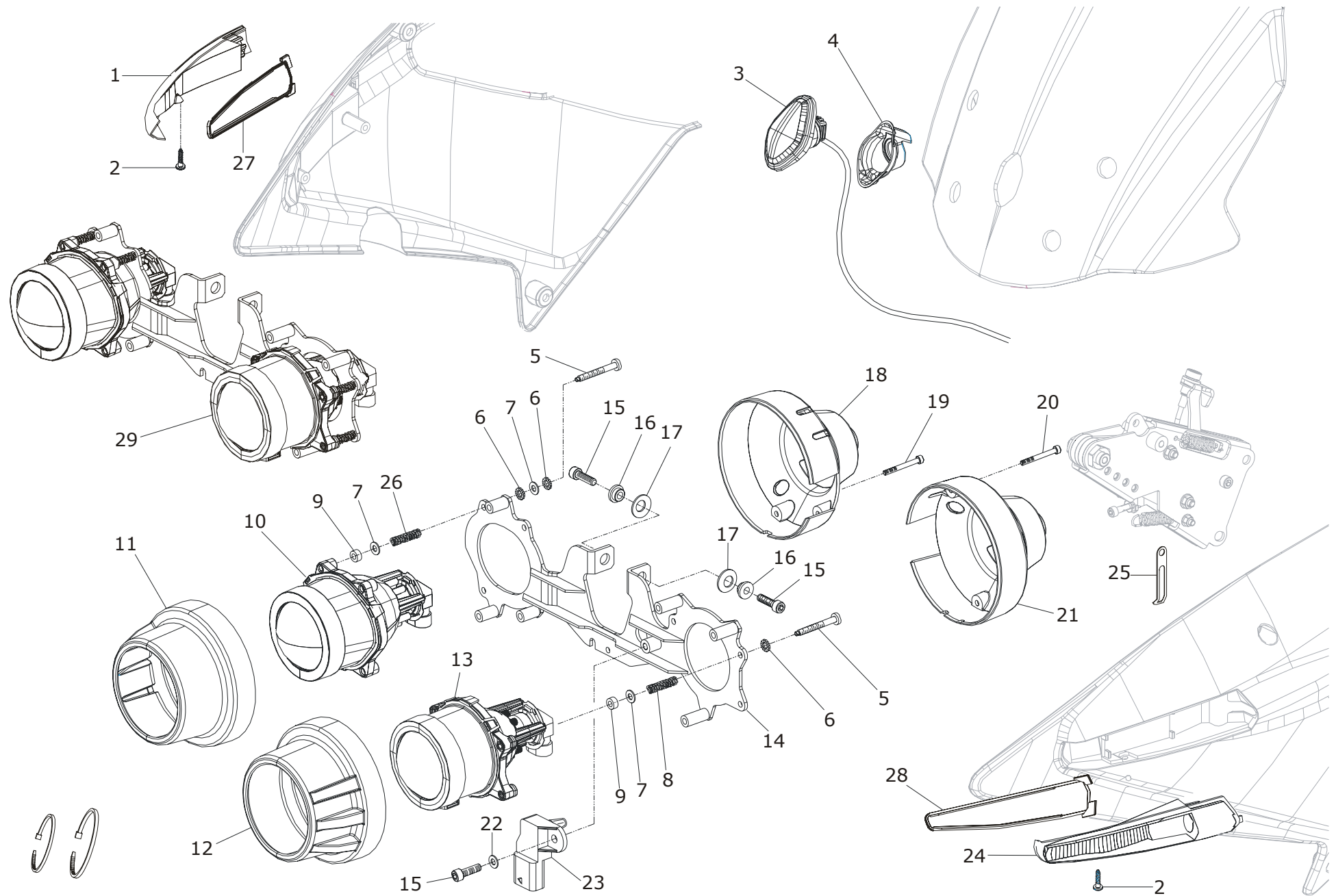

N°	Cod.	Q.	Descrizione	Description	Description	Beschreibung	Descripción
1	M32000003300	1	Indicatore di direzione dx	<i>Right direction indicator</i>	Indicateur de direction droit	<i>Richtungsanzeiger rechts</i>	Indicador de dirección der.
2	M006000312	2	Vite autofilettante Ø 2.2X9.5	<i>Threaded screw Ø 2.2X9.5</i>	Vis autotaraudeuse Ø 2.2X9.5	<i>Selbstdrehende Schraube Ø 2.2X9.5</i>	Tornillo autoenroscante Ø 2.2X9.5
3	M2143201	1	Luce di posizione	<i>Parking light</i>	Feu de position	<i>Standlicht</i>	Luz de posición
4	M2143151	1	Cuffia portalampada luce di posizione	<i>Parking light bulb holder cover</i>	Coiffe porte-lampe feu de position	<i>Lampenfassung Standlicht</i>	Portalámpara luz de posición
5	M006023512	6	Vite autofilettante TBIC M5X45	<i>Threaded screw TBIC M5X45</i>	Vis autotaraudeuse TBIC M5X45	<i>Selbstdrehende Schraube TBIC M5X45</i>	Tornillo autoenroscante TBIC M5X45
6	M006400210	9	Rondella dentellata Ø 5,5X10	<i>Crown washer Ø 5.5X10</i>	Rondelle dentée Ø 5,5X10	<i>Gezahnte Unterlegscheibe Ø 5,5X10</i>	Arandela dentada Ø 5,5X10
7	M03000022110	9	Rondella Ø 5.5X10X1.5	<i>Washer Ø 5.5X10X1.5</i>	Rondelle Ø 5.5X10X1.5	<i>Unterlegscheibe Ø 5.5X10X1.5</i>	Arandela Ø 5.5X10X1.5
8	M0080006	3	Molla Ø 6,5X9X30	<i>Spring Ø 6.5X9X30</i>	Ressort Ø 6,5X9X30	<i>Feder Ø 6,5X9X30</i>	Muelle Ø 6,5X9X30
9	M0079006	6	Gommino molla faro	<i>Beam spring ring</i>	Caoutchouc ressort frein	<i>Gummi Feder Scheinwerfer</i>	<i>Goma muelle faro</i>
10	M31000007400	1	Faro anabbagliante	<i>Low beam</i>	Feu de croisement	<i>Abblendlicht</i>	Luces de cruce
11	M214211140	1	Coperchio anteriore faro anabbagliante	<i>Low beam front cover</i>	Cache feu de croisement avant	<i>Deckel vorne Abblendlicht</i>	Tapa delantera luces de cruce
12	M214209140	1	Coperchio anteriore faro abbagliante	<i>High beam front cover</i>	Cache feu de route avant	<i>Deckel vorne Fernlicht</i>	Tapa delantera luces de carretera
13	M31000008400	1	Faro abbagliante	<i>High beam</i>	Feu de route	<i>Fernlicht</i>	Luces de carretera
14	M2137021	1	Piastra supporto fari	<i>Beam supporting plate</i>	Plaque de support des feux	<i>Halteplatte Lichter</i>	Placa de soporte luces
15	M01000044401	3	Vite TCEI M6X16	<i>Screw TCEI M6X16</i>	Vis TCEI M6X16	<i>Schraube TCEI M6X16</i>	Tornillo TCEI M6X16
16	M2137091	2	Perno	<i>Spindle</i>	Pivot	<i>Zapfen</i>	Perno
17	M0080004	2	Molla a tazza Ø 10.2X20X0.5	<i>Belleville washer Ø 10.2X20X0.5</i>	Rondelle Belleville Ø 10.2X20X0.5	<i>Spannscheibe Ø 10.2X20X0.5</i>	Arandela elástica Ø 10.2X20X0.5
18	M214212140	1	Coperchio posteriore faro anabbagliante	<i>Low beam rear cover</i>	Couvercle phare code arrière	<i>Deckel hinten Abblendlicht</i>	Tapa trasera luces de cruce
19	M005005410	3	Vite TCEI M4X30	<i>Screw TCEI M4X30</i>	Vis TCEI M4X30	<i>Schraube TCEI M4X30</i>	Tornillo TCEI M4X30
20	M005005510	3	Vite TCEI M4X35	<i>Screw TCEI M4X35</i>	Vis TCEI M4X35	<i>Schraube TCEI M4X35</i>	Tornillo TCEI M4X35
21	M214210140	1	Coperchio posteriore faro abbagliante	<i>High beam rear cover</i>	Cache phare de route avant	<i>Deckel hinten Fernlicht</i>	Tapa trasera luces de carretera
22	M03000020400	1	Rondella Ø 6X12X1	<i>Washer Ø 6X12X1</i>	Rondelle Ø 6X12X1	<i>Unterlegscheibe Ø 6X12X1</i>	Arandela Ø 6X12X1
23	M30000003400	1	Sensore TPRT	<i>Sensor TPRT</i>	Capteur TPRT	<i>Sensor TPRT</i>	Sensor TPRT
24	M32000004300	1	Indicatore di direzione sx	<i>Left direction indicator</i>	Indicateur de direction gch	<i>Richtungsanzeiger link</i>	Indicador de dirección izq.
25	M0219001	1	Fascetta plastificata	<i>Plastified hose clamp</i>	Collier plastifié	<i>Klemme aus Kunststoff</i>	Abrazadera plastificata
26	M0080008	3	Molla Ø 6.3X9X20	<i>Spring Ø 6.3X9X20</i>	Ressort Ø 6.3X9X20	<i>Feder Ø 6.3X9X20</i>	Muelle Ø 6.3X9X20
27	M2143371	2	Guarnizione indicatore di direzione dx	<i>Gasket right direction indicator</i>	Garniture indicateur de direction droit	<i>Dichtung Richtungsanzeiger rechts</i>	Junta indicador de dirección der.
28	M2143381	2	Guarnizione indicatore di direzione sx	<i>Gasket left direction indicator</i>	Garniture indicateur de direction gch	<i>Dichtung Richtungsanzeiger link</i>	Junta indicador de dirección izq.
29	R2143051	1	Kit faro anteriore	<i>Headlight kit</i>	Kit phare avant	<i>Scheinwerfer-Set</i>	Kit de faro delantero



GRANPASSO
1200

**Impianto elettrico - Electrical devices - Installation électrique -
Elektrik - Instalación eléctrica**

006b

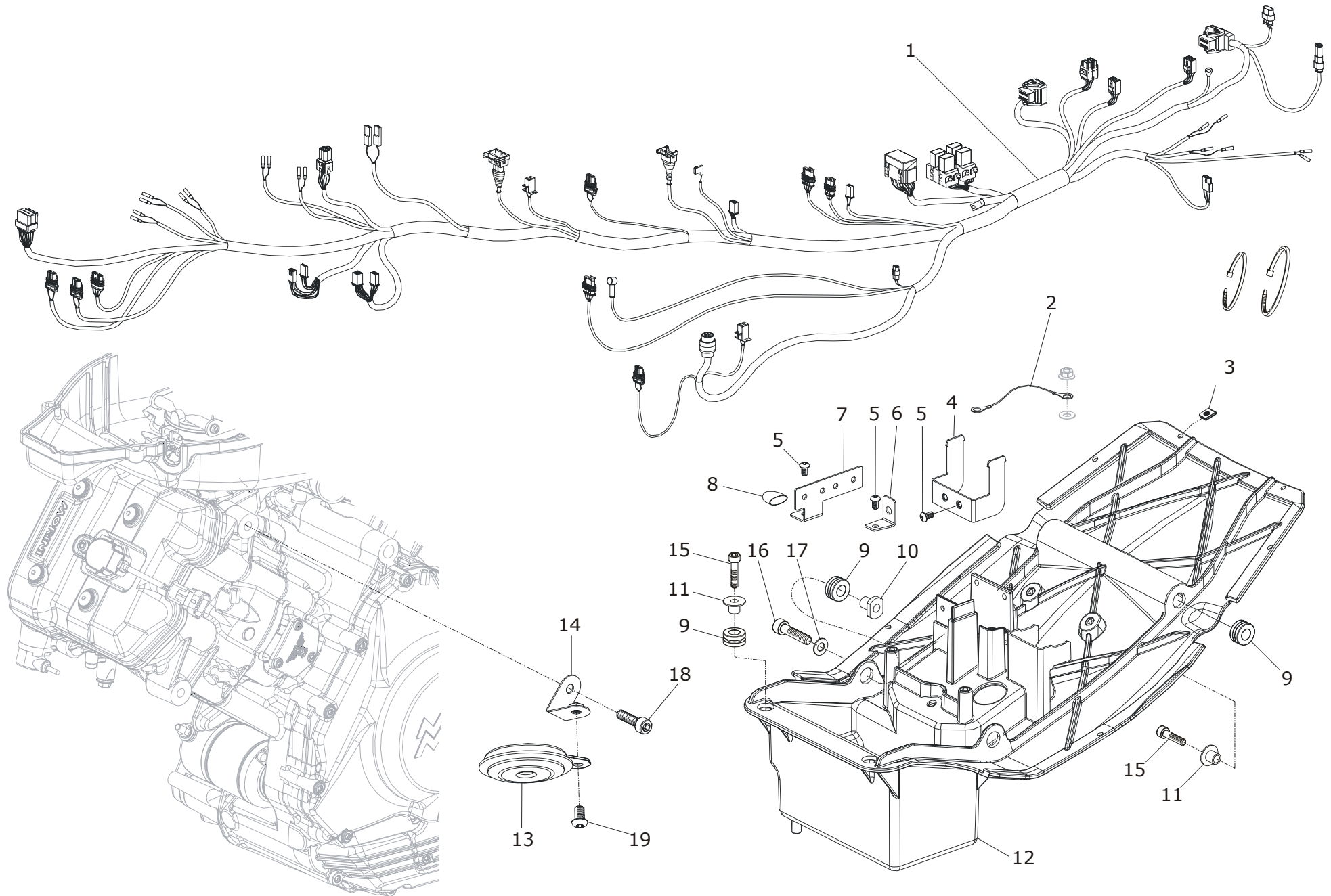

N°	Cod.	Q.	Descrizione	Description	Description	Beschreibung	Descripción
1	M2143011	1	Cablaggio principale	Main wiring	Câblage principal	Hauptverkabelung	Cableado principal
2	M2143161	1	Cablaggio massa regolatore	Regulator ground cable	Câblage masse régulateur	Masseverkabelung Regler	Cableado masa regulador
3	M09700004100	4	Staffetta per autofilettante	Bracket for threaded screw	Bride pour vis autotaraudeuse	Bügel für selbstdrehende Schraube	Brida para autoenroscante
4	M2143101	1	Staffa supporto fusibiliera	Fuse box bracket	Bride de support boîte à fusibles	Bügel Halterung Sicherungskasten	Brida soporte caja de fusibles
5	M01000034401	3	Vite M5X10	Screw M5X10	Vis M5X10	Schraube M5X10	Tornillo M5X10
6	M2143111	1	Staffa supporto fusibili	Fuse brackets	Bride de support fusibles	Haltebügel Sicherungen	Brida soporte fusibles
7	M2143131	1	Staffa supporto relais	Exhaust muffler relais	Bride de support relais	Haltebügel Relais	Brida soporte relé
8	M2143251	1	Cappuccio protezione cavo relais	Relay cable protection cup	Capuchon de protection câble relais	Schutzkappe Relaiskabel	Capuchón de protección cable relé
9	M40300001400	2	Silent-block 6X14X9	Silent-block 6X14X9	Silentbloc 6X14X9	Silentblock 6X14X9	Silent-Block 6X14X9
10	M05000012104	2	Boccola silent-block filettata	Bushing Silent-block threaded bushing	Bague taraudée silentbloc	Gewindebuchse Silentblock	Casquillo silent-block enroscado
11	M02200009400	2	Boccola silent-block	Silent-block bushing	Bague silentbloc	Buchse Silentblock	Casquillo silent-block
12	M21500003002	1	Vano tecnico	Technical compartment	Compartment technique	Technisches Fach	Alojamiento técnico
13	M33000001400	1	Avvisatore acustico	Warning horn	Avertisseur sonore	Akustische Warnanzeige	Avisador acústico
14	M17800003102	1	Staffa avvisatore acustico	Horn bracket	Bride avertisseur sonore	Bügel akustische Warnanzeige	Brida avisador acústico
15	M01000030401	8	Vite M5X22	Screw M5X22	Vis M5X22	Schraube M5X22	Tornillo M5X22
16	M01000072104	2	Vite M6X55	Screw M6X55	Vis M6X55	Schraube M6X55	Tornillo M6X55
17	M03000020400	2	Rondella Ø 6X12X1	Washer Ø 6X12X1	Rondelle Ø 6X12X1	Unterlegscheibe Ø 6X12X1	Arandela Ø 6X12X1
18	M01000060401	1	Vite TE flangiata M10X12X1,25	Flanged screw TE M10X12X1.25	Vis-bride TE M10X12X1,25	Flanschschraube TE M10X12X1,25	Tornillo embridada TE M10X12X1,25
19	M01000038401	1	Vite M8X12	Screw M8X12	Vis M8X12	Schraube M8X12	Tornillo M8X12

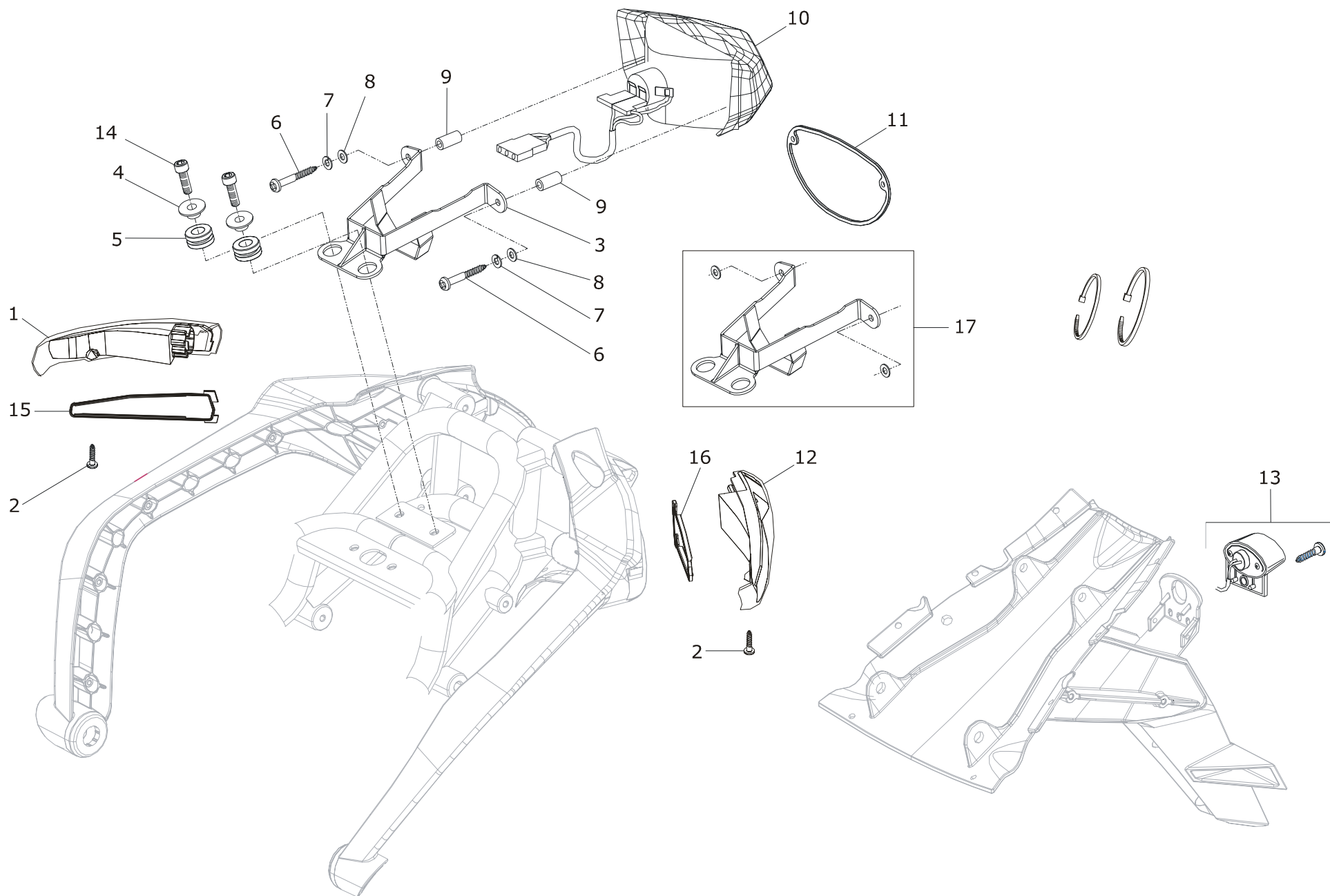

N°	Cod.	Q.	Descrizione	Description	Description	Beschreibung	Descripción
1	M32000003300	1	Indicatore di direzione dx	<i>Right direction indicator</i>	Indicateur de direction droit	<i>Richtungsanzeiger recht</i>	Indicador de dirección der.
2	M006023612	2	Vite autofilettante	<i>Threaded screw</i>	Vis autotaraudeuse	<i>Selbstdrehende Schraube</i>	Tornillo autoenroscante
3	M2142601	1	Supporto fanalino posteriore nero	<i>Tail light black support</i>	Support feu arrière, noir	<i>Halterung Rückleuchte schwarz</i>	Soporte faro trasero negro
4	M02200009400	2	Boccola silent-block	<i>Silent-block bushing</i>	Bague Silentbloc	<i>Buchse Silentblock</i>	Casquillo Silent-block
5	M40300001400	2	Silent-block 6X14X9	<i>Silent-block 6X14X9</i>	Silentbloc 6X14X9	<i>Silentblock 6X14X9</i>	Silent-Block 6X14X9
6	M006011110	2	Vite autofilettante Ø 4.2X45	<i>Threaded screw Ø 4.2X45</i>	Vis autotaraudeuse Ø 4.2X45	<i>Selbstdrehende Schraube Ø 4.2X45</i>	Tornillo autoenroscante Ø 4.2X45
7	M03000009400	2	Rosetta elastica spaccata Ø 5	<i>Open elastic washer Ø 5</i>	Rondelle élastique fendue Ø 5	<i>Federscheibe Ø 5</i>	Arandela elástica rajada Ø 5
8	M03000022110	2	Rondella Ø 5.5X10X1.5	<i>Washer Ø 5.5X10X1.5</i>	Rondelle Ø 5.5X10X1.5	<i>Unterlegscheibe Ø 5.5X10X1.5</i>	Arandela Ø 5.5X10X1.5
9	M2142681	2	Distanziale fanalino posteriore	<i>Tail light spacer</i>	Entretoise feu arrière	<i>Distanzscheibe Rückleuchte</i>	Distanciator faro trasero
10	M31000009400	1	Fanalino posteriore	<i>Tail light</i>	Appareil d'éclairage arr.	<i>Rückleuchte</i>	Faro trasero
11	M2143211	1	Guarnizione per fanalino posteriore	<i>Tail light gasket</i>	Joint pour feu arrière	<i>Dichtung Rückleuchte</i>	Junta faro trasero
12	M32000004300	1	Indicatore di direzione sx	<i>Left direction indicator</i>	Indicateur de direction gch	<i>Richtungsanzeiger link</i>	Indicador de dirección izq.
13	M31000003400	1	Luce targa	<i>Number plate light</i>	Eclairage de la plaque d'immatriculation	<i>Kennzeichenbeleuchtung</i>	Luz matrícula
14	M01000013401	2	Vite M6X20	<i>Screw M6X20</i>	Vis M6X20	<i>Schraube M6X20</i>	Tornillo M6X20
15	M2143371	2	Guarnizione indicatore di direzione dx	<i>Gasket right direction indicator</i>	Garniture indicateur de direction droit	<i>Dichtung Richtungsanzeiger rechts</i>	Junta indicador de dirección der.
16	M2143381	2	Guarnizione indicatore di direzione sx	<i>Gasket left direction indicator</i>	Garniture indicateur de direction gch	<i>Dichtung Richtungsanzeiger link</i>	Junta indicador de dirección izq.
17	R2142010	1	Kit supporto fanalino posteriore, stampato nero	<i>Kit tail light black support</i>	Kit support feu arrière, noir	<i>Halterung Rückleuchte schwarz kit</i>	Kit soporte faro trasero negro



GRANPASSO
1200

**Dispositivi elettronici - Electronic parts - Dispositifs électroniques -
Elektronik - Dispositivos electrónicos**

007

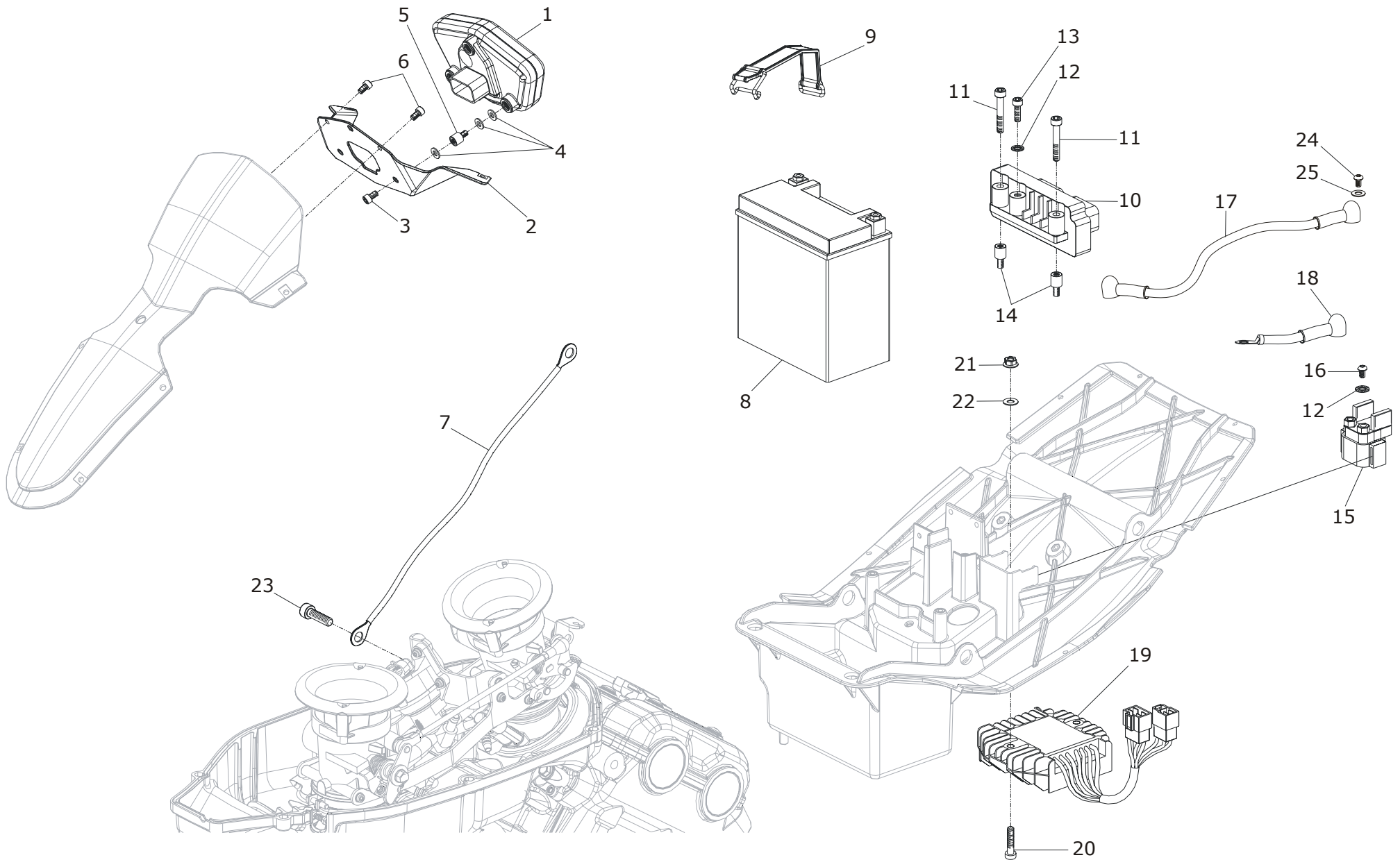

N°	Cod.	Q.	Descrizione	Description	Description	Beschreibung	Descripción
1	M30600003000	1	Strumentazione	<i>Instrumentation</i>	Instruments de bord	<i>Instrumenten</i>	Instrumentos
2	M2142151	1	Supporto strumentazione	<i>Instrumentation support</i>	Support instruments de bord	<i>Instrumentenhalterung</i>	Soporte instrumentos
3	M01000025401	3	Vite TCBEI M5X8	<i>Screw TCBEI M5X8</i>	Vis TCBEI M5X8	<i>Schraube TCBEI M5X8</i>	Tornillo TCBEI M5X8
4	M006302610	9	Rondella Ø 5.3X15X1.5	<i>Washer Ø 5.3X15X1.5</i>	Rondelle Ø 5.3X15X1.5	<i>Unterlegscheibe Ø 5.3X15X1.5</i>	Arandela Ø 5.3X15X1.5
5	M07500003000	3	Antivibrante strumentazione	<i>Instrumentation damping pads</i>	Dispositif antivibratoire instruments de bord	<i>Schwingungsdämpfer Instrumente</i>	Antivibrante instrumentos
6	M01000018401	2	Vite DIN912 TCEI M5X8	<i>Screw DIN912 TCEI M5X8</i>	Vis DIN912 TCEI M5X8	<i>Schraube DIN912 TCEI M5X8</i>	Tornillo DIN912 TCEI M5X8
7	M35100010600	1	Cavo da neg. batteria a massa motore	<i>Cable form neg pole to engine ground cable</i>	Câble de nég. à masse moteur	<i>Kabel von Neg. Batterie bis Masse Motor</i>	Cable de neg. batería a masa motor
8	M38500004400	1	Batteria	<i>Battery</i>	Batterie	<i>Batterie</i>	Batería
9	M40500006000	1	Maniglia solleva batteria	<i>Battery lifting lever</i>	Poignée de levage batterie	<i>Hebegriff Batterie</i>	Asas batería
10	M30500001510	1	Centralina elettronica	<i>Electronic Control Unit</i>	Unité de contrôle	<i>Elektronische Steuerung</i>	Centralita electrónica
11	M01000026401	2	Vite M5X30	<i>Screw M5X30</i>	Vis M5X30	<i>Schraube M5X30</i>	Tornillo M5X30
12	M03000023104	2	Rondella dentellata Ø 6	<i>Crown washer Ø 6</i>	Rondelle dentée Ø 6	<i>Gezahnte Unterlegscheibe Ø 6</i>	Arandela dentada Ø 6
13	M01000044401	1	Vite TCEI M6X16	<i>Screw TCEI M6X16</i>	Vis TCEI M6X16	<i>Schraube TCEI M6X16</i>	Tornillo TCEI M6X16
14	M07500002400	2	Antivibrante centralina	<i>Control unit damping pad</i>	Dispositif antivibratoire unité de contrôle	<i>Schwingungsdämpfer Steuerung</i>	Antivibrante centralita
15	M37100001400	1	Teleruttore avviamento	<i>Solenoid starter contactor</i>	Télérupteur démarrage	<i>Fernschalter Zündung</i>	Telerruptor de arranque
16	M01000031401	1	Vite M6X10	<i>Screw M6X10</i>	Vis M6X10	<i>Schraube M6X10</i>	Tornillo M6X10
17	M3510008600	1	Cavo da teleruttore a motorino d'avviamento	<i>Cable from solenoid starter to starter motor</i>	Câble du télérupteur. au démarreur	<i>Kabel vom Fernschalter zum Anlassmotor</i>	Cable del telerruptor al motor de arranque
18	M35100009600	1	Cavo batteria - teleruttore	<i>Solenoid starter battery cable</i>	Câble batterie - télérupteur	<i>Batteriekabel - Fernschalter</i>	Cable batería - telerruptor
19	M37000001400	1	Regolatore di tensione	<i>Voltage regulator</i>	Régulateur de tension	<i>Spannungsregler</i>	Reguladores de tensión
20	M01000010005	2	Vite TCEI M6X25	<i>Screw TCEI M6X25</i>	Vis TCEI M6X25	<i>Schraube TCEI M6X25</i>	Tornillo TCEI M6X25
21	M02000010401	2	Dado M6 flangiato autobloccante	<i>Self-locking M6 flanged nut</i>	Ecrou M6 de sécurité bridé	<i>Selbstsperrende M6 Flanschmutter</i>	Tuerca M6 embridada autoblocante
22	M03000012400	3	Rondella Ø 6X16X1.5	<i>Washer Ø 6X16X1.5</i>	Rondelle Ø 6X16X1.5	<i>Unterlegscheibe Ø 6X16X1.5</i>	Arandela Ø 6X16X1.5
23	M01000060401	1	Vite TE flangiata M10X12X1,25	<i>Flanged screw TE M10X12X1.25</i>	Vis-bride TE M10X12X1,25	<i>Flanschschraube TE M10X12X1,25</i>	Tornillo embridada TE M10X12X1,25
24	M01000031401	1	Vite M6X10	<i>Screw M6X10</i>	Vis M6X10	<i>Schraube M6X10</i>	Tornillo M6X10
25	M03000018400	1	Rondella ondulata per vite M6	<i>Washer for screw M6</i>	Rondelle ondulée pour vis M6	<i>Gewellte Unterlegscheibe. für Schraube M6</i>	Arandela ondulada para tornillo M6

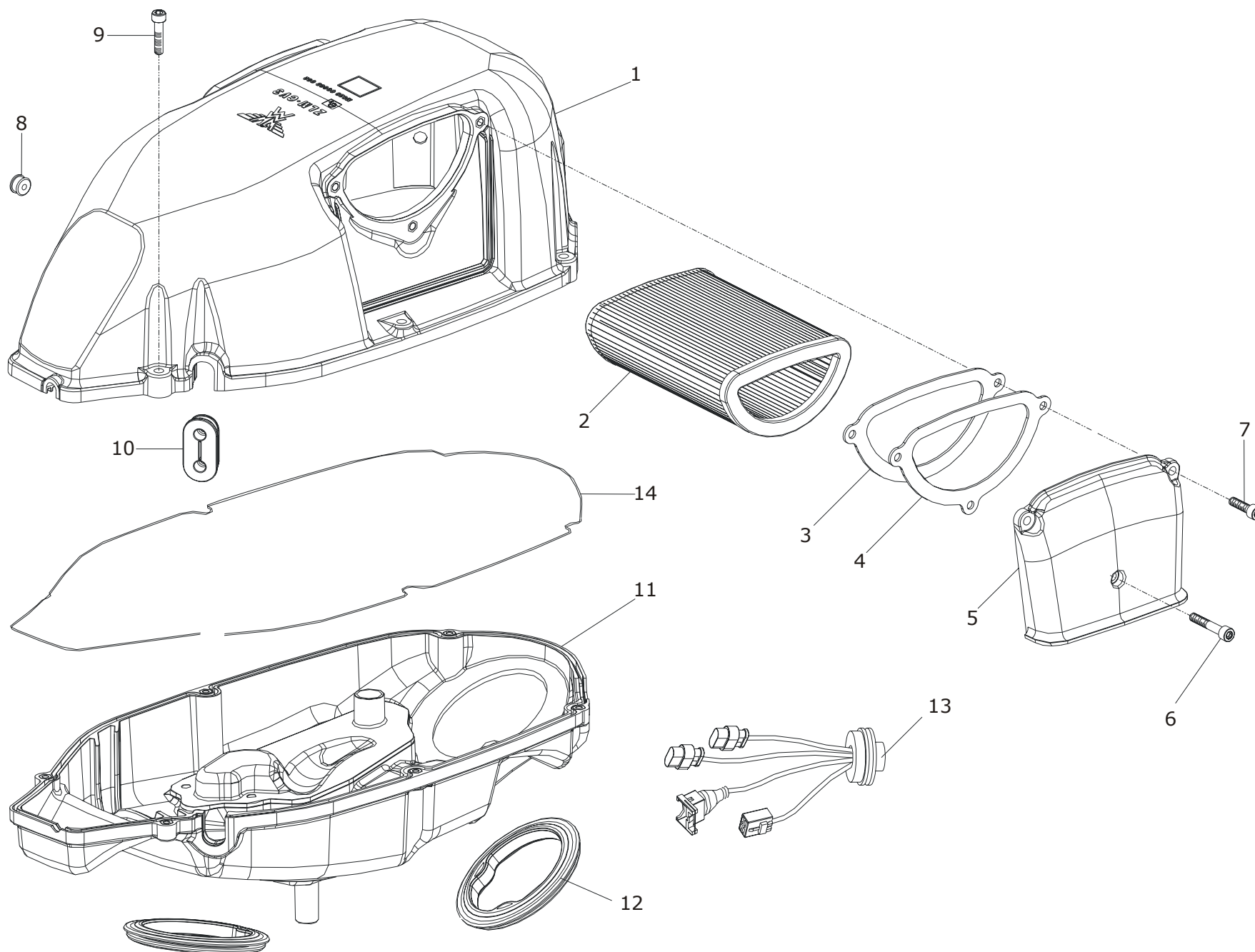



N°	Cod.	Q.	Descrizione	Description	Description	Beschreibung	Descripción
1	M82000003002	1	Semi airbox superiore	<i>Upper airbox</i>	Demi-boîte à air supérieure	<i>Semi Airbox oben</i>	Caja de aire superior
2	M82200002400	1	Filtro aria	<i>Air cleaner</i>	Filtre air	<i>Luftfilter</i>	Filtro aire
3	M2133001	2	Guarnizione flangia filtro aria	<i>Air cleaner flange gasket</i>	Joint bride Filtre air	<i>Flanschdichtung Luftfilter</i>	Junta brida Filtro aire
4	M82200004104	2	Flangia contenimento filtro	<i>air cleaner flange</i>	Bride boîtier filtre	<i>Halteflansch Filter</i>	Brida contenimento Filtro
5	M82200003002	2	Coperchio laterale scatola filtro	<i>Air box side cover</i>	Couvercle latéral boîte à filtre	<i>Seitenabdeckung Filterkasten</i>	Tapalateral caja filtro
6	M97600021400	2	Vite TORX TCB M6X35	<i>Screw TORX TCB M6X35</i>	Vis TORX TCB M6X35	<i>Schraube TORX TCB M6X35</i>	Tornillo TORX TCB M6X35
7	M97600017400	4	Vite TORX TCB M6X18	<i>Screw TORX TCB M6X18</i>	Vis TORX TCB M6X18	<i>Schraube TORX TCB M6X18</i>	Tornillo TORX TCB M6X18
8	M96600009400	1	Tappo, vite regolazione airbox	<i>Plag, Air box adjusting screw</i>	Capuchon, vis de réglage airbox	<i>Stopfen Regler airbox</i>	Tapón regulación caja de aire
9	M01000030401	6	Vite M5X22	<i>Screw M5X22</i>	Vis M5X22	<i>Schraube M5X22</i>	Tornillo M5X22
10	M2141041	1	Gommino ingresso cassa filtro	<i>Filter box ring</i>	Caoutchouc entrée boîte à filtre	<i>Gummi Eingang Filterkasten</i>	Goma entrada caja filtro
11	M82000005002	1	Semi airbox inferiore	<i>Lower airbox</i>	Demi-boîte à air inférieur	<i>Semi Airbox unten</i>	Caja de aire inferior
12	M40400004011	2	Gommino Airbox-corpo farfallato	<i>Ring airbox throttle</i>	Caoutchouc boîte à air vanne papillon	<i>Gummi Airbox Drosselklappenkörper</i>	Goma caja de aire cuerpo de mariposa
13	M35100004400	1	Cablaggio interno airbox	<i>Inner wiring airbox</i>	Câblage intér. boîte à air	<i>Innenverkabelung Airbox</i>	Cableado interno caja de aire
14	M40200004400	1	Guarnizione Ø 2,4	<i>Gasket Ø 2,4</i>	Garniture Ø 2,4	<i>Dichtung Ø 2,4</i>	Junta Ø 2,4



GRANPASSO
1200

Scarico - Exhaust - Échappement - Vergaser - Descarga

009

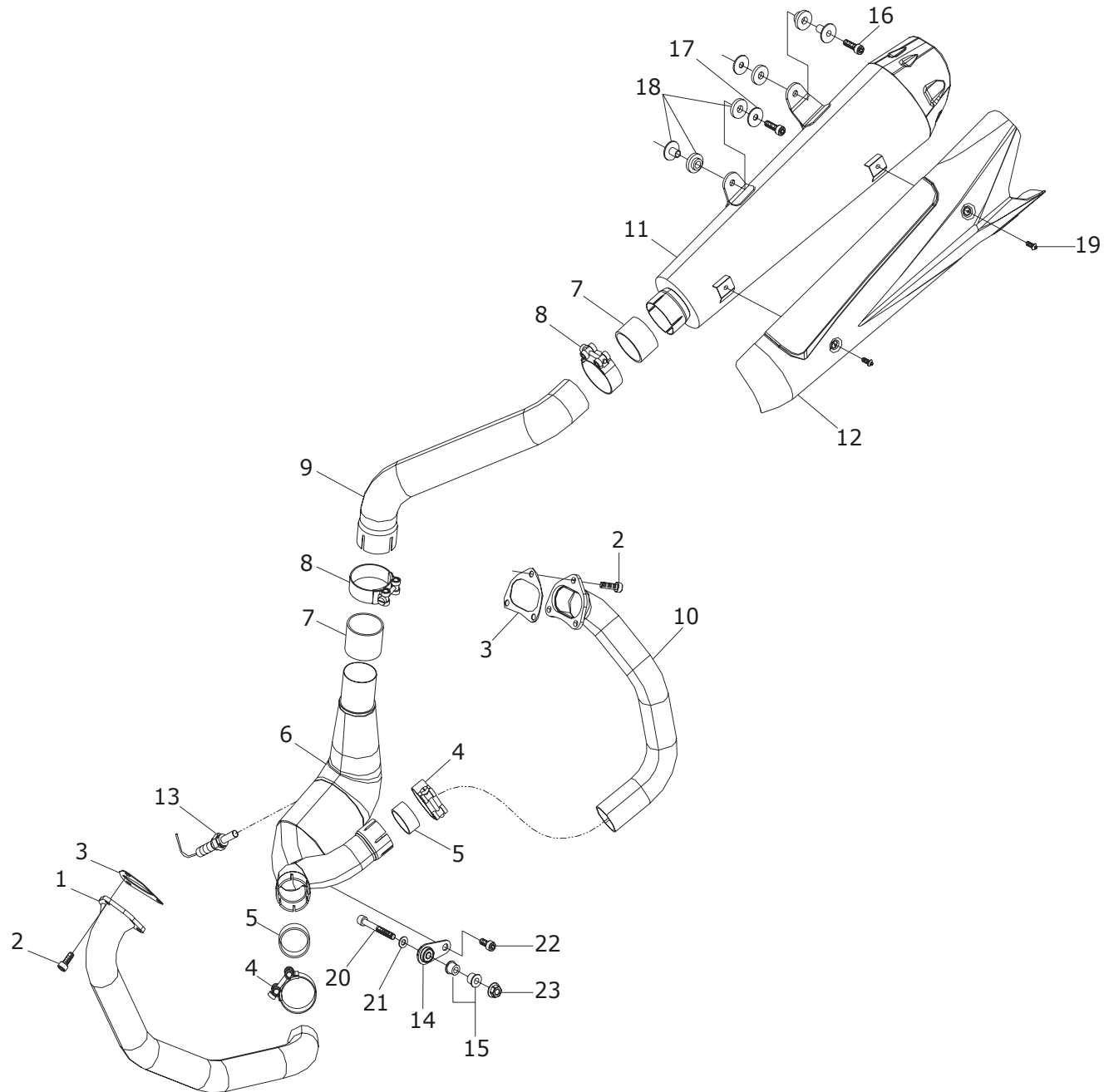

N°	Cod.	Q.	Descrizione	Description	Description	Beschreibung	Descripción
1	M2132021	1	Collettore cilindro anteriore	<i>Front cylinder manifold</i>	Collecteur cylindre avant	<i>Zylinderauspuff vorne</i>	Colector cilindro delantero
2	M01000004401	6	Vite M8X20	<i>Screw M8X20</i>	Vis M8X20	<i>Schraube M8X20</i>	Tornillo M8X20
3	M09000001012	2	Guarnizione flangia scarichi	<i>Exhaust pipe flange gasket</i>	Joint bridé échappement	<i>Flanschdichtung Auspuff</i>	Junta brida escape
4	M03600031400	2	Fascetta inox Ø 48-51	<i>Inox clamp Ø 48-51</i>	Collier inox Ø 48-51	<i>Klemme inox Ø 48-51</i>	Abrazadera inox Ø 48-51
5	M09000004400	2	Guarnizione tubi di scarico Ø 43-48	<i>Exhaust pipe gasket Ø 43-48</i>	Joint tuyau d'échappement Ø 43-48	<i>Dichtung Auspuffrohr Ø 43-48</i>	Junta tubo de escape Ø 43-48
6	M2132051	1	Collettore centrale con catalizzatore	<i>Central manifold with catalytic converter</i>	Collecteur central équipé de catalyseur	<i>Zentraler Auspuff mit Katalysator</i>	Colector central con catalizador
7	M09000005000	2	Guarnizione silenziatore Ø 49X30	<i>Silencer gasket Ø 49X30</i>	Joint silencieux Ø 49X30	<i>Dichtung Schalldämpfer Ø 49X30</i>	Junta silenciador Ø 49X30
8	M03600033400	2	Fascetta inox Ø 56-59	<i>Inox clamp Ø 56-59</i>	Collier inox Ø 56-59	<i>Klemme inox Ø 56-59</i>	Abrazadera inox Ø 56-59
9	M2132101	1	Tronchetto silenziatore	<i>Silencer mid-section</i>	Embout silencieux	<i>Schalldämpferstutzen</i>	Tubuladura de escape
10	M2132031	1	Collettore cilindro posteriore	<i>Rear cylinder manifold</i>	Collecteur cylindre arrière	<i>Zylinderauspuff hinten</i>	Colector cilindro trasero
11	M2132071	1	Silenziatore	<i>Silencer</i>	Silencieux	<i>Schalldämpfer</i>	Silenciador
12	M2132111 59	1	Paracalore	<i>Heat guard</i>	Pare-chaleur	<i>Hitzeschutz</i>	Protección calor
13	M31500001400	1	Sonda lambda	<i>Lambda sensor</i>	Sonde Lambda	<i>Lambda Sonde</i>	Sonda Lambda
14	M17700006000	1	Bielletta silent-block	<i>Silent-block connection rod</i>	Bielle Silentbloc	<i>Pleuel Silentblock</i>	Biela Silent-Block
15	M07000016000	2	Distanziale silent-block scarico centrale	<i>Central exhaust pipe silent-block spacer</i>	Entretoise Silentbloc échappement central	<i>Distanzscheibe Silentblock Zentralauspuff</i>	Distanciador Silent-Block escape central
16	M01000032401	1	Vite M8X30	<i>Screw M8X30</i>	Vis M8X30	<i>Schraube M8X30</i>	Tornillo M8X30
17	M03000025104	2	Rondella Ø 28X8X1.8	<i>Washer Ø 28X8X1.8</i>	Rondelle Ø 28X8X1.8	<i>Unterlegscheibe Ø 28X8X1.8</i>	Arandela Ø 28X8X1.8
18	M40300003400	2	Silent block fissaggio silenziatore	<i>Exhaust pipe fastening silent-block</i>	Silentbloc fixation silencieux	<i>Silentblock Befestigung Schalldämpfer</i>	Silentbloc fijación silencioso
19	M005204610	2	Vite TBEI M5X12	<i>Screw M5X12</i>	Vis M5X12	<i>Schraube M5X12</i>	Tornillo M5X12
20	M005013210	1	Vite TCEI M8X60	<i>Screw M8X60</i>	Vis M8X60	<i>Schraube M8X60</i>	Tornillo M8X60
21	M03000014400	1	Rondella Ø 8,5X16	<i>Washer Ø 8.5X16</i>	Rondelle Ø 8,5X16	<i>Unterlegscheibe Ø 8,5X16</i>	Arandela Ø 8,5X16
22	M01000038401	1	Vite M8X12	<i>Screw M8X12</i>	Vis M8X12	<i>Schraube M8X12</i>	Tornillo M8X12
23	M02000030401	1	Dado M8 flangiato autobloccante	<i>Self-locking flanged nut M8</i>	Ecrou bridé M8 de sécurité	<i>Selbstsperrende M8 Flanschmutter</i>	Tuerca embriada M8 autoblocante



GRANPASSO
1200

**Pedana pilota destra - Driver right rear footpeg - Repose-pied pilote dt -
Fahrertrittbrett rechts - Plataforma piloto der.**

010

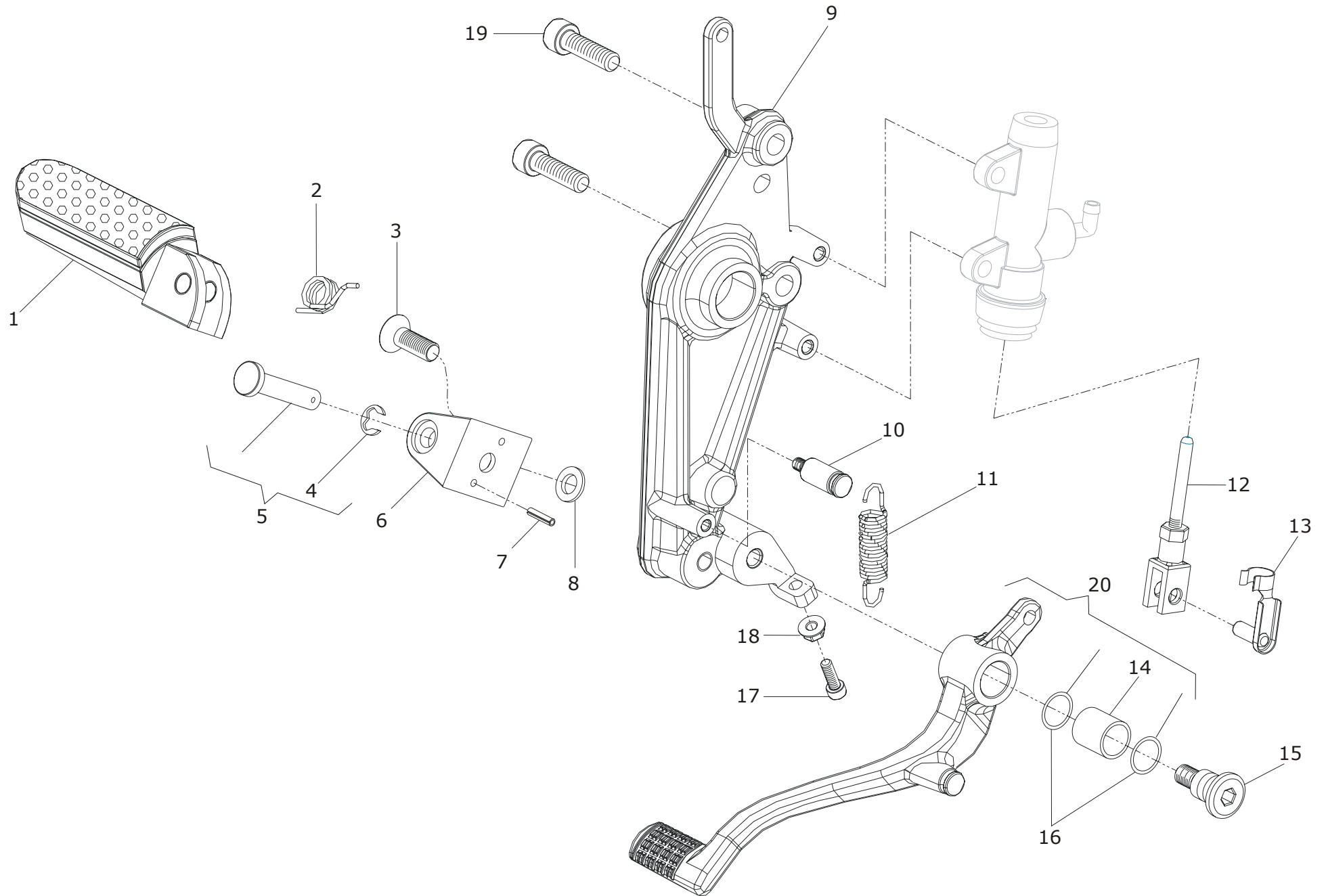

N°	Cod.	Q.	Descrizione	Description	Description	Beschreibung	Descripción
1	M16900003300	1	Pedana pilota destra	<i>Rear right driver footpeg</i>	Repose-pied pilote dt	<i>Fahrertrittbrett rechts</i>	Plataforma piloto der.
2	M09100003400	1	Molla pedana pilota	<i>Driver footpeg spring</i>	Ressort repose-pied pilote	<i>Feder Fahrertrittbrett</i>	Muelle plataforma piloto
3	M01000086104	1	Vite a testa svasata M8X16	<i>Flat head screw M8X16</i>	Vis à tête noyée M8X16	<i>Senkkopfschraube M8X16</i>	Tornillo de cabeza M8X16 avellanada
4	M0066107	1	Anello elastico radiale 9	<i>Elastic ring radial 9</i>	Bague élastique radiale 9	<i>Radialer Federring 9</i>	Anillo elástico radial 9
5	R2141010	1	Perno con anello elastico	<i>Shaft with elastic ring</i>	Axe d'entraînement avec bague élastique	<i>Zapfen mit Federring</i>	Perno con anillo elástico
6	M2141351	1	Forchetta pedana dx	<i>Right footpeg fork</i>	Fourchette repose-pied dt	<i>Schaltgabel Tritt Brett re.</i>	Horquilla plataforma der.
7	M0065002	1	Spina elastica 3X10	<i>Elastic pin 3X10</i>	Goupille élastique 3X10	<i>Spannstift 3X10</i>	Pasador elástico 3X10
8	M0063040	1	Rondella Ø 8X14X1,5	<i>Washer Ø 8X14X1.5</i>	Rondelle Ø 8X14X1,5	<i>Unterlegscheibe Ø 8X14X1,5</i>	Arandela Ø 8X14X1,5
9	M214102139	1	Supporto pedana dx	<i>Right footpeg guard</i>	Support repose-pied dt	<i>Halterung Tritt Brett re.</i>	Soporte plataforma der.
10	M06000015111	1	Perno molla freno	<i>Brake spring spindle</i>	Pivot ressort frein	<i>Zapfen Bremsfeder</i>	Perno muelle freno
11	M09110002628	1	Molla leva freno	<i>Brake lever spring</i>	Ressort levier de frein	<i>Bremshebelfeder</i>	Muelle palanca freno
12	M09620001300	1	Puntalino leva freno	<i>Brake air dam</i>	Pointeau levier de frein	<i>Bremsspitze</i>	Puntal freno
13	M09300001400	1	Clip tirante freno posteriore	<i>Rear brake linkage</i>	Clip tirant frein arrière	<i>Klemme Bremsstange hinten</i>	Clip tirante freno trasero
14	M05100001400	1	Bronzina leva freno posteriore	<i>Rear brake lever brass bearing</i>	Coussinet levier frein arrière	<i>Bronzelager Bremshebel hinten</i>	Cojinete de bronce palanca freno trasero
15	M06000009401	1	Perno leva freno posteriore	<i>Rear brake lever spindle</i>	Pivot levier frein arrière	<i>Bremshebelzapfen hinten</i>	Perno palanca freno trasero
16	M03100001400	2	O-Ring leva comando freno	<i>Brake lever o-ring</i>	Joint torique levier commande de frein	<i>O-Ring Steuerhebel Bremse</i>	O-Ring palanca de mando freno
17	M01000049401	1	Vite M5X20	<i>Screw M5X20</i>	Vis M5X20	<i>Schraube M5X20</i>	Tornillo M5X20
18	M02000014401	1	Dado M5	<i>Nut M5</i>	Ecrou M5	<i>Mutter M5</i>	Tuerca M5
19	M01000032401	2	Vite M8X30	<i>Screw M8X30</i>	Vis M8X30	<i>Schraube M8X30</i>	Tornillo M8X30
20	M16500001300	1	Leva freno posteriore completa	<i>Complete rear brake lever</i>	Levier frein arrière complet	<i>Lager Bremshebel hinten komplett</i>	Palanca freno trasero completa



GRANPASSO
1200

**Pedana pilota sinistra - Driver left rear footpeg - Repose-pied pilote gche -
Fahrertrittbrett links - Plataforma piloto izq.**

011

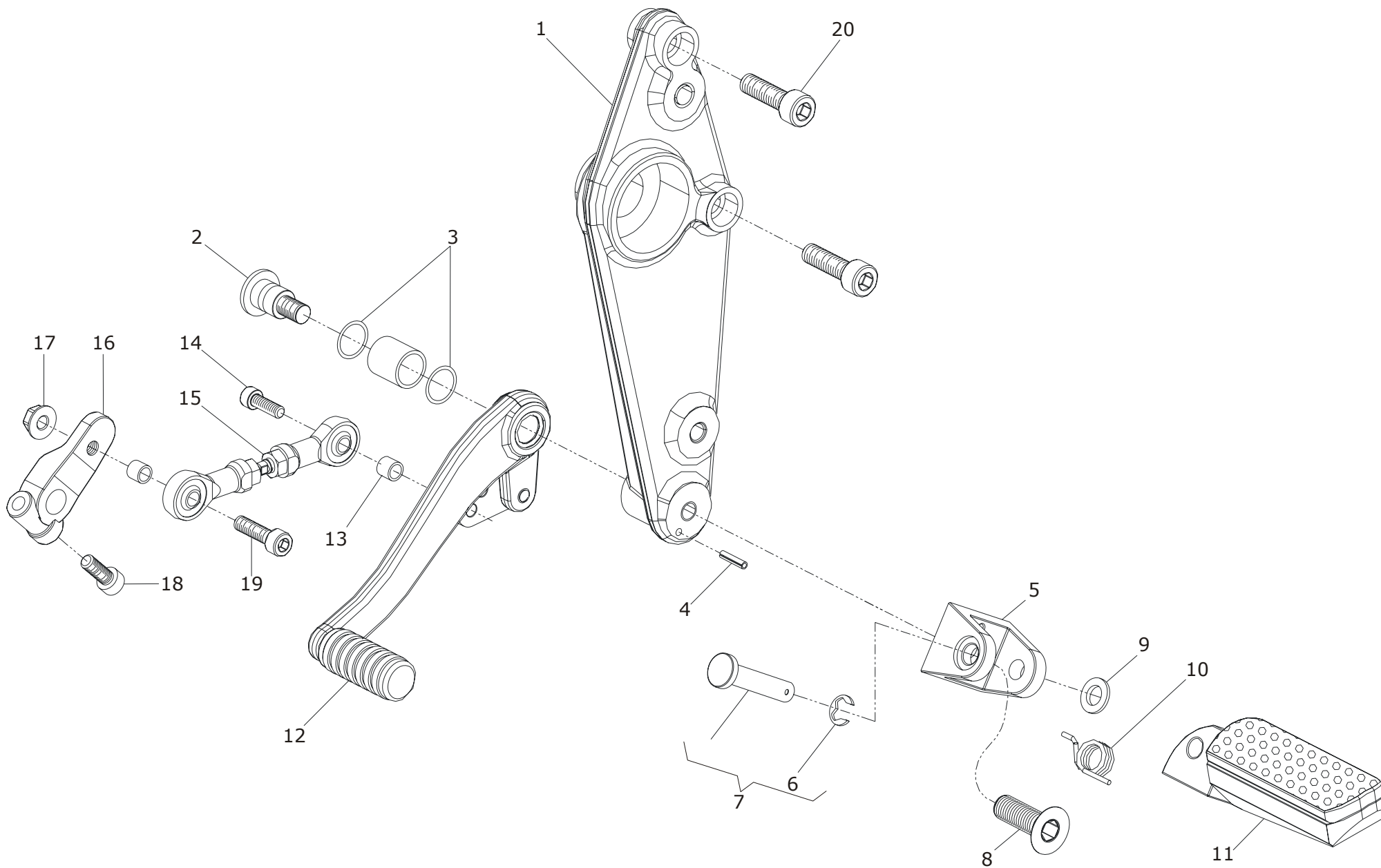

N°	Cod.	Q.	Descrizione	Description	Description	Beschreibung	Descripción
1	M214112139	1	Supporto pedana sx	<i>Left footpeg guard</i>	Support repose-pied gche	<i>Trittbrethalterung links</i>	Soporte plataforma izq.
2	M06000010401	1	Perno leva cambio	<i>Gear shift lever spindle</i>	Axe levier boîte de vitesses	<i>Schalthebelbolzen</i>	Perno palanca cambio
3	M03100001400	2	O-Ring leva cambio	<i>Gear shift lever o-ring</i>	Joint torique levier de vitesse	<i>O-Ring Gangschalthebel</i>	O-Ring palanca cambio
4	M0065002	1	Spina elastica 3X10	<i>Elastic pin 3X10</i>	Goupille élastique 3X10	<i>Spannstift 3X10</i>	Pasador elástico 3X10
5	M2141361	1	Forchetta pedana	<i>Footpeg fork</i>	Fourchette repose-pied	<i>Schaltgabel Trittbrett</i>	Horquilla plataforma
6	M0066107	1	Anello elastico radiale 9	<i>Elastic ring radial 9</i>	Bague élastique radiale 9	<i>Radialer Federring 9</i>	Anillo elástico radial 9
7	R2141010	1	Perno con anello elastico	<i>Shaft with elastic ring</i>	Axe d'entraînement avec bague élastique	<i>Zapfen mit Federring</i>	Perno con anillo elástico
8	M01000086104	1	Vite TS M8X16 inox	<i>Screw TS M8X16 inox</i>	Vis TS M8X16 inox	<i>Schraube TS M8X16 inox</i>	Tornillo TS M8X16 inox
9	M0063040	1	Rondella Ø 8X14X1,5	<i>Washer Ø 8X14X1,5</i>	Rondelle Ø 8X14X1,5	<i>Unterlegscheibe Ø 8X14X1,5</i>	Arandela Ø 8X14X1,5
10	M09100003400	1	Molla pedana pilota	<i>Driver footpeg spring</i>	Ressort repose-pied pilote	<i>Feder Fahrertrittbrett</i>	Muelle plataforma piloto
11	M16900004104	1	Pedana pilota sx	<i>Left driver footpeg</i>	Repose-pied pilote gche	<i>Fahrertrittbrett links</i>	Plataforma piloto izq.
12	M2141250	1	Leva comando cambio completa	<i>Complete gear shift lever</i>	Levier de vitesse complet	<i>Gangschalthebel komplett</i>	Palanca de mando cambio completa
13	M2141411	2	Distanziale	<i>Spacer</i>	Entretoise	<i>Distanzscheibe</i>	Distanciadore
14	M01000014401	1	Vite M6X30	<i>Screw M6X30</i>	Vis M6X30	<i>Schraube M6X30</i>	Tornillo M6X30
15	M2141300	1	Asta rinvio cambio completa	<i>Complete gear shift transmission lever</i>	Axe renvoi boîte de vitesses complet	<i>Stab Wechselschaltung komplett</i>	Varilla ritorno cambio completa
16	M16520003102	1	Bielletta cambio	<i>Gear lever connecting rod</i>	Bielle levier de vitesse	<i>Pleuelstange Gangschaltung</i>	Biela cambio
17	M02000010401	1	Dado M6 flangiato autobloccante	<i>Self-locking flanged nut M6</i>	Ecrou-bride M6 de sécurité	<i>Selbstsperrende M6 Flanschmutter</i>	Tuerca embridada M6 autoblocante
18	M01000013401	1	Vite 6X20	<i>Screw 6X20</i>	Vis 6X20	<i>Schraube 6X20</i>	Tornillo 6X20
19	M01000014401	1	Vite M6X30	<i>Screw M6X30</i>	Vis M6X30	<i>Schraube M6X30</i>	Tornillo M6X30
20	M01000032401	2	Vite M8X30	<i>Screw M8X30</i>	Vis M8X30	<i>Schraube M8X30</i>	Tornillo M8X30



GRANPASSO
1200

**Pedana passeggero destra - Right passenger footpeg - Repose pied droit
passager - Beifahrertrittbrett rechts - Plataforma pasajero derecha**

012

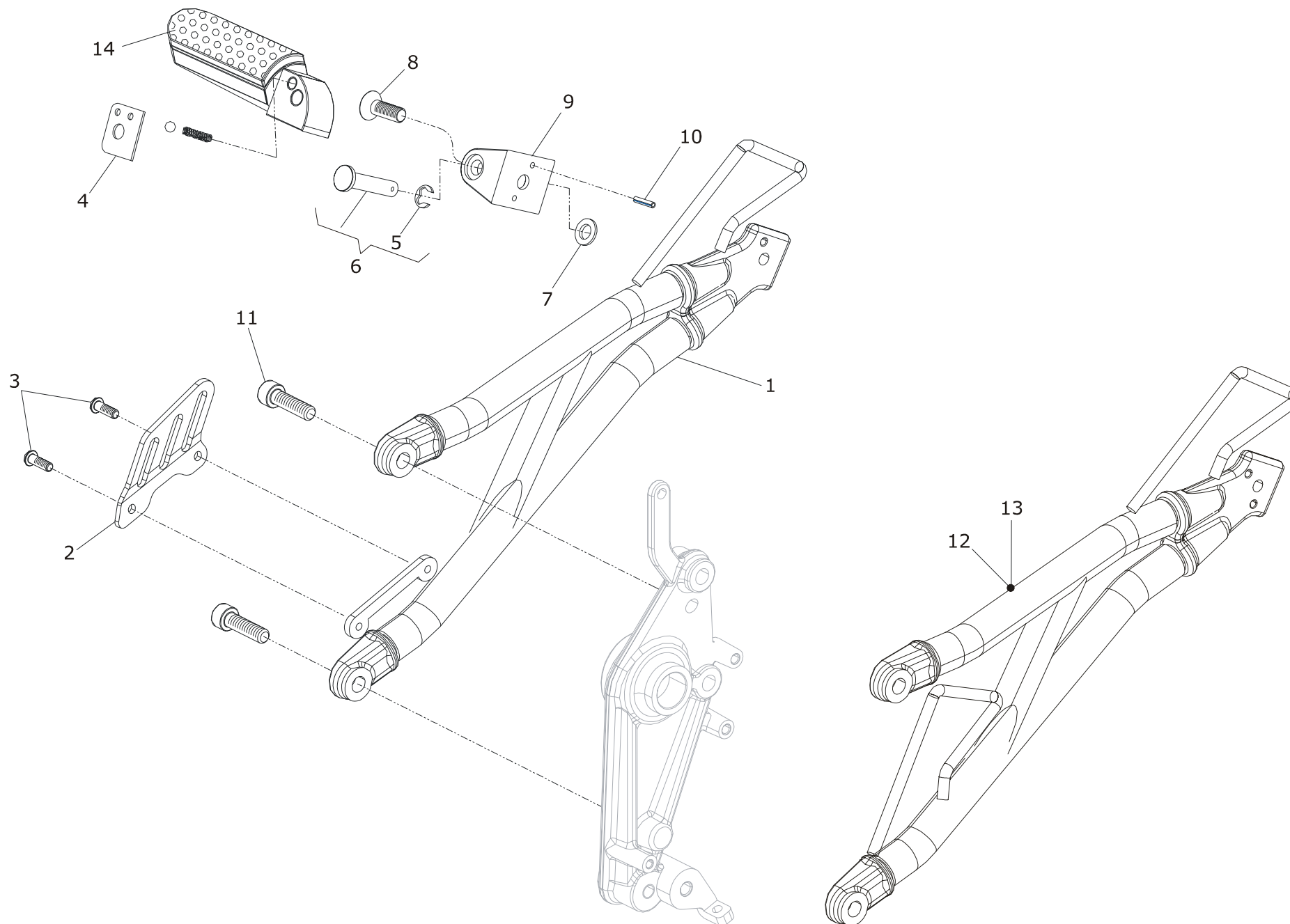

N°	Cod.	Q.	Descrizione	Description	Description	Beschreibung	Descripción
* 1	M2141030	1	Traliccio supporto pedana dx.	<i>Right footpeg support</i>	Treillis support repose-pied dt	<i>Rohrrahmen Halterung Trittbrett rechts</i>	Marco de tubos soporte plataforma der.
2	M2141321	2	Protezione pedana pilota dx	<i>Driver footpeg right protection</i>	Protection repose-pied pilote dt	<i>Schutz Fahrertrittbrett rechts</i>	Protección plataforma piloto der.
3	M01000025401	2	Vite TCBEI M5X8	<i>Screw TCBEI M5X8</i>	Vis TCBEI M5X8	<i>Schraube TCBEI M5X8</i>	Tornillo TCBEI M5X8
4	M2141281	1	Lamierino pedana passeggero	<i>Passanger footpeg plate</i>	Tôle repose-pied passager	<i>Blech Beifahrertrittbrett</i>	Chapa plataforma pasajero
5	M0066107	1	Anello elastico radiale 9	<i>Elastic ring radial 9</i>	Bague élastique radiale 9	<i>Radialer Federring 9</i>	Anillo elástico radial 9
6	R2141010	1	Perno con anello elastico	<i>Shaft with elastic ring</i>	Axe d'entraînement avec bague élastique	<i>Zapfen mit Federring</i>	Perno con anillo elástico
7	M0063040	1	Rondella Ø 8X14X1,5	<i>Washer Ø 8X14X1.5</i>	Rondelle Ø 8X14X1,5	<i>Unterlegscheibe Ø 8X14X1,5</i>	Arandela Ø 8X14X1,5
8	M01000086104	1	Vite TS M8X16	<i>Flat head screw M8X16</i>	Vis à tête noyée M8X16	<i>Senkkopfschraube M8X16</i>	Tornillo de cabeza M8X16 avellanada
9	M2141351	1	Forchetta pedana dx	<i>Right footpeg fork</i>	Fourchette repose-pied dt	<i>Schaltgabel Trittbrett re.</i>	Horquilla plataforma der.
10	M0065002	1	Spina elastica 3X10	<i>Elastic pin 3X10</i>	Goupille élastique 3X10	<i>Spannstift 3X10</i>	Pasador elástico 3X10
11	M01000004401	2	Vite M8X20	<i>Screw M8X20</i>	Vis M8X20	<i>Schraube M8X20</i>	Tornillo M8X20
12	R214102040	1	Traliccio supporto pedana dx, nero, completo	<i>Right footpeg guard, support shaft black, complete</i>	Treillis support repose-pied droit, noir, complet	<i>Rohrrahmen Halterung Trittbrett rechts, Schwarz, komplett</i>	Marco de tubos soporte plataforma der., negro, completo
13	R214102041	1	Traliccio supporto pedana dx, rosso, completo	<i>Right footpeg guard, red, complete</i>	Treillis support repose-pied droit, rouge, complet	<i>Rohrrahmen Halterung Trittbrett rechts, Rot, komplett</i>	Marco de tubos soporte plataforma der., rojo, completo
14	M16900005300	1	Pedana passeggero destra	<i>Right passenger footpeg</i>	Repose pied droit passager	<i>Beifahrertrittbrett rechts</i>	Plataforma pasajero derecha

(*) Specificare colore - Specify colour - Spécifier le coloris - Farbe angeben - Especificar color

COLORI - COLOURS - COLORIS - FARBEN - COLORES			
N°	Cod.	Nero - Black - Noir - Schwarz - Negro	Rosso - Red - Rouge - Rot - Rojo
1	M2141030 - - -	213	651



GRANPASSO
1200

**Pedana passeggero sinistra - Left passenger footpeg - Repose-pied gauche
passager - Beifahrertrittbrett links - Plataforma pasajero izquierda**

013

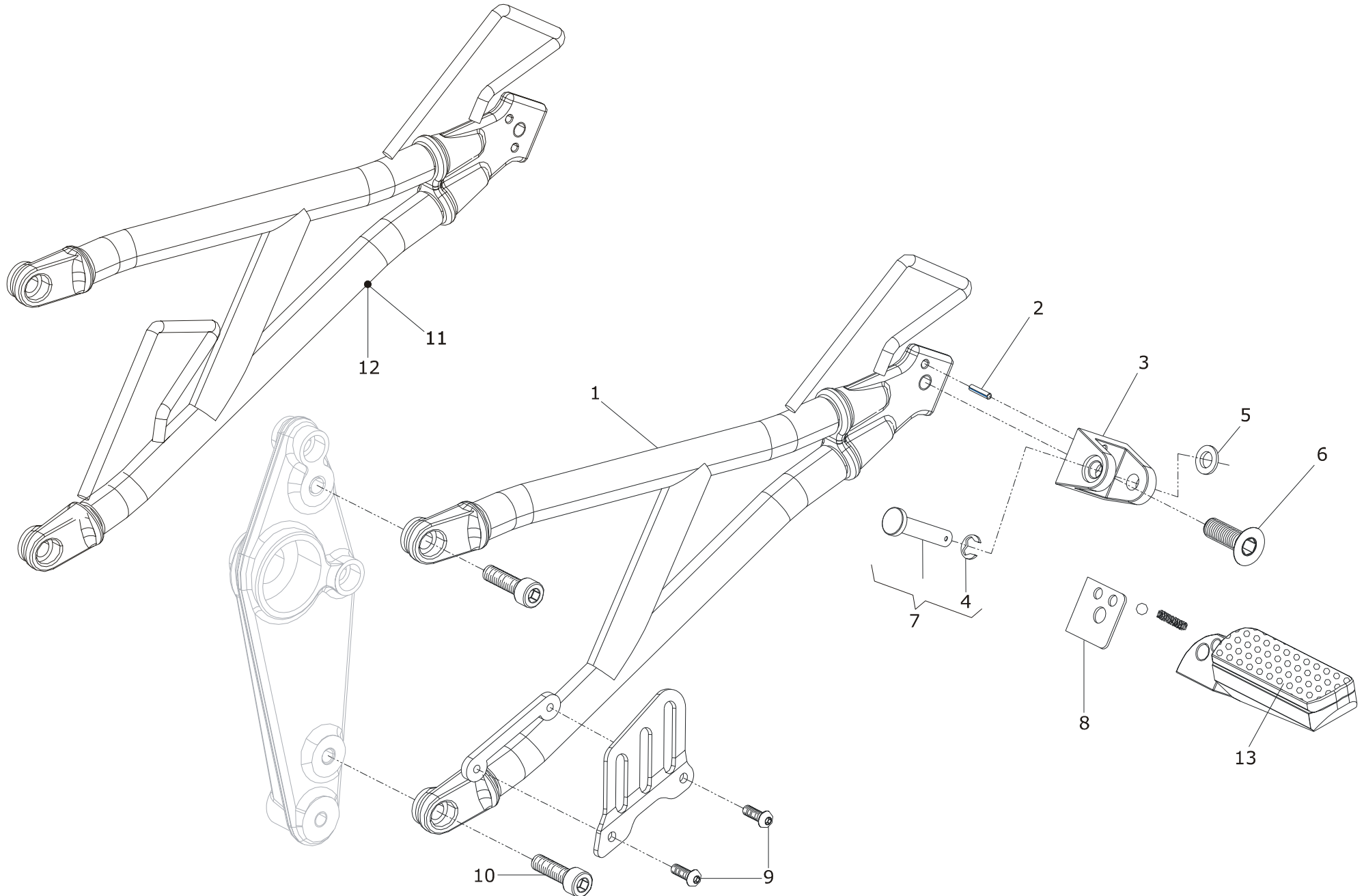

N°	Cod.	Q.	Descrizione	Description	Description	Beschreibung	Descripción
* 1	M2141130	1	Traliccio supporto pedana sx.	<i>Left footpeg support</i>	Treillis support. repose-pied gche	<i>Rohrrahmen Halterung Trittbrett links</i>	Marco de tubos soporte plataforma izq.
2	M0065002	1	Spina elastica 3X10	<i>Elastic pin 3X10</i>	Goupille élastique 3X10	<i>Spannstift 3X10</i>	Pasador elástico 3X10
3	M2141361	1	Forchetta pedana sx	<i>Left footpeg fork</i>	Fourchette repose-pieds gche	<i>Schaltgabel Trittbrett li.</i>	Horquilla plataforma izq.
4	M0066107	1	Anello elastico radiale 9	<i>Elastic ring radial 9</i>	Bague élastique radiale 9	<i>Radialer Federring 9</i>	Anillo elástico radial 9
5	M0063040	1	Rondella Ø 8X14X1,5	<i>Washer Ø 8X14X1.5</i>	Rondelle Ø 8X14X1,5	<i>Unterlegscheibe Ø 8X14X1,5</i>	Arandela Ø 8X14X1,5
6	M01000086104	1	Vite TS M8X16	<i>Screw TS M8X16</i>	Vis TS M8X16	<i>Schraube TS M8X16</i>	Tornillo TS M8X16
7	R2141010	1	Perno con anello elastico	<i>Shaft with elastic ring</i>	Axe d'entraînement avec bague élastique	<i>Zapfen mit Federring</i>	Perno con anillo elástico
8	M2141281	1	Lamierino pedana passeggero	<i>Passanger footpeg plate</i>	Tôle repose-pied passager	<i>Blech Beifahrertrittbrett</i>	Chapa plataforma pasajero
9	M01000025401	2	Vite TCBEI M5X8	<i>Screw TCBEI M5X8</i>	Vis TCBEI M5X8	<i>Schraube TCBEI M5X8</i>	Tornillo TCBEI M5X8
10	M01000004401	2	Vite M8X20	<i>Screw M8X20</i>	Vis M8X20	<i>Schraube M8X20</i>	Tornillo M8X20
11	R214103040	1	Traliccio supporto pedana sx, nero, completo	<i>Left footpeg guard, support shaft black, complete</i>	Treillis support repose-pied gche, noir, complet	<i>Rohrrahmen Halterung Trittbrett links, Schwarz, komplett</i>	Marco de tubos soporte plataforma izq., negro, completo
12	R214103041	1	Traliccio supporto pedana sx, rosso, completo	<i>Left footpeg guard, support shaft red, complete</i>	Treillis support repose-pied, gche, rouge, complet	<i>Rohrrahmen Halterung Trittbrett links, Rot, komplett</i>	Marco de tubos soporte plataforma izq., rojo, completo
13	M16900006300	1	Pedana passeggero sinistra	<i>Left passanger footpeg</i>	Repose pied gauche passager	<i>Beifahrertrittbrett links</i>	Plataforma pasajero izquierda

(*) Specificare colore - Specify colour - Spécifier le coloris - Farbe angeben - Especificar color

COLORI - COLOURS - COLORIS - FARBEN - COLORES			
N°	Cod.	Nero - Black - Noir - Schwarz - Negro	Rosso - Red - Rouge - Rot - Rojo
1	M2141130 - - -	213	651



GRANPASSO
1200

Forcella - Fork - Fourche - Gabel - Horquilla

014

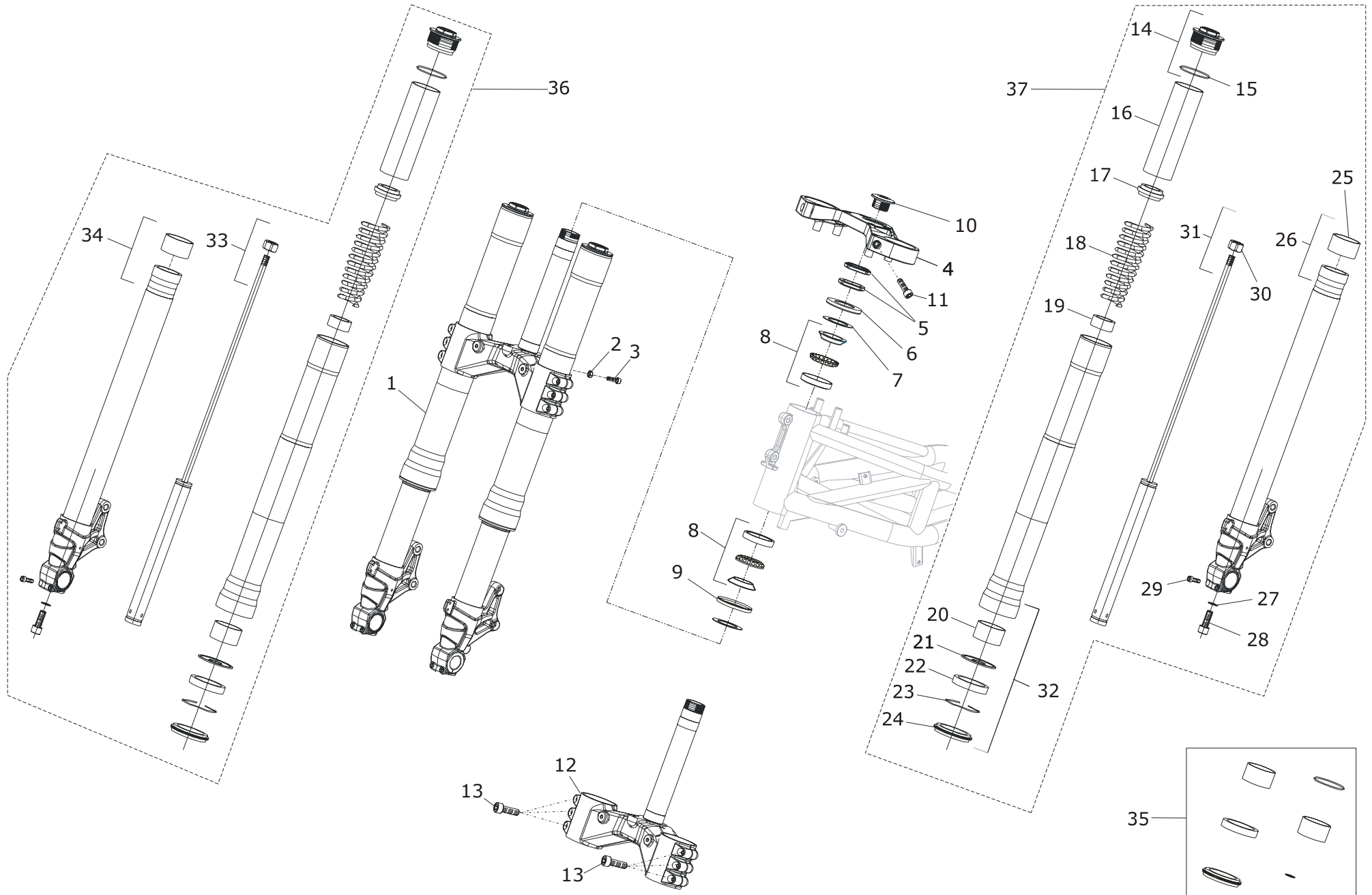

N°	Cod.	Q.	Descrizione	Description	Description	Beschreibung	Descripción
1	M19600009304	1	Forcella completa	Complete fork	Fourche complète	Gabelkomplett	Horquilla completa
2	M02000006401	1	Dado M6	Nut M6	Ecrou M6	Mutter M6	Tuerca M6
3	M01000013401	1	Vite M6X20	Screw M6X20	Vis M6X20	Schraube M6X20	TornilloM6X20
4	M13500006000	1	Testa di sterzo	Steering head	Tête de direction	Lenkkopf	Cabezal de dirección
5	M03500001402	2	Ghiera M35X1	Ring nut M35X1	Anneau de renfort M35X1	Hülle M35X1	Capuchón roscado M35X1
6	M03000007300	1	Cappello tubo canotto completo	Complete steering head mounting cap	Capot tube complet	Kappe Lenkrohr komplett	Sombbrero tubo de dirección completo
7	M03000005113	2	Rondella canotto	Steering head washer	Rondelle tube	Unterlegscheibe Lenkrohr	Arandela tubo de dirección
8	M08000001400	2	Cuscinetto	Bearing	Coussinet	Lager	Cojinete
9	M03000022300	1	Tappo inferiore canotto	Steering head plug	Bouchon inférieur tube	Unterer Schaftdeckel	Tapón inferior manguito
10	M01000016111	1	Vite testa di sterzo	Steering head screw	Vis tête de direction	Schraube Schaftkopf	Tornillo cabeza de conducción
11	M19500010300	2	Vite TCEI M8X25	Screw TCEI M8X25	Vis TCEI M8X25	Schraube TCEI M8X25	Tornillo TCEI M8X25
12	M2139041	1	Testa croce inferiore	Lower fork head	Tête de piston	Unteres Kreuzkopfstück	Cabeza cruz inferior
13	M19500011300	6	Vite TCEI M6X20	Screw TCEI M6X20	Vis TCEI M6X20	Schraube TCEI M6X20	Tornillo TCEI M6X20
14	M19500040400	2	Tappo canna	Fork rod rubber plug	Bouchon fût	Stangendeckel	Tapa leva
15	M0069002	2	OR 3193 (D48.89 S2.62)	OR 3193 (D48.89 S2.62)	OR 3193 (D48.89 S2.62)	OR 3193 (D48.89 S2.62)	OR 3193 (D48.89 S2.62)
16	R2139011	2	Tubo interno	Inner pipe	Tube interne	Innendraht	Tubo interno
17	M19500017300	2	Guida molla superiore	Upper spring guide	Guide-ressort supérieur	Federführung oben	Guía muelle superior
18	R2139021	2	Molla	Spring	Ressort	Feder	Muelle
19	M19500015300	2	Guida molla inferiore	Lower spring guide	Guide-ressort inférieur	Federführung unten	Guía muelle inferior
20	M19500025300	2	Boccola	Bushing	Bague	Buchse	Casquillo
21	M19500024300	2	Scodellino	Shim cap	Cuvette	Federteller	Cazoleta
22	M19500023300	2	Anello di tenuta Ø 50X63X11	Seal ring Ø 50X63X11	Bague d'étanchéité Ø 50X63X11	Dichtring Ø 50X63X11	Anillo de estanqueidad Ø 50X63X11
23	M19500022300	2	Anello di fermo Ø 68	Stop ring Ø 68	Bague d'arrêt Ø 68	Sicherungsring Ø 68	Anillo de tope Ø 68
24	M19500021300	2	Raschiapolvere	Dust seal	Cache-poussière	Staubschaber	Rasca polvo
25	M19500008300	2	Boccola	Bushing	Bague	Buchse	Casquillo
26	M2139070	1	Canna sx	Left fork rod	Fût gche	Schaft links	Leva izq.
27	M19500005300	2	Rondella Ø 10	Washer Ø 10	Rondelle Ø 10	Unterlegscheibe Ø 10	Arandela Ø 10



GRANPASSO
1200

Forcella - Fork - Fourche - Gabel - Horquilla

014

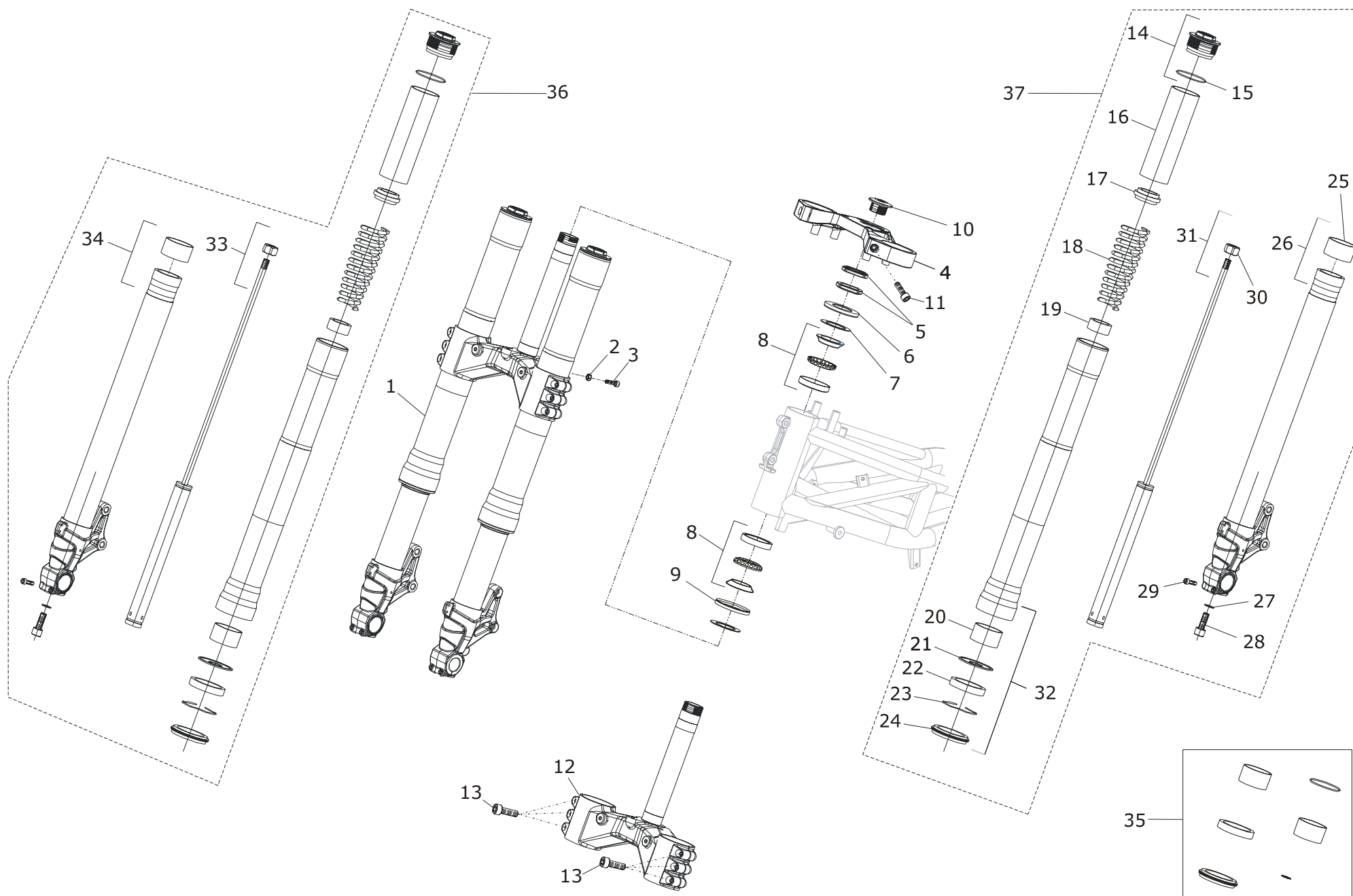

N°	Cod.	Q.	Descrizione	Description	Description	Beschreibung	Descripción
28	M19500004300	2	Vite TCEI M10X25	<i>Screw TCEI M10X25</i>	Vis TCEI M10X25	<i>Schraube TCEI M10X25</i>	Tornillo TCEI M10X25
29	M19500006300	4	Vite TCEI M6X30	<i>Screw TCEI M6X30</i>	Vis TCEI M6X30	<i>Schraube TCEI M6X30</i>	Tornillo TCEI M6X30
30	M19500045400	2	Dado M8	<i>M8 nut</i>	Ecrou M8	<i>Mutter M8</i>	Tuerca M8
31	R2139041	1	Gruppo asta sx	<i>Left rod unit</i>	Groupe tige gche	<i>Stangengruppe links</i>	Grupo varilla izq.
32	M19500003401	2	Gr. tubone Ø 50 ricambio 131844	<i>Pipe unit Ø 50 ricambio 131844</i>	Gr. Grand tube Ø 50 p. détachée 131844	<i>Gruppe Äusseres Rohr Ø 50 Ersatzteil 131844</i>	Grupo tubo exterior Ø 50 repuesto 131844
33	R2139031	1	Gruppo asta dx	<i>Right rod unit</i>	Groupe tige dte	<i>Stangengruppe rechts</i>	Grupo varilla der.
34	M2139060	1	Canna dx	<i>Right fork rod</i>	Fût droit	<i>Schaft rechts</i>	Leva der.
35	M19500019300	1	Kit revisione	<i>Overhaul kit</i>	Kit révision	<i>Überholungskit</i>	Kit de revisión
36	R2139051	1	Stelo dx completo	<i>Fork leg assy right</i>	Tige dte complet	<i>Schaft rechts komplett</i>	Vástago der. completo
37	R2139061	1	Stelo sx completo	<i>Fork leg assy left</i>	Tige gche complet	<i>Schaft links komplett</i>	Vástago izq. completo



GRANPASSO
1200

**Forcellone/Ammortizzatore - Swing arm/Shock absorber - Bras oscillant/
Amortisseur - Federbein/Stoßdämpfer - Horquilla/Amortiguador**

015

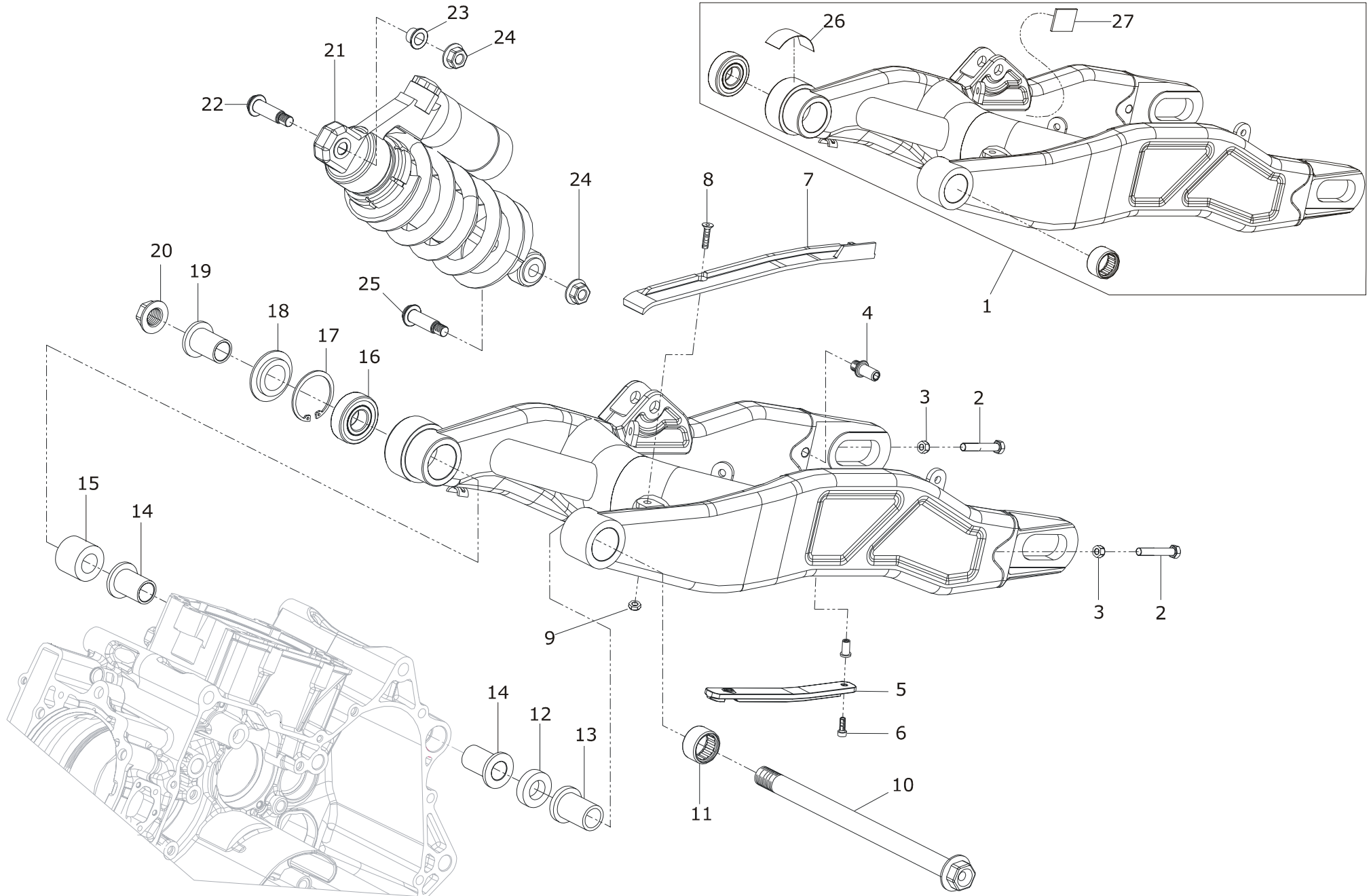

**GRANPASSO**
1200**Forcellone/Ammortizzatore - Swing arm/Shock absorber - Bras oscillant/
Amortisseur - Federbein/Stoßdämpfer - Horquilla/Amortiguador****015**

N°	Cod.	Q.	Descrizione	Description	Description	Beschreibung	Descripción
1	R2138010	1	Forcellone completo, grigio	Complete swing arm, gray	Bras oscillant complet, gris	Gabel komplett, Grau	Horquilla completa, gris
2	M2138351	2	Vite registro ruota M8X55 - chiave 10	Wheel adjusting screw M8X55 - wrench 10	Vis réglleur de roue M8X55 - clé 10	Schraube Radeinstellung M8X55 - Schlüssel 10	Tornillo registro rueda M8X55 - llave 10
3	M006200711	2	Dado esagonale M8	M8 hexagonal nut	Ecrou hexagonal M8	Sechskantmutter	Tuerca hexagonal
4	M2138121	1	Perno antirotazione M8	M8 anti-rotation pin	Pivot antirotation M8	Antirotationsbolzen M8	Perno antirotación M8
5	M23710002010	1	Pattino catena inferiore	Chain lower sliding shoe	Patin de chaîne inférieur	Kettengleitschuh unten	Patín cadena inferior
6	M01000012401	2	Vite M5X16	Screw M5X16	Vis M5X16	Schraube M5X16	Tornillo M5X16
7	M213822140	1	Pattino catena superiore	Chain upper sliding shoe	Patin de chaîne supérieur	Kettengleitschuh oben	Patín cadena superior
8	M01000085104	2	Vite TS M8X16	Flat head screw M8X16	Vis à tête noyée M8X16	Senkkopfschraube M8X16	Tornillo de cabeza M8X16 avellanada
9	M91800005400	2	Dado M6	Nut M6	Dado M6	Mutter M6	Tuerca M6 H
10	M06000010110	1	Perno forcellone	Swing arm spindle	Axe bras oscillant	Zapfen Federbein	Perno horquilla
11	M08000009400	1	Astuccio rullini	Bearing holder	Pochette aiguilles de roulement	Rollenkäfig	Jaula de rodillos
12	M2138301	1	Bussola interna sx	Left inside bushing	Douille interne gauche	Buchse innen li.	Casquillo interno izq.
13	M2138311	1	Distanziale interno sx	Left inside spacer	Entretoise intérieure gch.	Distanzring innen li.	Distanciadore interior izq.
14	M2138391	2	Boccola attacco forcellone	Swing arm coupling bushing	Douille de fixation bras oscillant	Anschlussbuchse Gabel	Casquillo de unión horquilla
15	M2138321	1	Boccola distanziale interno dx	Right inside spacer bushing	Bague entretoise intérieure droite	Buchse Distanzring innen re.	Casquillo distanciadore interior der.
16	M0072001	1	Cuscinetto 22X50X14 2RS1	Bearing 22X50X14 2RS1	Coussinet 22X50X14 2RS1	Lager 22X50X14 2RS1	Cojinete 22X50X14 2RS1
17	M0066233	1	Seeger	Circlip	Circlip	Seeger	Seeger
18	M2138341	1	Distanziale forcellone esterno dx	Swing arm right outside spacer	Entretoise extérieure droite bras oscillant	Distanzring aussen re. Gabel	Distanciadore exterior der. horquilla
19	M2138361	1	Bussola forcellone esterna dx	Swing arm right outside bushing	Douille extérieure droite bras oscillant	Buchse aussen re. Gabel	Casquillo exterior der. horquilla
20	M02000004401	1	Dado flangiato M18X1.5	Flanged nut M18X1.5	Ecrou bridé M18X1.5	Flanschmutter M18X1.5	Tuerca embridada M18X1.5
21	M14500006300	1	Ammortizzatore posteriore	Rear shock-absorber	Amortisseur arrière	Federbein hinten	Amortiguador trasero
22	M01000071104	1	Perno superiore ammortizzatore	Shock-absorber upper pin	Pivot supérieur amortisseur	Bolzen oben Federbein	Perno superior Amortiguador



GRANPASSO
1200

**Forcellone/Ammortizzatore - Swing arm/Shock absorber - Bras oscillant/
Amortisseur - Federbein/Stoßdämpfer - Horquilla/Amortiguador**

015

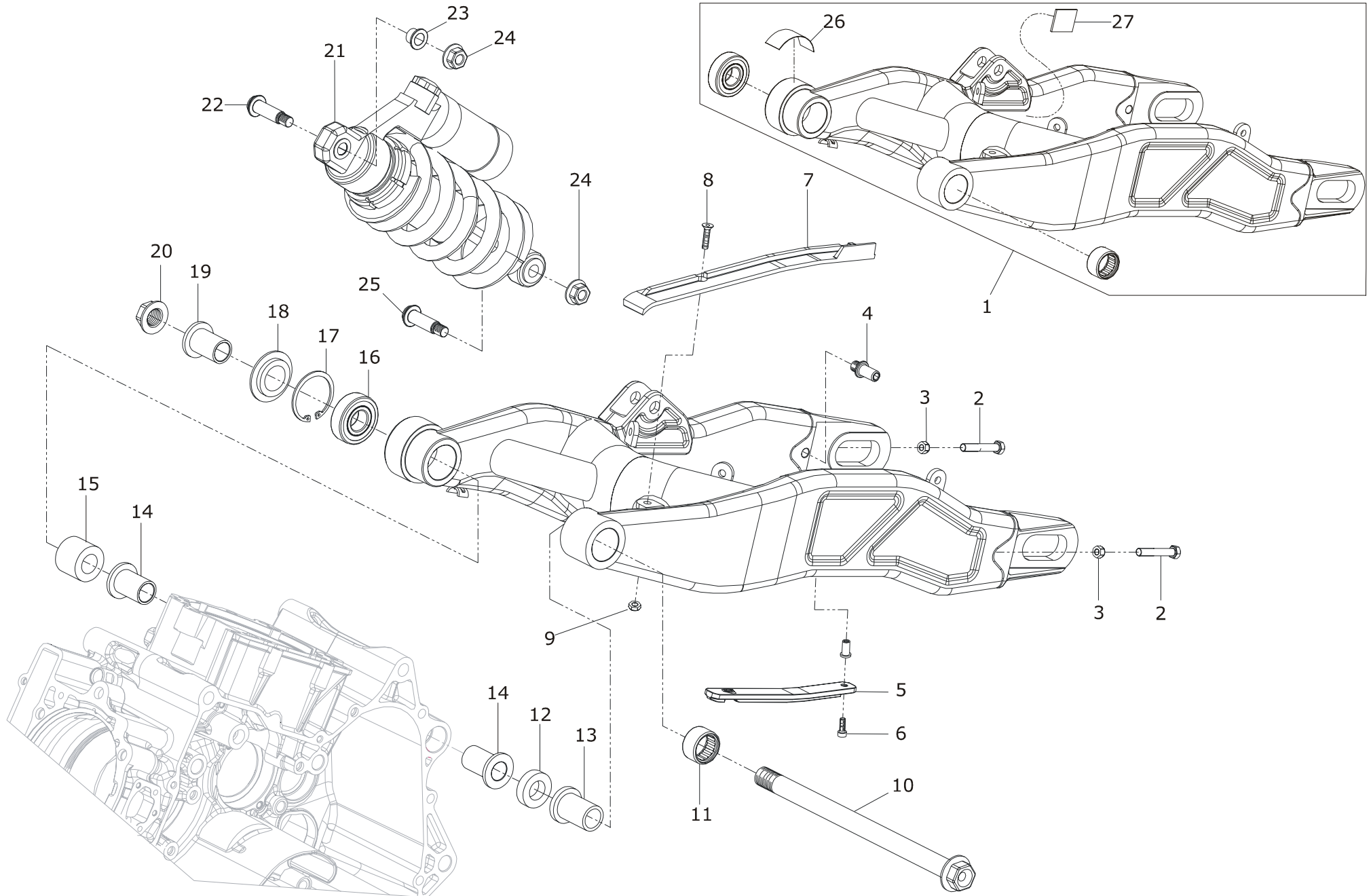

**GRANPASSO**
1200**Forcellone/Ammortizzatore - Swing arm/Shock absorber - Bras oscillant/
Amortisseur - Federbein/Stoßdämpfer - Horquilla/Amortiguador****015**

N°	Cod.	Q.	Descrizione	Description	Description	Beschreibung	Descripción
23	M02200012104	1	Boccola fissaggio ammortizzatore post.	<i>Rear shock-absorber fixing bushing</i>	Bague de fixation amortisseur arrière	<i>Befestigungsbuchse Federbein hinten</i>	Casquillo fijación amortiguador trasero
24	M02000042104	1	Dado M10X1.5 flangiato	<i>Flanged nut M10X1.5</i>	Ecrou bridé M10X1.5	<i>Flanschmutter M10X1.5</i>	Tuerca embridada M10X1.5
25	M2138231	1	Vite perno inferiore ammortizzatore	<i>Screw shock-absorber lower pin screw</i>	Vis pivot inférieur amortisseur	<i>Schraube Bolzen unten Federbein</i>	Tornillo perno inferior amortiguador
26	M26500008200	1	Adesivo di protezione forcellone	<i>Protection adhesive swing arm</i>	Adhésif de protection bras oscillant	<i>Schutzklebestreifen Federbein</i>	Adhesivo de protección horquilla
27	M26500020000	1	Adesivo di protezione	<i>Protection adhesive</i>	Adhésif de protection	<i>Schutzklebestreifen</i>	Adhesivo de protección



GRANPASSO
1200

Cavalletto - Stand - Béquille - Ständer - Caballete

016

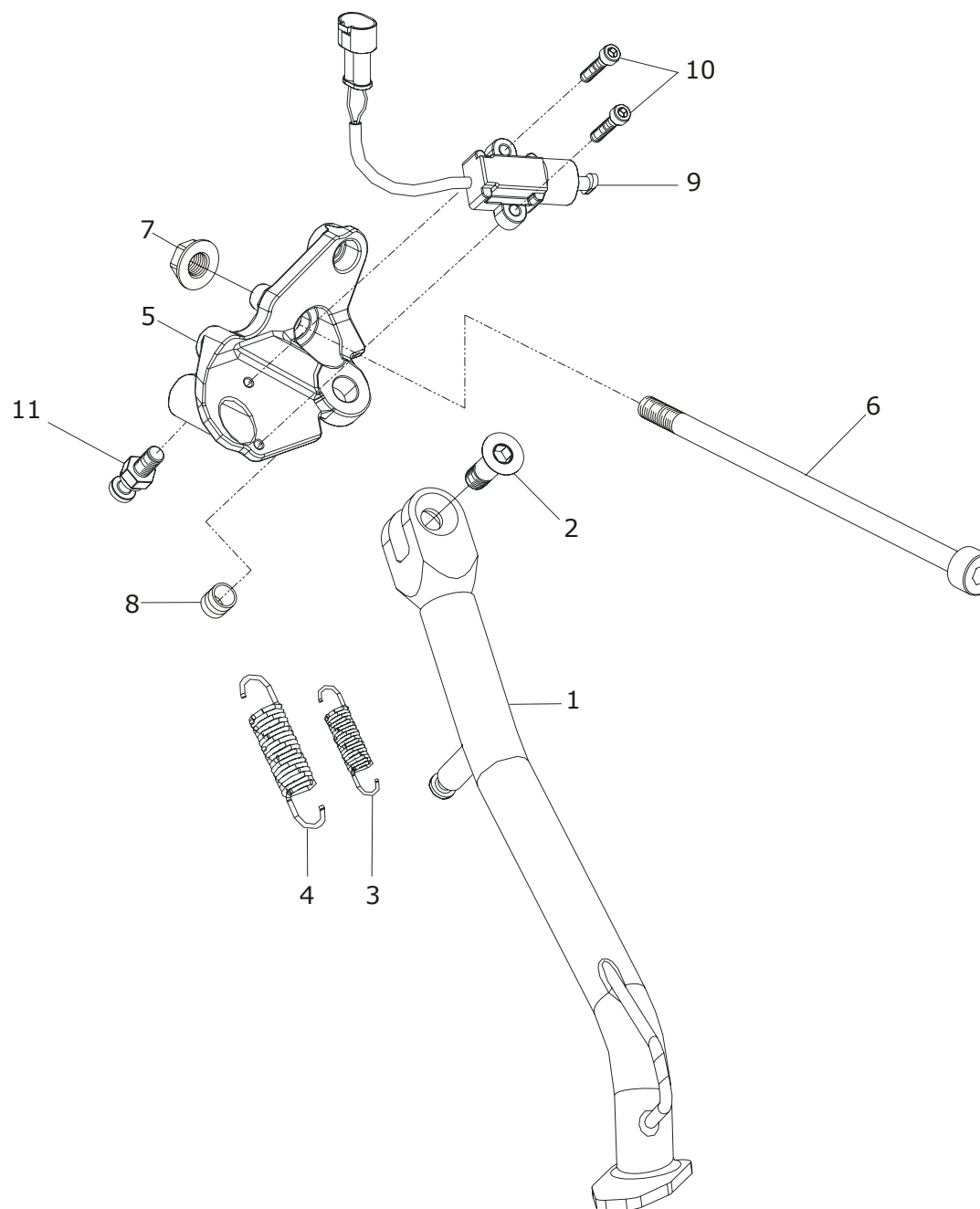



N°	Cod.	Q.	Descrizione	Description	Description	Beschreibung	Descripción
1	M213721140	1	Cavalletto laterale	<i>Side stand</i>	Béquille latérale	<i>Seitenständer</i>	Caballete lateral
2	M01000094105	1	Vite cavalletto laterale	<i>Side stand screw</i>	Vis béquille latérale	<i>Schraube Seitenständer</i>	Tornillo caballete lateral
3	M09120005628	1	Molla interna cavalletto laterale	<i>Side stand inside spring</i>	Ressort intérieur béquille latérale	<i>Innenfeder Seitenständer</i>	Muelle interno caballete lateral
4	M09120004628	1	Molla esterna cavalletto laterale	<i>Side stand outside spring</i>	Ressort extérieur béquille latérale	<i>Außenfeder Seitenständer</i>	Muelle externo caballete lateral
5	M163731140	1	Piastra supporto cavalletto laterale	<i>Side stand supporting. plate</i>	Plaque de support béquille latérale	<i>Halteplatte Seitenständer</i>	Placa soporte caballete lateral
6	M06000031401	1	Perno staffa microfusa superiore cavalletto laterale	<i>Side stand upper microcast bracket pin</i>	Pivot bride micro fondue supérieure béquille latérale	<i>Zapfen oberer präzisionsgegossener Bügel Seitenständer</i>	Perno brida superior fundida de precisión caballete lateral
7	M02000016401	1	Dado flangiato autobloccante M12X1.25	<i>Flanged nut self-locking M12X1.25</i>	Ecrou bridé de sécurité M12X1.25	<i>Selbstsperrende Flanschmutter M12X1.25</i>	Tuerca embridada autobloccante M12X1.25
8	M1637321	1	Boccola per cavalletto laterale	<i>Side stand bushing</i>	Bague béquille latérale	<i>Buchse Seitenständer</i>	Casquillo caballete lateral
9	M30010002400	1	Interruttore cavalletto laterale	<i>Side stand switch</i>	Interrupteur béquille latérale	<i>Schalter Seitenständer</i>	Interruptor caballete lateral
10	M01000035401	2	Vite M5X16	<i>Screw M5X16</i>	Vis M5X16	<i>Schraube M5X16</i>	Tornillo M5X16
11	M06000001111	2	Perno fissaggio molle cavalletto	<i>Thrust arm spring fixing pin</i>	Pivot fixation ressort béquille latérale	<i>Federbefestigungszapfen Seitenständer</i>	Perno fijación muelles caballete lateral

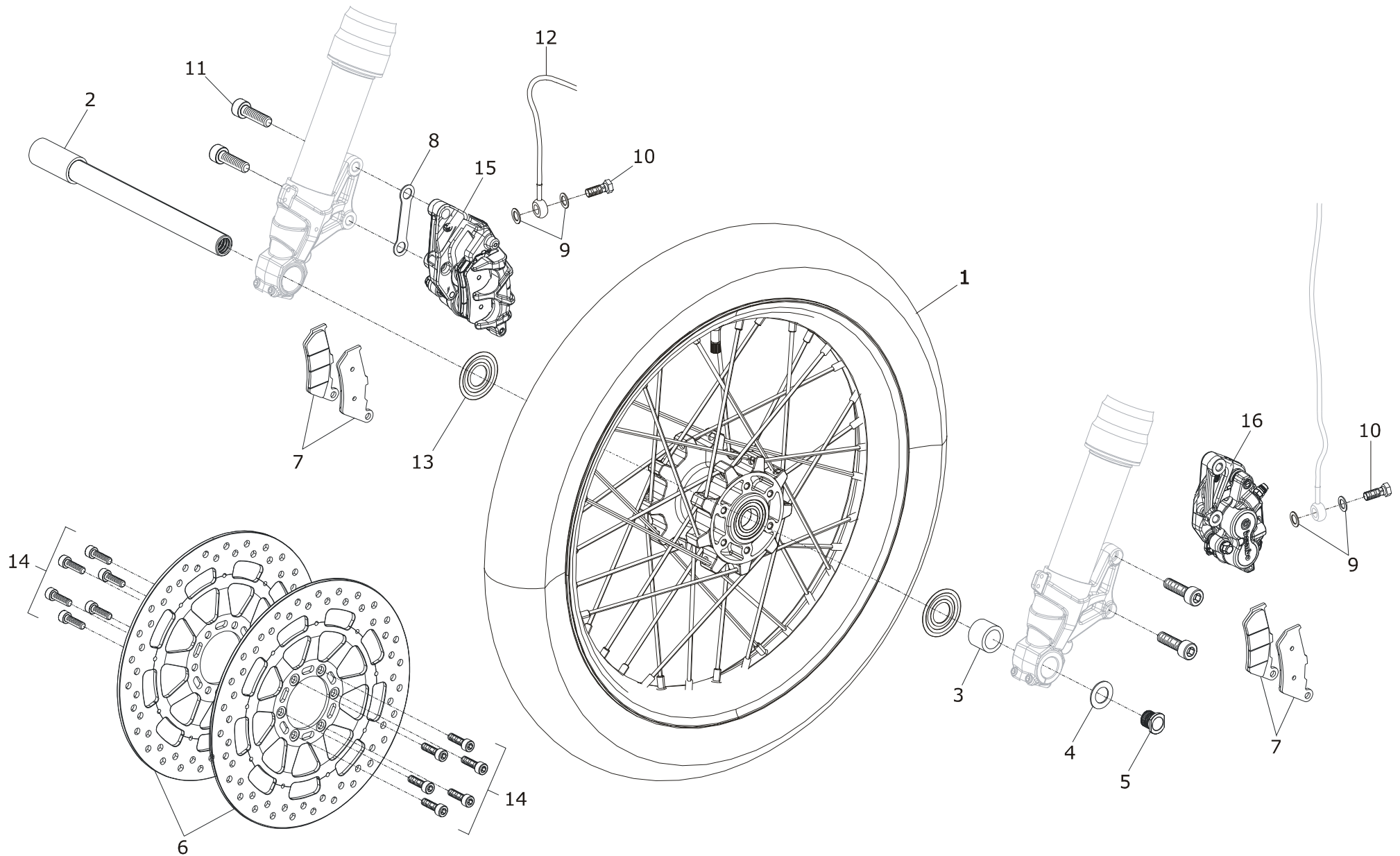

N°	Cod.	Q.	Descrizione	Description	Description	Beschreibung	Descripción
1	R2145001	1	Ruota anteriore completa	<i>Complete front wheel</i>	Roue avant complète	<i>Vorderrad komplett</i>	Rueda delantera completa
2	M06000002111	1	Perno ruota anteriore	<i>Front wheel pin</i>	Pivot roue avant	<i>Zapfen Vorderrad</i>	Perno ruota delantera
3	M2145191	1	Distanziale esterno perno ruota anteriore	<i>Front wheel spindle outside spacer</i>	Entretoise externe pivot roue avant	<i>Distanzscheibe außen Zapfen Vorderrad</i>	Distanciador externo perno ruota delantera
4	M03030010111	1	Rondella perno ruota anteriore	<i>Front wheel spindle washer</i>	Rondelle pivot roue avant	<i>Unterlegscheibe Zapfen Vorderrad</i>	Arandela perno ruota delantera
5	M01010001111	1	Vite perno ruota anteriore	<i>Front wheel spindle screw</i>	Vis pivot roue avant	<i>Schraube Zapfen Vorderrad</i>	Tornillo perno ruota delantera
6	M12000007104	2	Disco freno anteriore	<i>Front brake disc</i>	Disque frein avant	<i>Bremsscheibe Vorder</i>	Disco freno delantero
7	M2140201	2	Coppia pastiglie freno	<i>Pair of brake pads</i>	Jeu de 2 plaquettes de frein	<i>Paar Bremsbacken</i>	Par pastillas de freno
8	M2140211	1	Piastrina pinza freno spessore 1.5/2.0/2.5	<i>Brake caliper plate shim 1.5/2.0/2.5</i>	Plaquettes étriers de frein épaisseur 1.5/2.0/2.5	<i>Plättchen Bremszange Distanzstück 1.5/2.0/2.5</i>	Placa pinza freno espesor 1.5/2.0/2.5
9	M0063001	4	Rondella rame Ø 10X14X1.5	<i>Copper washer Ø 10X14X1.5</i>	Rondelle en cuivre Ø 10X14X1.5	<i>Kupferunterlegscheibe Ø 10X14X1.5</i>	Arandela de cobre Ø 10X14X1.5
10	M0061001	2	Vite forata M10X1	<i>Drilled screw M10X1</i>	Vis percée M10X1	<i>Lochschraube M10X1</i>	Tornillo perforado M10X1
11	M005038110	4	Vite TCEI M10X1.25X35	<i>Screw TCEI M10X1.25X35</i>	Vis TCEI M10X1.25X35	<i>Schraube TCEI M10X1.25X35</i>	Tornillo TCEI M10X1.25X35
12	M2140011	1	Impianto freno anteriore completo	<i>Complete front braking system</i>	Installation frein avant complète	<i>Vorderbremsanlage komplett</i>	Instalación freno delantero completo
13	M09200004000	2	Protezione cuscinetto	<i>Bearing protection</i>	Protection coussinet	<i>Kugellagerschutz</i>	Protección cojinete
14	M01000002401	12	Vite disco freno	<i>Screw brake disc</i>	Vis disque frein	<i>Schraube Bremsscheibe</i>	Tornillo disco freno
15	M2140071	1	Pinza freno anteriore dx	<i>Front right brake caliper</i>	Etrier frein avant dt	<i>Zapfen Bremszange rechts</i>	Pinza freno delantera der.
16	M2140101	1	Pinza freno anteriore sx	<i>Front left brake caliper</i>	Etrier frein avant gche	<i>Zapfen Bremszange links</i>	Pinza freno delantera izq.

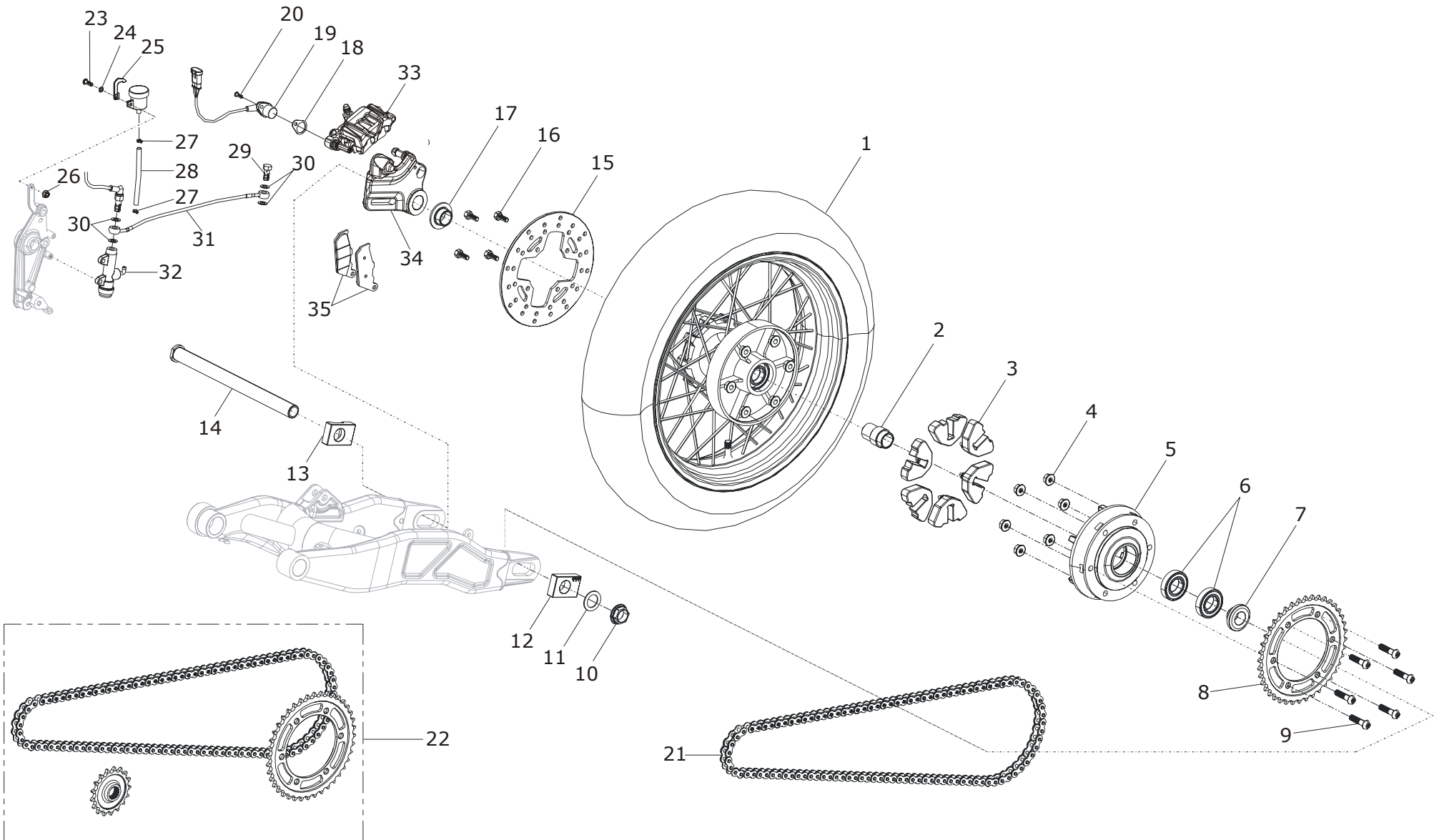



N°	Cod.	Q.	Descrizione	Description	Description	Beschreibung	Descripción
1	M2145101 101	1	Ruota posteriore completa	Complete rear wheel	Roue arrière complète	Hinterrad komplett	Rueda trasera completa
2	M07000013000	1	Distanziale parastrappi	Cush drive damper pad spacer	Entretoise flector	Distanzialscheibe elastische Kupplung	Distanciador juntas amortiguadoras
3	M40100001011	6	Parastrappi in gomma	Rubber cush drive damper pads	Flector en caoutchouc	Elastische Kupplung aus Gummi	Juntas amortiguadoras de goma
4	M02000032401	6	Dado M10 flangiato autobloccante	Self-locking flanged nut M10	Ecrou bridé M10 de sécurité	Selbstsperrende M10 Flanschmutter	Tuerca embridada M10 autobloccante
5	M16200002201	1	Flangia portacorona	Sprocket flange	Bride porte-couronne	Flansch Trägerkranz	Brida portacorona
6	M08000008400	2	Cuscinetto flangia portacorona	Bearing sprocket flange	Coussinet bride porte-couronne	Kugellager Flansch Trägerkranz	Cojinete brida portacorona
7	M2145151	1	Distanziale esterno sx ruota posteriore	Rear wheel outside left spacer	Entretoise externe roue arrière	Distanzscheibe außen links Hinterrad	Distanciador externo izquierdo ruota trasera
8	M16000002105	1	Corona Z 40	Gear Z 40	Couronne Z 40	Kranz Z 40	Corona Z 40
9	M01000068110	6	Vite fissaggio corona TBEI M10X42	Gear fastening button head cap screw M10X42	Vis TBEI M10X42 fixation couronne	Schraube TBEI M10X42 Befestigung Kranz	Tornillo TBEI M10X42 fijación corona
10	M02000001401	1	Dado M25X2 flangiato	Flanged nut M25X2	Ecrou bridé M25X2	Flanschmutter M25X2	Tuerca embridada M25X2
11	M2145071	1	Rondella distanziale ruota posteriore	Rear wheel washer spacer	Rondelle entretoise roue arrière	Unterlegscheibe Distanzscheibe Hinterrad	Arandela distanciador ruota trasera
12	M10400002103	1	Pattino regolazione catena sx	Chain left adjusting sliding shoe	Patin de réglage chaîne gche	Einstellung Kettengleitschuh links	Regulación patín cadena izq.
13	M10400001103	1	Pattino regolazione catena dx	Chain left adjusting sliding shoe	Patin de réglage chaîne dte	Einstellung Kettengleitschuh rechts	Regulación patín cadena der.
14	M06000008111	1	Perno ruota posteriore	Rear wheel spindle	Pivot roue arrière	Zapfen Hinterrad	Perno ruota trasera
15	M12000008400	1	Disco freno posteriore Ø 255 mm	Rear brake disc Ø 255 mm	Disque frein arrière Ø 255 mm	Hinterradbremsscheibe Ø 255 mm	Disco freno trasero Ø 255 mm
16	M01000055401	4	Vite TE M8X20	Screw TE M8X20	Vis TE M8X20	Schraube TE M8X20	Tornillo TE M8X20
17	M07000011112	1	Distanziale esterno perno ruota posteriore	Rear wheel spindle outside spacer	Entretoise externe pivot roue arrière	Distanzscheibe außen Zapfen Hinterrad	Distanciador externo perno ruota trasera
18	M09200002012	3	Lamierino taratura sensore velocità	Speed sensor setting plate	Epaisseur capteur de vitesse	Dickenlehre Geschwindigkeitssensor	Galga espesor sensor velocidad
19	M30010001400	1	Sensore velocità	Speed sensor	Capteur de vitesse	Geschwindigkeitssensor	Sensor velocidad
20	M01000005401	1	Vite M6X16	Screw M6X16	Vis M6X16	Schraube M6X16	Tornillo M6X16
21	M16300003000	1	Catena	Chain	Chaîne	Kette	Cadena
22	M16300005300	1	Kit trasmissione finale	Final transmission kit	Kit transmission finale	Endantrieb-Kit	Juego transmisión final

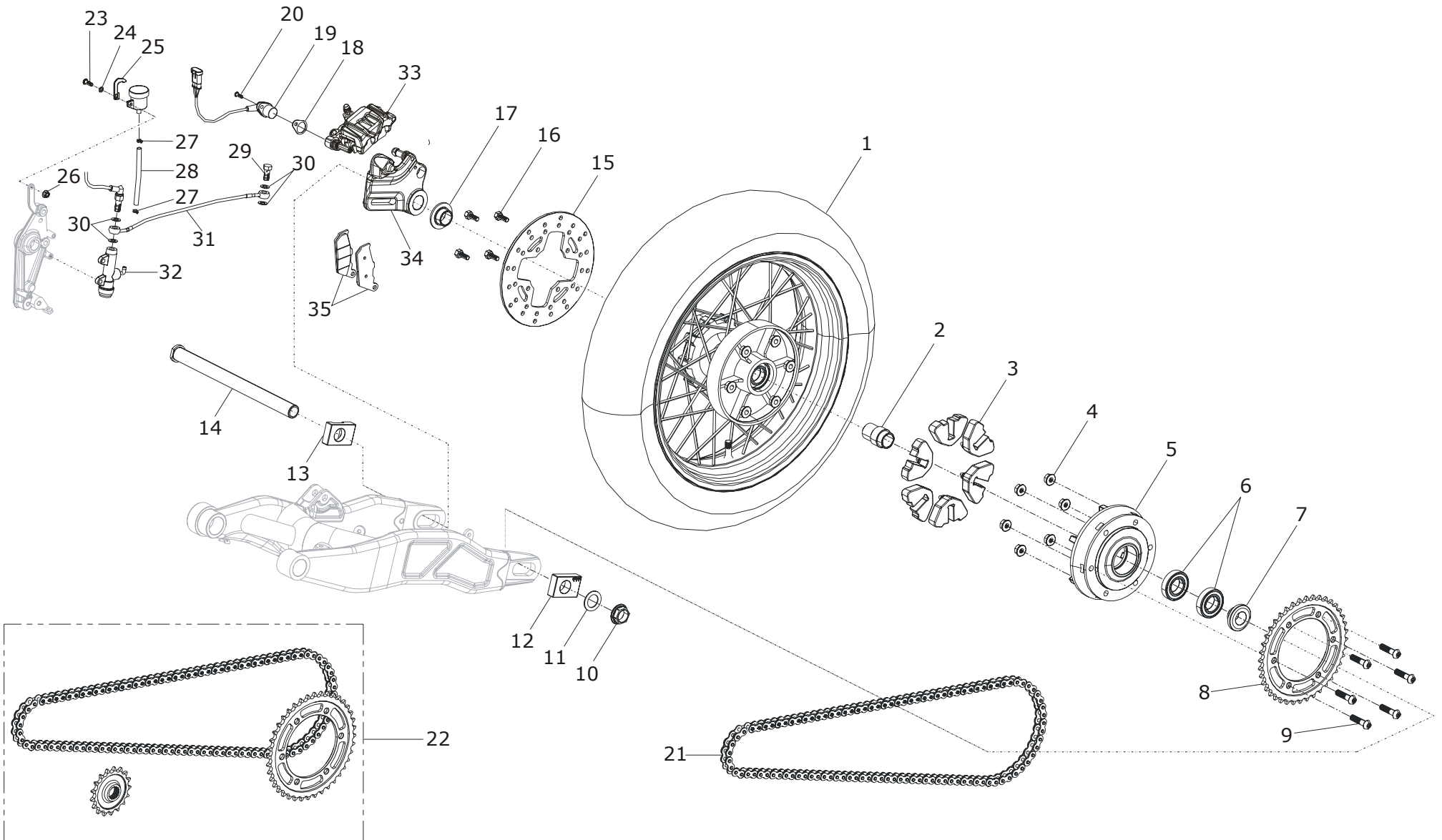



N°	Cod.	Q.	Descrizione	Description	Description	Beschreibung	Descripción
23	M01000049401	1	Vite M5X20	<i>Screw M5X20</i>	Vis M5X20	<i>Schraube M5X20</i>	Tornillo M5X20
24	M03000022110	1	Rondella Ø5.5X10X1.5	<i>Washer Ø5.5X10X1.5</i>	Rondelle Ø5.5X10X1.5	<i>Unterlegscheibe Ø5.5X10X1.5</i>	Arandela Ø5.5X10X1.5
25	M2141371	1	Fermo tappo serbatoio	<i>Fuel filler cap stop ring</i>	Capuchon d'arrêt de réservoir	<i>Sicherung Tankdeckel</i>	Retén tapón tanque
26	M02000008401	1	Dado M5 flangiato autobloccante	<i>Self-locking flanged nut M5</i>	Ecrou bridé M5 de sécurité	<i>Selbstsperrende M5 Flanschmutter</i>	Tuerca embridada M5 autoblocante
27	M007800112	2	Clip stringitubo	<i>Hose clamp</i>	Clip serre-tube	<i>Schlauchklemme</i>	Clip de apriete tubo
28	M0081001	1	Tubo L.0,160	<i>Pipe L.0,160</i>	Tube L.0,160	<i>Schlauch L.0,160</i>	Tubo L.0,160
29	M0061001	1	Vite forata M10X1	<i>Drilled screw M10X1</i>	Vis percée M10X1	<i>Lochschrabe M10X1</i>	Tornillo perforado M10X1
30	M0063001	4	Rondella rame Ø10X14X1.5	<i>Copper washer Ø10X14X1.5</i>	Rondelle en cuivre Ø10X14X1.5	<i>Kupferunterlegscheibe Ø10X14X1.5</i>	Arandela de cobre Ø10X14X1.5
31	M2140151	1	Tubo freno	<i>Brake cable</i>	Tube frein	<i>Bremsschlauch</i>	Tubo freno
32	M60100011302	1	Pompa freno	<i>Front radial brake</i>	Pompe frein avant	<i>Radialpumpe</i>	Bomba radial de freno
33	M2140181	1	Pinza freno posteriore	<i>Rear brake caliper</i>	Etrier frein arrière	<i>Bremszange hinten</i>	Pinza freno trasera
34	M2140191	1	Supporto pinza freno	<i>Brake caliper support</i>	Support étrier de frein	<i>Bremszangen Halterung</i>	Soporte pinza freno
35	M13000015000	1	Pastiglie freno posteriore	<i>Rear brakes pads</i>	Plaquettes de frein arrière	<i>Bremsscheiben hinten</i>	Pastillas freno trasera

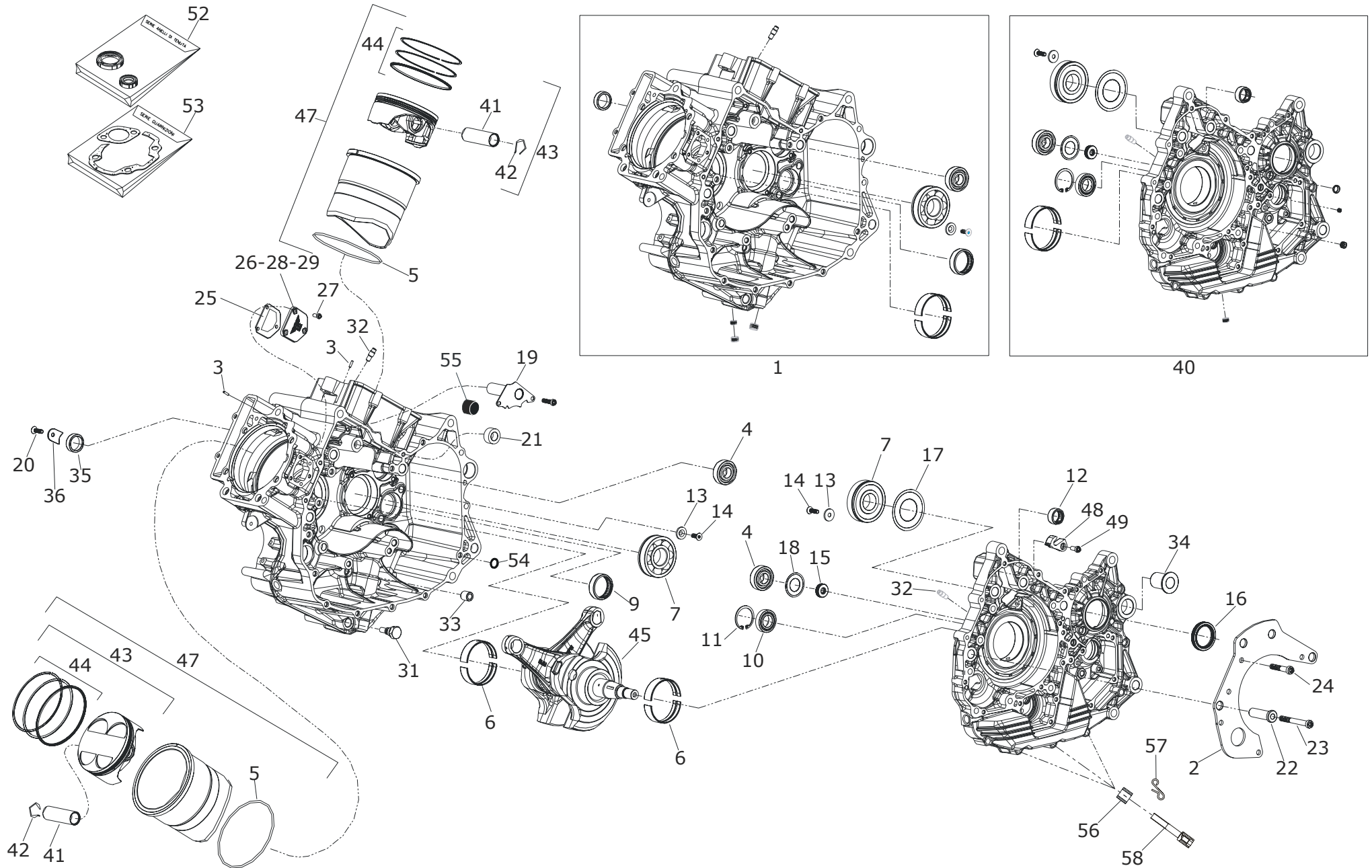

**GRANPASSO**
1200**Carter e imbiellaggio - Casing and connecting rod - Carter et vilebrequin
Schutzverkleidung - Carter y acoplamiento de bielas****019**

N°	Cod.	Q.	Descrizione	Description	Description	Beschreibung	Descripción
1	M95500003400	1	Semicarter centrale completo	Complete central engine casing	Demi-carter central complet	Mittlere Halbschale komplett	Semicárter central completo
2	M1610021	1	Staffa di rinforzo	Stiffening bracket	Étrier de renforcement	Stützbügel	Estribo de refuerzo
3	M95100003400	2	Rullo 3x11,8	Roller 3x11.8	Rouleau 3x11,8	Rolle 3x11,8	Rodillo 3x11,8
4	M91700001400	1	Cusc. Ø 20x47x14 6204-2rs1/c4	Bearing Ø 20x47x14 6204-2rs1/c4	Roulement Ø 20x47x14 6204-2rs1/c4	Lager Ø 20x47x14 6204-2rs1/c4	Cojín Ø 20x47x14 6204-2rs1/c4
5	M90400001400	2	Anello O-Ring Ø 116x3 viton	O-ring Ø 116x3 viton	Joint torique Ø 116x3 viton	O-Ring Ø 116x3 Viton	Anillo O-Ring Ø 116x3 viton
6	M95700001400	4	Bronzina di banco blu	Blue workbench bushing	Coussinet de banc bleu	Lagerschale blau	Cojinete de bancada azul
6	M95700002400	4	Bronzina di banco rosso	Red workbench bushing	Coussinet de banc rouge	Lagerschale rot	Cojinete de bancada rojo
7	M91700005400	2	Cusc. Ø 28x68x17	Bearing Ø 28x68x17	Roulement Ø 28x68x17	Lager Ø 28x68x17	Cojin. Ø 28x68x17
9	M91700007400	1	Gabbia a rullini 35x42x12	Roller bearing cage 35x42x12	Cage de roulement 35x42x12	Rollenkäfig 35x42x12	Cojinete de rodillos 35x42x12
10	M91700003400	1	Cuscinetto Ø 20x37x9	Bearing Ø 20x37x9	Roulement Ø 20x37x9	Lager Ø 20x37x9	Cojinete Ø 20x37x9
11	M90500004400	1	Anello seeger Ø 37	Circlip Ø 37	Circlip Ø 37	Seegerring Ø 37	Anillo seeger Ø 37
12	M91700008400	1	Gabbia 20x26x12	Cage 20x26x12	Cage 20x26x12	Käfig 20x26x12	Cojinete 20x26x12
13	M95000015400	4	Ritenuta cuscinetto	Bearing retainer	Retenue roulement	Lagerrückhalt	Retén cojinete
14	M97600030400	4	Vite M6x14	Screw M6x14	Vis M6x14	Schraube M6x14	Tornillo M6x14
15	M90300001400	1	Anello di tenuta Ø 8-22-7 viton	Seal ring Ø 8-22-7 viton	Bague d'étanchéité Ø 8-22-7 viton	Dichtring Ø 8-22-7 Viton	Anillo de estanqueidad Ø 8-22-7 viton
16	M90300002400	1	Anello di tenuta Ø 35-47-7 viton	Seal ring Ø 35-47-7 viton	Bague d'étanchéité Ø 35-47-7 viton	Dichtring Ø 35-47-7 Viton	Anillo de estanqueidad Ø 35-47-7 viton
17	M96800001400	1	Tenuta per cuscinetto	Bearing seal	Joint pour roulement	Lagerdichtung	Sello para cojinete
18	M96800002400	1	Tenuta per cuscinetto	Bearing seal	Joint pour roulement	Lagerdichtung	Sello para cojinete
19	M1610041	1	Coperchio blow-by	Blow-by cover guard	Couvercle blow-by	Blow-by-Abdeckung	Tapa blow-by
20	M97600016400	2	Vite Torx M6x14	Torx screw M6x14	Vis Torx M6x14	Torx-Schraube M6x14	Tornillo Torx M6x14
21	M92000002400	1	Distanziale chiusura carter	Cover guard closing shim	Entretoise fermeture carter	Distanzialscheibe Schalenverschluss	Distanciador cierre carter
22	M1610031	4	Bussola riferimento carter	Cover guard reference blow-by	Bague repère carter	Angleichbuchse Schutzverkleidung	Casquillo referencia carter
23	M97600028400	6	Vite Torx M8x70	Torx screw M8x70	Vis Torx M8x70	Torx-Schraube M8x70	Tornillo Torx M8x70
24	M97600027400	10	Vite Torx M8x45	Torx screw M8x45	Vis Torx M8x45	Torx-Schraube M8x45	Tornillo Torx M8x45
25	M92900003400	2	Guarnizione coperchio laterale	Side cover guard gasket	Joint couvercle latérale	Dichtung Seitenabdeckung	Junta tapa laterale
26	M91500005400	2	Coperchio laterale	Side cover guard	Couvercle latéral	Seitenabdeckung	Tapa laterale
27	M97600014400	6	Vite Torx M5x12	Torx screw M5x12	Vis Torx M5x12	Torx-Schraube M5x12	Tornillo Torx M5x12
28	M141001153	2	Coperchio lat. cilindro nero + serigrafia rossa	Cylinder side cover black + red serigraphy	Couvercle lat. cylindre noire + sérigraphie rouge	Seitenabdeckung Zylinderseite schwarz + rote Grafik	Tapa lateral cilindro negro + gráfica roja
29	M141001152	2	Coperchio lat. cilindro nero + serigrafia bianca	Cylinder side cover black+ white serigraphy	Couvercle lat. cylindre noire + sérigraphie blanche	Seitenabdeckung Zylinderseite schwarz + weisse Grafik	Tapa lateral cilindro negro + gráfica blanca

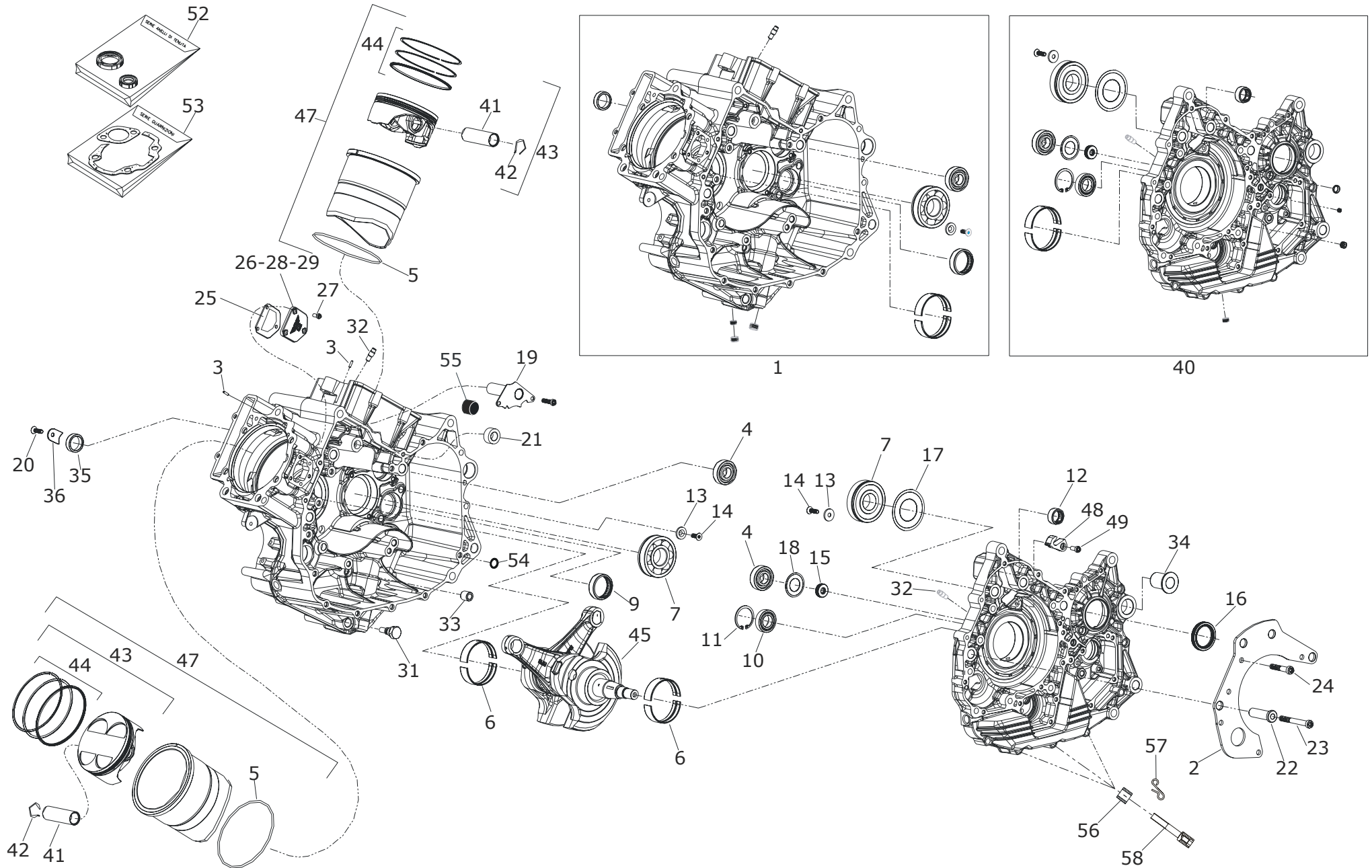

N°	Cod.	Q.	Descrizione	Description	Description	Beschreibung	Descripción
31	M96600004400	1	Tappo magnetico	<i>Magnetic plug</i>	Bouchon magnétique	<i>Magnetdeckel</i>	Tapón magnético
32	M96400001400	2	Spruzzatore olio	<i>Oil spray nozzle</i>	Bec pulvérisateur d'huile	<i>Ölspritzer</i>	Rociador aceite
33	M94700004400	1	Raccordo mandata olio	<i>Oil feed connector</i>	Raccord refoulement huile	<i>Anschlussstück Öleinlauf</i>	Racor inyección aceite
34	M90900001400	2	Boccola attacco forcellone	<i>Swing arm coupling bushing</i>	Bague raccord bras oscillant	<i>Anschlussbuchse Federbein</i>	Casquillo enganche basculante
35	M91700006400	1	Cuscinetto a strisciamento	<i>Friction bearing</i>	Palier-glisseur	<i>Reibelager</i>	Cojinete de rosa
36	M94200006400	1	Piastrina di fermo	<i>Stop plate</i>	Plaque d'arrêt	<i>Halteplättchen</i>	Plaqueta de retén
40	R141001040	1	Semicarter volano completo, nero	<i>Complete flywheel engine housing, black</i>	Semicarter volant complet, noir	<i>Halbschale Schwungrad komplett, schwarz</i>	Semicarter volante completo, negro
41	M96300001400	2	Spinotto	<i>Piston pin</i>	Axe	<i>Stift</i>	Clavija
42	M90500001400	4	Seeger spinotto	<i>Piston pin circlip</i>	Circlip d'axe	<i>Seeger Stift</i>	Seeger clavija
43	R2112020	2	Pistone completo	<i>Complete piston</i>	Piston complet	<i>Kolben komplett</i>	Pistón completo
44	M96000001400	2	Serie segmenti	<i>Set of piston rings</i>	Jeu de segments	<i>Segmentsatz</i>	Serie segmentos
45	M90100005400	1	Albero motore completo	<i>Complete engine shaft</i>	Arbre moteur complet	<i>Motorwelle komplett</i>	Eje motor completo
47	R2112010	2	Canna cilindro + pistone	<i>Cylinder + piston rod</i>	Fût de cylindre + piston	<i>Zylinder- und Kolbenschaft</i>	Leva cilindro + pistón
48	M95400001400	1	Sede pattino fisso	<i>Fixed shoe housing</i>	Logement patin fixe	<i>Festes Gleitlager</i>	Asiento patín fijo
49	M97600016400	1	Vite torx M6X14	<i>Torx screw M6X14</i>	Vis torx M6X14	<i>Torx-Schraube M6X14</i>	Tornillo torx M6X14
52	M95900001400	1	Serie anelli	<i>Set of rings</i>	Jeu de bagues	<i>Satz Ringe</i>	Serie anillos
53	M95900002400	1	Serie guarnizioni carter	<i>Cover guard set of gaskets</i>	Jeu de joints pour carter	<i>Satz Schalendichtungen</i>	Serie junta cárter
54	M90400014400	1	Anello OR 11X2	<i>O-ring 11X2</i>	Joint torique 11X2	<i>O-Ring 11X2</i>	Anillo OR 11X2
55	M1610051	2	Gommino ritegno coperchio blow-by	<i>Blow-by retaining ring</i>	Joint d'étanchéité en caoutchouc couvercle blow-by	<i>Haltering Blow-By-Deckel</i>	Anillo de retención tapa blow-by
56	M2142591	3	Distanziale sinistro per protezione coppa	<i>Sump protection left spacer</i>	Entretoise gche pour protection moteur	<i>Distanzstück links für Schutz Ölbehälter</i>	Distanciadador izq. para protección depósito de aceite
57	M2343021	5	Distanziale per molla	<i>Spring spacer</i>	Entretoise pour ressort	<i>Distanzstück für Feder</i>	Distanciadador para muelle
58	M2343011	2	Molletta ferma cavo	<i>Cable stop clip</i>	Pince serre-câble	<i>Kabelhaltefeder</i>	Muelle de sujeción del cable

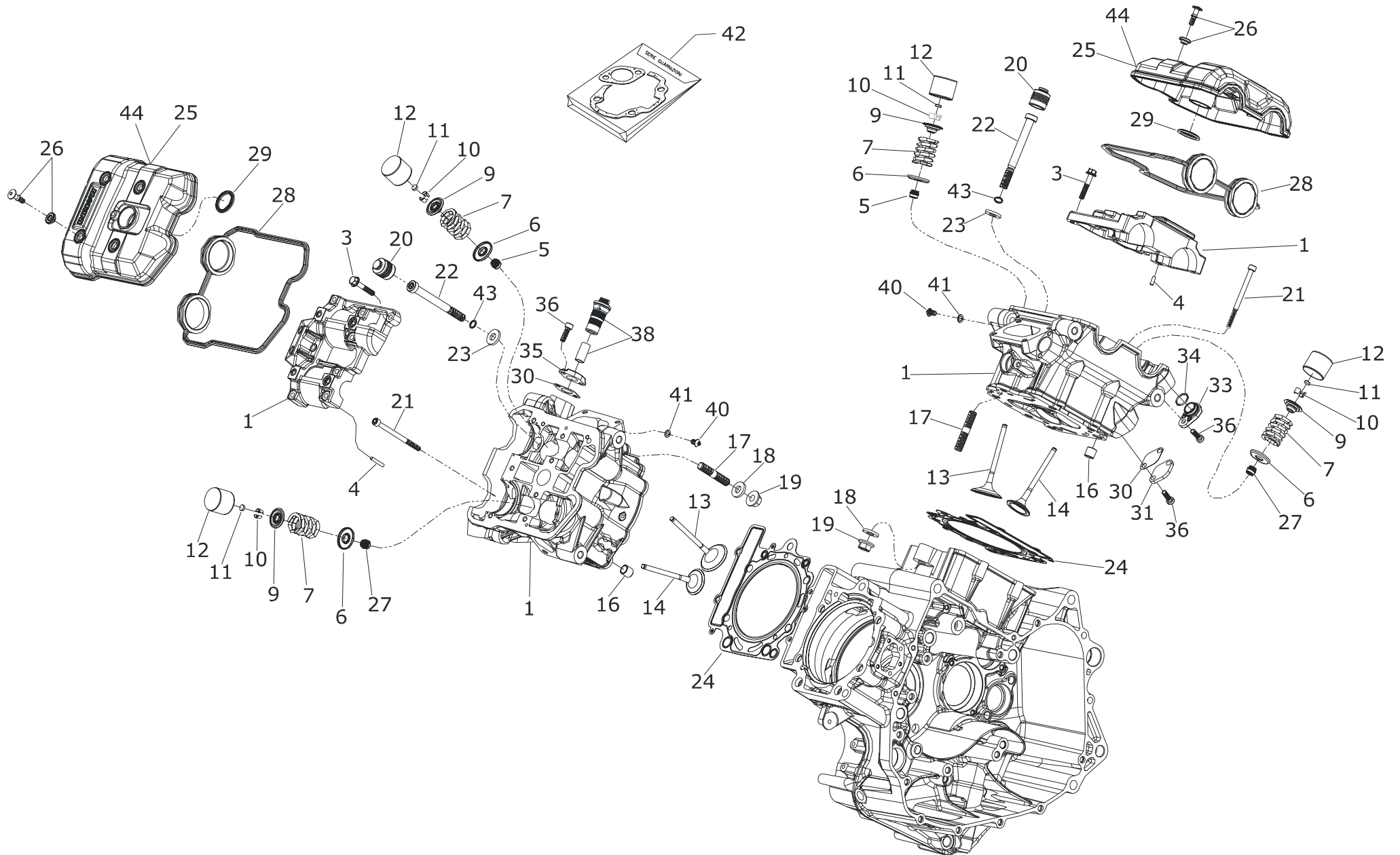



N°	Cod.	Q.	Descrizione	Description	Description	Beschreibung	Descripción
1	M97000003400	2	Testa completa di sedi e guide	<i>Complete head and guides</i>	Culasse complète de logements et guidages	<i>Kopfstück komplett mit Lagern und Schienen</i>	Cabezal con asientos y guías
3	M97600012400	16	Vite M6X35 classe 10.9	<i>Screw M6X35 class 10.9</i>	Vis M6X35 classe 10.9	<i>Schraube M6X35 Klasse 10.9</i>	Tornillo M6X35 clase 10.9
4	M95100001400	4	Rullino 4X13,8	<i>Roller 4X13.8</i>	Aiguille de roul. 4X13,8	<i>Rolle 4X13,8</i>	Rodillo 4X13,8
5	M90300008400	4	Anello raschiavalvole	<i>Valve scraper ring</i>	Joint de la tige de soupape	<i>Ventilschaber Ring</i>	Anillo rasca válvulas
6	M95300001400	8	Scodellino molla inf.	<i>Lower spring cap</i>	Cuvette ressort inf.	<i>Federteller unten</i>	Cazoleta muelle inferior
7	M93300005400	8	Molla valvola	<i>Valvle spring</i>	Ressort soupape	<i>Ventilfeder</i>	Muelle válvula
9	M95300002400	8	Scodellino molla sup.	<i>Upper spring cap</i>	Cuvette ressort sup.	<i>Federteller oben</i>	Cazoleta muelle superior
10	M95600001400	16	Semiconi valvola	<i>Cotter valve</i>	Demi-cônes soupape	<i>Halbkegel ventil</i>	Semiconos válvula
11	M94000026400	8	Pastiglia regolazione sp.1.900	<i>Shim adjusting pad 1.900</i>	Plaquette réglage ép.1.900	<i>Reglerplatte H 1.900</i>	Pastilla regulación esp.1.900
11	M94000027400	8	Pastiglia regolazione sp.1.925	<i>Shim adjusting pad 1.925</i>	Plaquette réglage ép.1.925	<i>Reglerplatte H 1.925</i>	Pastilla regulación esp.1.925
11	M94000028400	8	Pastiglia regolazione sp.1.950	<i>Shim adjusting pad 1.950</i>	Plaquette réglage ép.1.950	<i>Reglerplatte H 1.950</i>	Pastilla regulación esp.1.950
11	M94000029400	8	Pastiglia regolazione sp.1.975	<i>Shim adjusting pad 1.975</i>	Plaquette réglage ép.1.975	<i>Reglerplatte H .1.975</i>	Pastilla regulación esp.1.975
11	M94000001400	8	Pastiglia regolazione sp.2.000	<i>Shim adjusting pad 2.000</i>	Plaquette réglage ép.2.000	<i>Reglerplatte H 2.000</i>	Pastilla regulación esp.2.000
11	M94000002400	8	Pastiglia regolazione sp.2.025	<i>Shim adjusting pad 2.025</i>	Plaquette réglage ép.2.025	<i>Reglerplatte H 2.025</i>	Pastilla regulación esp.2.025
11	M94000003400	8	Pastiglia regolazione sp.2.050	<i>Shim adjusting pad 2.050</i>	Plaquette réglage ép.2.050	<i>Reglerplatte H 2.050</i>	Pastilla regulación esp.2.050
11	M94000004400	8	Pastiglia regolazione sp.2.075	<i>Shim adjusting pad 2.075</i>	Plaquette réglage ép. 2.075	<i>Reglerplatte H 2.075</i>	Pastilla regulación esp.2.075
11	M94000005400	8	Pastiglia regolazione sp.2.100	<i>Shim adjusting pad 2.100</i>	Plaquette réglage ép. 2.100	<i>Reglerplatte H 2.100</i>	Pastilla regulación esp.2.100
11	M94000006400	8	Pastiglia regolazione sp.2.125	<i>Shim adjusting pad 2.125</i>	Plaquette réglage ép. 2.125	<i>Reglerplatte H 2.125</i>	Pastilla regulación esp.2.125
11	M94000007400	8	Pastiglia regolazione sp.2.150	<i>Shim adjusting pad 2.150</i>	Plaquette réglage ép. 2.150	<i>Reglerplatte H 2.150</i>	Pastilla regulación esp.2.150
11	M94000008400	8	Pastiglia regolazione sp.2.175	<i>Shim adjusting pad 2.175</i>	Plaquette réglage ép. 2.175	<i>Reglerplatte H 2.175</i>	Pastilla regulación esp.2.175
11	M94000009400	8	Pastiglia regolazione sp.2.200	<i>Shim adjusting pad 2.200</i>	Plaquette réglage ép. 2.200	<i>Reglerplatte H 2.200</i>	Pastilla regulación esp.2.200
11	M94000010400	8	Pastiglia regolazione sp.2.225	<i>Shim adjusting pad 2.225</i>	Plaquette réglage ép. 2.225	<i>Reglerplatte H 2.225</i>	Pastilla regulación esp.2.225
11	M94000011400	8	Pastiglia regolazione sp.2.250	<i>Shim adjusting pad 2.250</i>	Plaquette réglage ép. 2.250	<i>Reglerplatte H 2.250</i>	Pastilla regulación esp.2.250

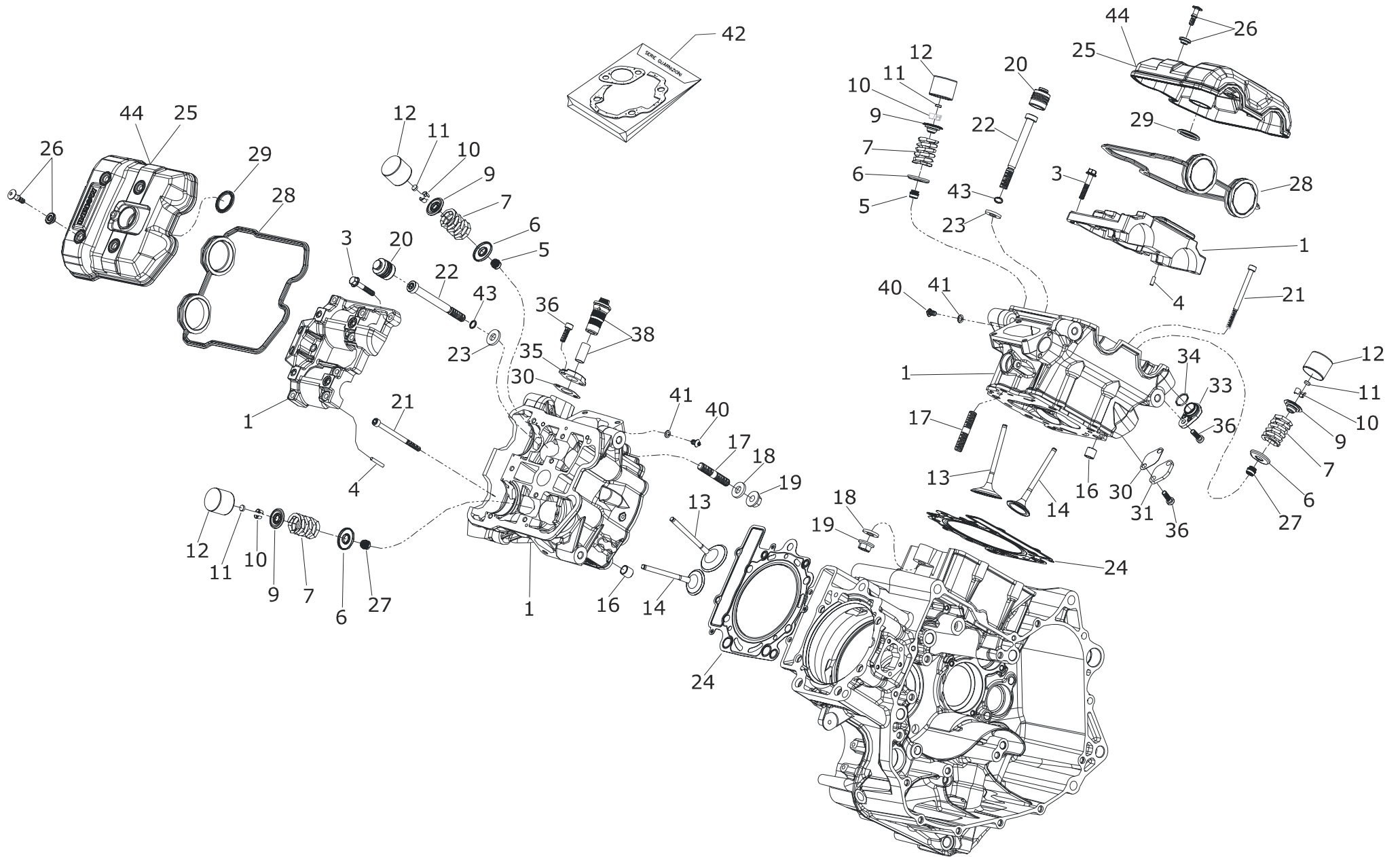



N°	Cod.	Q.	Descrizione	Description	Description	Beschreibung	Descripción
11	M94000012400	8	Pastiglia regolazione sp.2.275	<i>Shim adjusting pad 2.275</i>	Plaquette réglage ép. 2.275	<i>Reglerplatte H 2.275</i>	Pastilla regulación esp.2.275
11	M94000013400	8	Pastiglia reg. sp.2.300	<i>Shim adjusting pad 2.300</i>	Plaquette réglage ép. 2.300	<i>Reglerplatte H 2.300</i>	Pastilla regulación esp.2.300
11	M94000014400	8	Pastiglia regolazione sp.2.325	<i>Shim adjusting pad 2.325</i>	Plaquette réglage ép. 2.325	<i>Reglerplatte H 2.325</i>	Pastilla regulación esp.2.325
11	M94000015400	8	Pastiglia regolazione sp.2.350	<i>Shim adjusting pad 2.350</i>	Plaquette réglage ép. 2.350	<i>Reglerplatte H 2.350</i>	Pastilla regulación esp.2.350
11	M94000016400	8	Pastiglia regolazione sp.2.375	<i>Shim adjusting pad 2.375</i>	Plaquette réglage ép. 2.375	<i>Reglerplatte H 2.375</i>	Pastilla regulación esp.2.375
11	M94000017400	8	Pastiglia regolazione sp.2.400	<i>Shim adjusting pad 2.400</i>	Plaquette réglage ép. 2.400	<i>Reglerplatte H 2.400</i>	Pastilla regulación esp.2.400
11	M94000018400	8	Pastiglia regolazione sp.2.425	<i>Shim adjusting pad 2.425</i>	Plaquette réglage ép. 2.425	<i>Reglerplatte H 2.425</i>	Pastilla regulación esp.2.425
11	M94000019400	8	Pastiglia regolazione sp.2.450	<i>Shim adjusting pad 2.450</i>	Plaquette réglage ép. 2.450	<i>Reglerplatte H 2.450</i>	Pastilla regulación esp.2.450
11	M94000020400	8	Pastiglia regolazione sp.2.475	<i>Shim adjusting pad 2.475</i>	Plaquette réglage ép. 2.475	<i>Reglerplatte H 2.475</i>	Pastilla regulación esp.2.475
11	M94000021400	8	Pastiglia regolazione sp.2.500	<i>Shim adjusting pad 2.500</i>	Plaquette réglage ép. 2.500	<i>Reglerplatte H 2.500</i>	Pastilla regulación esp.2.500
11	M94000022400	8	Pastiglia regolazione sp.2.525	<i>Shim adjusting pad 2.525</i>	Plaquette réglage sp.2.525	<i>Reglerplatte H 2.525</i>	Pastilla regulación esp.2.525
11	M94000023400	8	Pastiglia regolazione sp.2.550	<i>Shim adjusting pad 2.550</i>	Plaquette réglage ép. 2.550	<i>Reglerplatte H 2.550</i>	Pastilla regulación esp.2.550
11	M94000024400	8	Pastiglia regolazione sp.2.575	<i>Shim adjusting pad 2.575</i>	Plaquette réglage ép. 2.575	<i>Reglerplatte H 2.575</i>	Pastilla regulación esp.2.575
11	M94000025400	8	Pastiglia regolazione sp.2.600	<i>Shim adjusting pad 2.600</i>	Plaquette réglage ép. 2.600	<i>Reglerplatte H 2.600</i>	Pastilla regulación esp.2.600
11	M94000030400	8	Pastiglia regolazione sp.2.625	<i>Shim adjusting pad 2.625</i>	Plaquette réglage ép. 2.625	<i>Reglerplatte H 2.625</i>	Pastilla regulación esp.2.625
11	M94000031400	8	Pastiglia regolazione sp.2.650	<i>Shim adjusting pad 2.650</i>	Plaquette réglage ép. 2.650	<i>Reglerplatte H 2.650</i>	Pastilla regulación esp.2.650
11	M94000032400	8	Pastiglia regolazione sp.2.675	<i>Shim adjusting pad 2.675</i>	Plaquette réglage ép. 2.675	<i>Reglerplatte H 2.675</i>	Pastilla regulación esp.2.675
11	M94000033400	8	Pastiglia regolazione sp.2.700	<i>Shim adjusting pad 2.700</i>	Plaquette réglage ép. 2.700	<i>Reglerplatte H 2.700</i>	Pastilla regulación esp.2.700

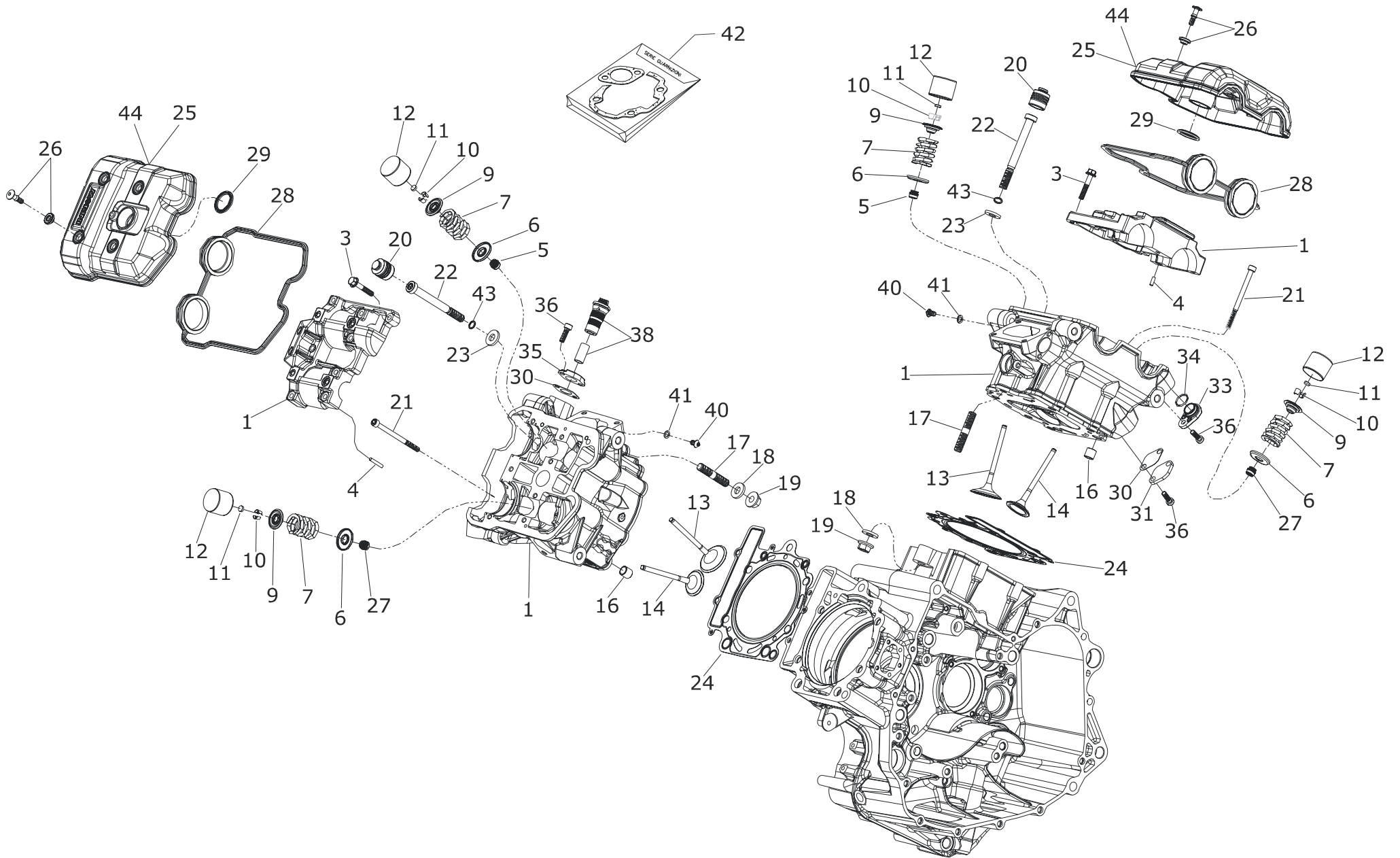

N°	Cod.	Q.	Descrizione	Description	Description	Beschreibung	Descripción
12	M90700001400	8	Bicchierino Ø 32	<i>Bowl Ø 32</i>	Cloche Ø 32	<i>Glocke Ø 32</i>	Vaso Ø 32
13	M97400004400	4	Valvola aspirazione	<i>Intake valve</i>	Soupape d'aspiration	<i>Saugventil</i>	Válvula aspiración
14	M97400005400	4	Valvola scarico	<i>Bleed valve</i>	Soupape d'échappement	<i>Ablassventil</i>	Válvula descarga
16	M96100004400	4	Spina riferimento testa cilindro	<i>Head reference pin</i>	Goupille référence tête cylindre	<i>Ausrichtdorn Zylinderkopf</i>	Clavija referencia culata cilindro
17	M94600002400	2	Prigioniero testa cilindro	<i>Head stud bolt</i>	Goujon tête cylindre	<i>Abdichthülse Zylinderkopf</i>	Tornillo prigionero cabeza cilindro
18	M92900011400	2	Guarniz. metallica Ø 10.1X22X3	<i>Metal gasket Ø 10.1X22X3</i>	Joint métallique Ø 10.1X22X3	<i>Metalldichtung Ø 10.1X22X3</i>	Junta metálica Ø 10.1X22X3
19	M91800003400	2	Dado flangiato M10X1.25 cl.8.8	<i>Flanged nut M10X1.25 cl.8.8</i>	Ecrou bridé M10X1.25 cl.8.8	<i>Flanschmutter M10X1.25 cl.8.8</i>	Tuerca embreado M10X1.25 cl.8.8
20	M96600002400	4	Tappo contenimento olio	<i>Oil plug</i>	Bouchon huile	<i>Öbehälterdeckel</i>	Tapón contención aceite
21	M97600026400	4	Vite Torx M6X85	<i>Torx screw M6X85</i>	Vis Torx M6X85	<i>Torx-Schraube M6X85</i>	Tornillo Torx M6X85
22	M97600029400	12	Vite Torx M10X100X1,25	<i>Torx screw M10X100X1.25</i>	Vis Torx M10X100X1,25	<i>Torx-Schraube M10X100X1,25</i>	Tornillo Torx M10X100X1,25
23	M95000024400	12	Rondella	<i>Washer</i>	Rondelle	<i>Unterlegscheibe</i>	Arandela
24	M92900016400	2	Guarnizione testa	<i>Head gasket</i>	Joint de culasse	<i>Dichtung Kopfstück</i>	Junta culata
25	M91500009400	2	Coperchio testa	<i>Head cover guard</i>	Couvercle de culasse	<i>Abdeckung Kopfstück</i>	Tapa culata
26	M1613020	8	Vite+gommino coperchio testa	<i>Screw+head cover guard rubber cap</i>	Vis + joint en caoutchouc couvercle culasse	<i>Schraube+Gummieinsatz Abdeckung Kopfstück</i>	Tornillo+goma tapa culata
27	M90300007400	4	Anello raschiavalvole	<i>Valve scraper ring</i>	Joint de la tige de soupape	<i>Ventilschaber Ring</i>	Anillo rasca válvulas
28	M1613071	2	Guarnizione coperchio testa	<i>Head cover guard gasket</i>	Joint couvercle culasse	<i>Dichtung Abdeckung Kopfstück</i>	Junta tapa culata
29	M92900008400	2	Guarnizione canotto candela	<i>Spark plug stem gasket</i>	Joint tube de bougie	<i>Dichtung Kerzenschaft</i>	Junta manguito bujía
30	M92900007400	2	Guarnizione tendicatena	<i>Chain tensioner gasket</i>	Joint tendeur de chaîne	<i>Dichtung Kettenspanner</i>	Junta tensacadena
31	M94200002400	1	Piastrina chiusura tendicatena	<i>Chain tensioner closing plate</i>	Plaque fermeture tendeur de chaîne	<i>Schließplättchen Kettenspanner</i>	Plaqueta cierre tensacadena
33	M96600006400	1	Tappo sensore ruota fonica	<i>Phonic wheel sensor cap</i>	Bouchon capteur roue phonique	<i>Sensordeckel phonisches Rad</i>	Tapón sensor ruota fónica
34	M90400002400	1	Anello O-Ring Ø 17.17X1.78 viton	<i>O-ring Ø 17.17X1.78 viton</i>	Joint torique Ø 17.17X1.78 viton	<i>O-Ring Ø 17.17X1.78 Viton</i>	Anillo O-Ring Ø 17.17X1.78 viton
35	M94200007400	1	Piastrina tubo blow-by	<i>Blow-by pipe plate</i>	Plaque tube blow-by	<i>Plättchen Blowby Rohr</i>	Plaqueta tubo blow-by
36	M97600016400	3	Vite torx M6X14	<i>Torx screw M6X14</i>	Vis torx M6X14	<i>Torx-Schraube M6X14</i>	Tornillo torx M6X14
38	270130	1	Tubo blow-by	<i>Blow-by pipe</i>	Tube blow-by	<i>Blowby Rohr</i>	Tubo blow-by
40	M97600003400	2	Vite M6X10	<i>Screw M6X10</i>	Vis M6X10	<i>Schraube M6X10</i>	Tornillo M6X10
41	M92900013400	2	Guarnizione in rame	<i>Copper gasket</i>	Joint en cuivre	<i>Kupferdichtung</i>	Junta de cobre
42	M95900003400	1	Kit guarnizioni gruppo termico	<i>Thermal unit set of gaskets</i>	Kit joints groupe thermique	<i>Dichtungsset Wärmegruppe</i>	Kit juntas grupo térmico
43	M90400015400	12	Anello OR 7.65X1.78	<i>O-ring 7.65X1.78</i>	Joint torique 7.65X1.78	<i>O-Ring 7.65X1.78</i>	Anillo OR 7.65X1.78
44	M141201140	2	Coperchio testa nero	<i>Head cover guard black</i>	Couvercle tête noire	<i>Abdeckung Kopfstück schwarz</i>	Tapa culata negra

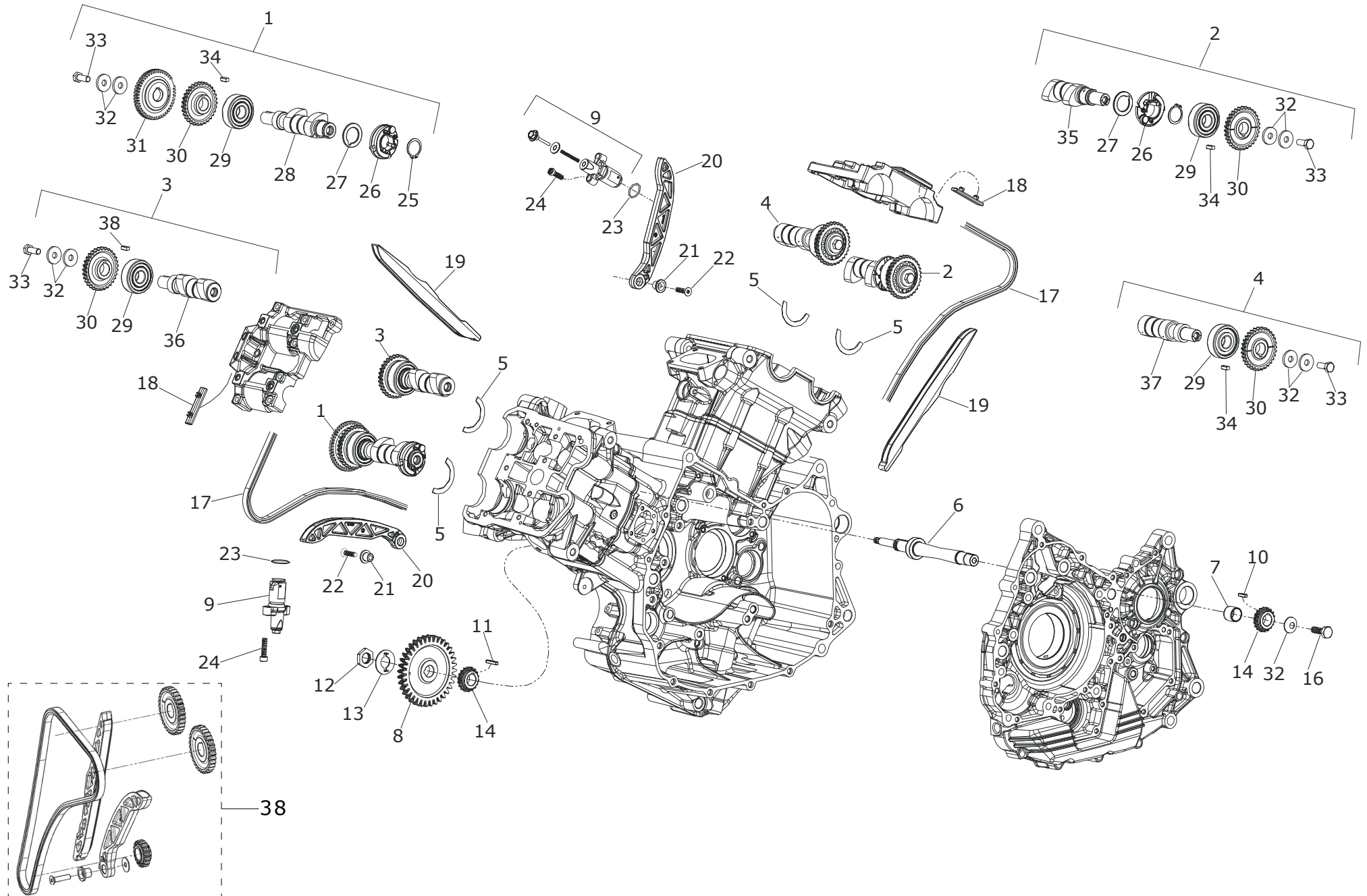

N°	Cod.	Q.	Descrizione	Description	Description	Beschreibung	Descripción
1	M90100016400	1	Albero camme compl. scar. ant.	<i>Complete front exhaust camshaft</i>	Arbre cames compl. échap. avant	<i>Nockenwelle komplett Vergaser vorne</i>	Eje de levas compl. esp. del.
2	M90100017400	1	Albero camme compl. scar. post.	<i>Complete rear exhaust camshaft</i>	Arbre cames compl. échap. arrière	<i>Nockenwelle komplett Vergaser hinten</i>	Eje de levas compl. esp. post.
3	M90100014400	1	Albero camme compl. asp. ant.	<i>Complete front intake camshaft</i>	Arbre cames compl. asp. avant	<i>Nockenwelle komplett Ansaugung vorne</i>	Eje de levas compl. esp. del.
4	M90100015400	1	Albero camme compl. asp. post.	<i>Complete rear intake camshaft</i>	Arbre cames compl. asp. arrière	<i>Nockenwelle komplett Ansaugung hinten</i>	Eje de levas compl. esp. post.
5	M95000011400	8	Rondella ondulata per camme	<i>Crinkle-washer camshaft</i>	Rondelle ond. pour cames	<i>Gewellte Unterlegscheibe für Nocken</i>	Arandela ond. para levas
6	M90200003400	1	Albero rinvio distribuzione	<i>Timing lay shaft</i>	Arbre de renvoi distribution	<i>Verteilerwelle</i>	Eje retorno distribución
7	M90500013400	1	Anello interno 17X20X16	<i>Inner ring 17X20X16</i>	Bague intér. 17X20X16	<i>Innenring 17X20X16</i>	Anillo interno 17X20X16
8	M93000011400	1	Ingran. comando distribuzione	<i>Timing control gear</i>	Engrenage commande distribution	<i>Antriebsrad Verteiler</i>	Ampl. mando distribución
9	M96700002400	2	Tendicatena completo	<i>Complete chain tensioner</i>	Tendeur de chaîne complet	<i>Kettenspanner komplett</i>	Tensacadena completo
10	M93600001400	1	Linguetta 5X4X13.5 lato volano	<i>Snap-on 5X4X13.5 flywheel side</i>	Languette 5X4X13.5 côté volant	<i>Zunge 5X4X13.5 Schwungrand</i>	Lengüeta 5X4X13.5 lado volante
11	M93600002400	1	Linguetta 5X4X25.5 lato frizione	<i>Snap-on 5X4X25.5 clutch side</i>	Languette 5X4X25.5 côté embrayage	<i>Zunge 5X4X25.5 Kupplung</i>	Lengüeta 5X4X25.5 lado embrague
12	M91800008400	1	Dado fissaggio rinvio	<i>Transmission fixing nut</i>	Ecrou de fixation renvoi	<i>Befestigungsmutter Umlenkrolle</i>	Tuerca fijación reenvío
13	M94200008400	1	Piastrino fermo dado	<i>Nut stop plate</i>	Plaque d'arrêt écrou	<i>Halteplättchen Mutter</i>	Plaqueta retén tuerca
14	M94300002400	2	Pignone catena distribuz. Z18	<i>Timing chain sprocket Z18</i>	Pignon chaîne de distribut. Z18	<i>Kettenantriebsrad Verteiler Z18</i>	Piñón cadena distribuc. Z18
16	M97600009400	1	Vite M8X18 cl. 10.9	<i>Screw M8x18 class 10.9</i>	Vis M8x18 cl. 10.9	<i>Schraube M8x18 cl. 10.9</i>	Tornillo M8x18 cl. 10.9
17	M91400001400	2	Catena distribuzione	<i>Timing chain</i>	Chaîne de distribution	<i>Verteilerkette</i>	Cadena de distribución
18	M94100001400	2	Pattino catena tra camme	<i>Chain sliding shoe in-between cams</i>	Patin de chaîne entre les cames	<i>Kettenschiene zwischen Nocken</i>	Patín cadena entre levas
19	M94100002400	2	Pattino fisso catena distribuzione	<i>Timing chain fixed shoe</i>	Patin fixe chaîne de distribution	<i>Feste Kettenschiene Verteiler</i>	Patín fijo cadena distribuc.
20	M94100003400	2	Pattino mobile catena distribuzione	<i>Timing chain mobile shoe</i>	Patin mobile chaîne de distribution	<i>Mobile Kettenschiene Verteiler</i>	Patín móvil cadena distribuc.
21	M90900005400	2	Boccola pattino catena	<i>Chain sliding shoe bushing</i>	Bague patin de chaîne	<i>Buchse Gleitschiene</i>	Casquillo patín cadena
22	M97600031400	2	Vite M6X25	<i>Screw M6X25</i>	Vis M6X25	<i>Schraube M6X25</i>	Tornillo M6X25
23	M90400012400	2	O-ring 2075 viton	<i>O-ring 2075 viton</i>	Joint torique 2075 viton	<i>O-Ring 2075 Viton</i>	O-ring 2075 viton
24	M97600019400	4	Vite Torx M6X25	<i>Torx screw M6X25</i>	Vis Torx M6X25	<i>Torx-Schraube M6X25</i>	Tornillo Torx M6X25
25	M90500007400	1	Anello seeger Ø 22e	<i>Circlip Ø 22e</i>	Circlip Ø 22e	<i>Seegerring Ø 22e</i>	Anillo seeger Ø 22e
26	M91900001400	2	Decompressore completo	<i>Complete relief device</i>	Décompresseur complet	<i>Verdichtungsminderer komplett</i>	Descompresor completo

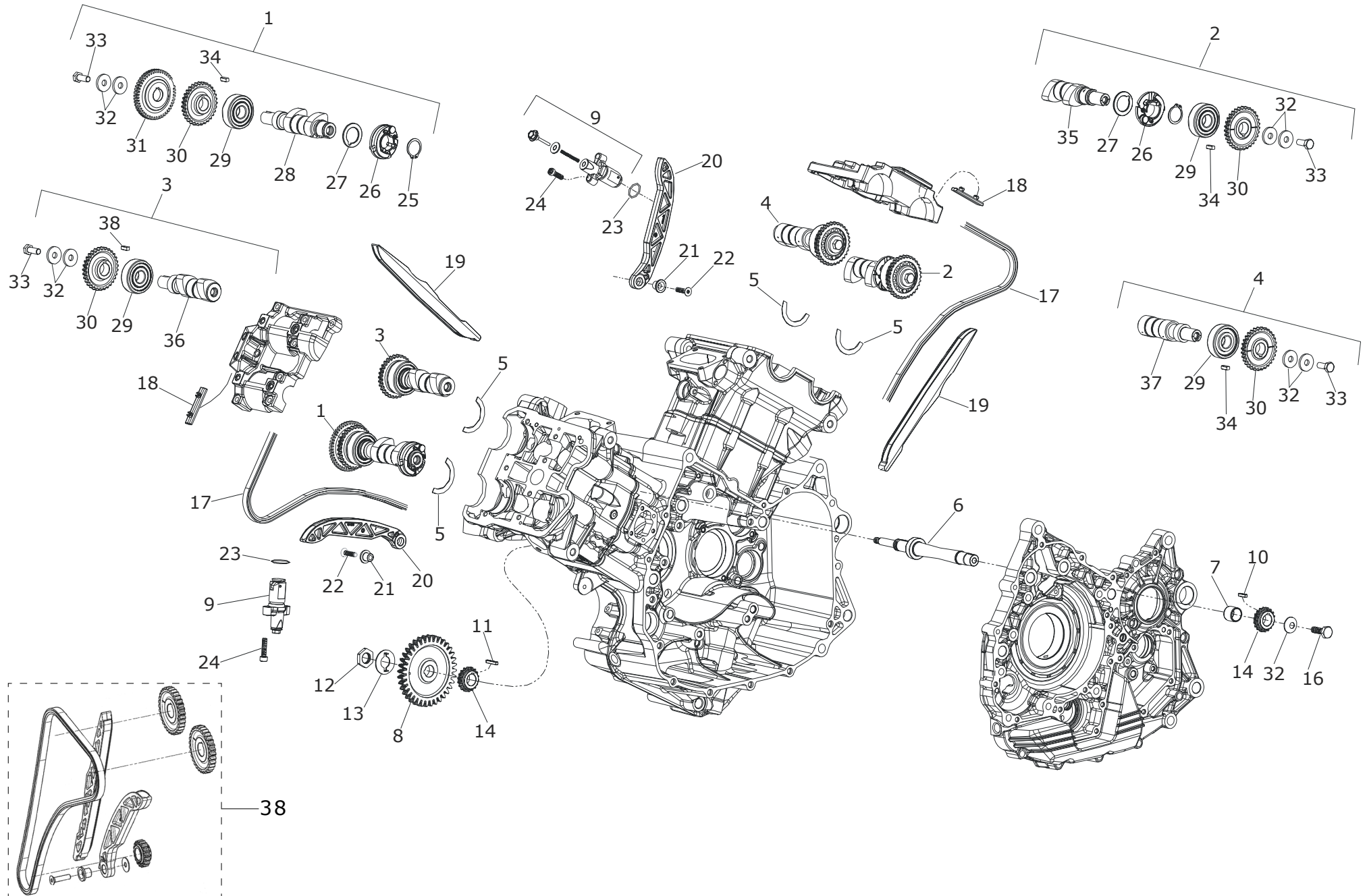



N°	Cod.	Q.	Descrizione	Description	Description	Beschreibung	Descripción
27	M92000005400	2	Distanziale decompressore	<i>Relief device spacer</i>	Entretoise décompresseur	<i>Distanzscheibe Verdichtungsminderer</i>	Distanciador descompresor
28	M90100012400	1	Albero camme scarico ant.	<i>Front exhaust camshaft</i>	Arbre cames échappement avant	<i>Nockenwelle Vergaser vorne</i>	Eje de levas descarga del.
29	M91700002400	4	Cuscinetto 17X47X14 2rs1 c3	<i>Bearing 17X47X14 2rs1 c3</i>	Roulement 17X47X14 2rs1 c3	<i>Lager 17X47X14 2rs1 c3</i>	Cojinete 17X47X14 2rs1 c3
30	M91600002400	4	Corona distribuzione	<i>Timing sprocket</i>	Couronne de distribution	<i>Verteilerkranz</i>	Corona distribución
31	M95200001400	1	Ruota fonica	<i>Phonic wheel</i>	Roue phonique	<i>Phonisches Rad</i>	Rueda fónica
32	M95000019400	9	Rosetta elastica Ø 8X24X3	<i>Snap ring Ø 8X24X3</i>	Rondelle élastique Ø 8X24X3	<i>Federrosette Ø 8X24X3</i>	Arandela elástica Ø 8X24X3
33	M97600010400	4	Vite TCEI M8X25	<i>Screw TCEI M8X25</i>	Vis TCEI M8X25	<i>Schraube TCEI M8X25</i>	Tornillo TCEI M8X25
34	M93600004400	4	Linguetta	<i>Snap-on</i>	Languette	<i>Zunge</i>	Lengüeta
35	M90100013400	1	Albero camme scarico post.	<i>Rear exhaust camshaft</i>	Arbre cames échappement arrière	<i>Nockenwelle Vergaser hinten</i>	Eje de levas descarga post.
36	M90100010400	1	Albero camme aspirazione ant.	<i>Front intake camshaft</i>	Arbre cames aspiration avant	<i>Nockenwelle Ansaugung vorne</i>	Eje de levas aspiración del.
37	M90100011400	1	Albero camme aspirazione post.	<i>Rear intake camshaft</i>	Arbre cames aspiration arrière	<i>Nockenwelle Ansaugung hinten</i>	Eje de levas aspiración post.
38	R1613010	1	Kit catena distribuzione	<i>Kit timing chain</i>	Kit chaîne distribution	<i>Set Verteilerkette</i>	Kit cadena de distribución

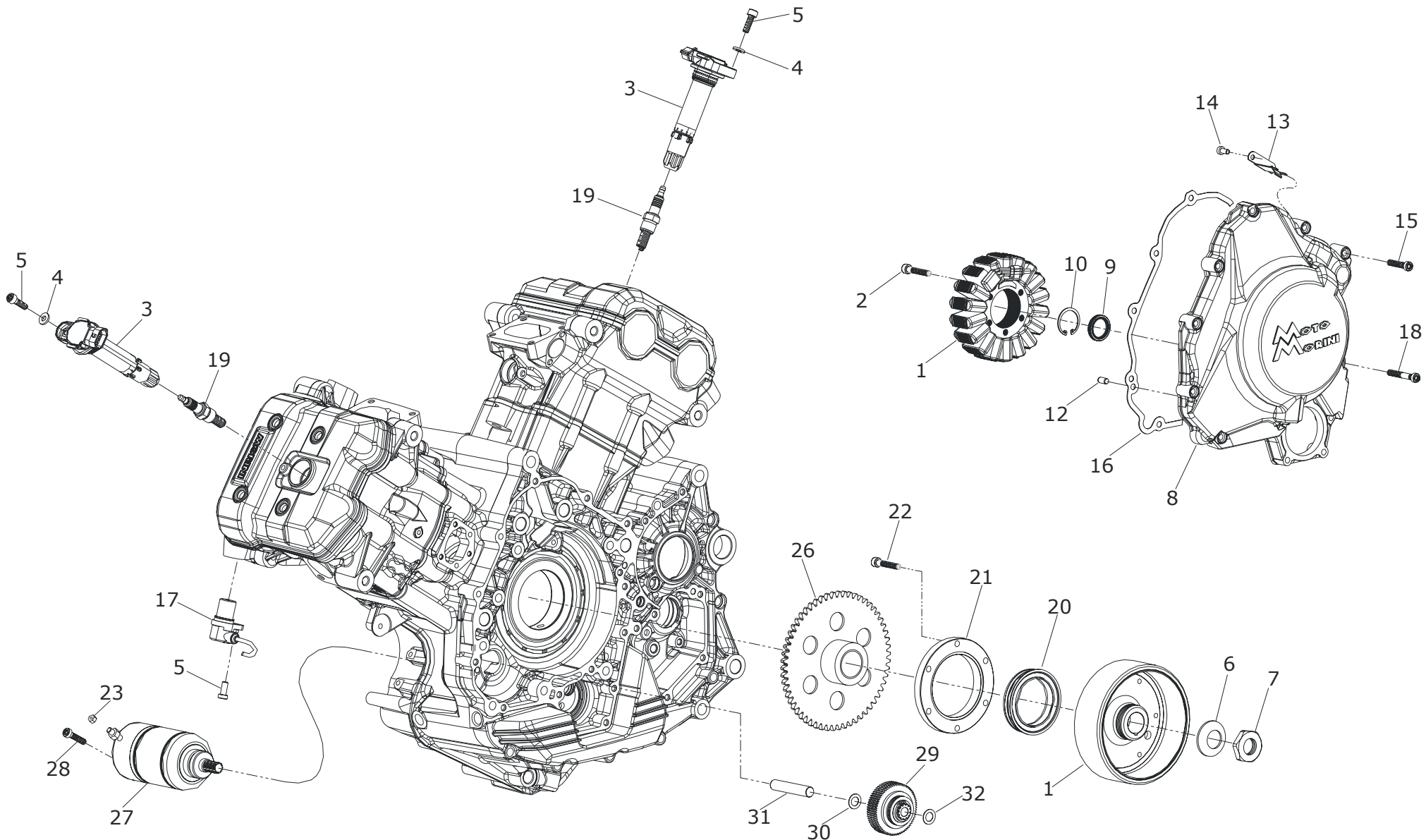



N°	Cod.	Q.	Descrizione	Description	Description	Beschreibung	Descripción
1	M1620010	1	Volano generatore	Alternator flywheel	Volant générateur	Antriebsschwungrad	Volante generador
2	M97600021400	3	Vite Torx M6X35	Torx screw M6X35	Vis Torx M6X35	Torx-Schraube M6X35	Tornillo Torx M6X35
3	M90800001400	2	Bobina stick coil	Stick coil	Bobine stick coil	Stickcoil Spule	Bobina stick coil
4	M95000010400	2	Rondella grower Ø 6	Grower washer Ø 6	Rondelle grower Ø 6	Grower Scheibe Ø 6	Arandela grower Ø 6
5	M97600016400	3	Vite Torx M6X14	Torx screw M6X14	Vis Torx M6X14	Torx-Schraube M6X14	Tornillo Torx M6X14
6	M93800005400	1	Molla tazza	Belleville washer	Ressort tasse	Spannscheibe	Arandela elástica
7	M91800004400	1	Dado M18X1.5	Nut M18X1.5	Ecrou M18X1,5	Mutter M18X1.5	Tuerca M18X1.5
8	M142001152	1	Coperchio volano nero + serigrafia bianca	Flywheel cover black + white serigraphy	Couvercle volant noire + sérigraphie blanche	Abdeckung Schwungrad schwarz + weisse Grafik	Tapa volante negra + gráfica blanca
9	M90300003400	1	Anello di tenuta tcv 16X28X7 viton	Seal ring tcv16X28X7 viton	Bague d'étanchéité tcv 16X28X7 viton	Dichtring tcv 16X28X7 Viton	An. de estanqueidad tcv16X28X7 viton
10	M90500010400	1	Anello seeger interno Ø 28	Inner circlip Ø 28	Circlip intérieur Ø 28	Seegerring innen Ø 28	Anillo seeger interno Ø 28
12	M96100003400	2	Spina cilindrica Ø 6X12	Cylindrical pin Ø 6X12	Goupille cylindrique Ø 6X12	Zylinderstift Ø 6X12	Clavija cilíndrica Ø 6X12
13	M94200004400	1	Piastrina fermo cavo	Cable stop plate	Plaque d'arrêt câble	Halteplättchen Kabel	Plaqueta retén cable
14	M97600004400	1	Vite M5X10	Screw M5X10	Vis M5X10	Schraube M5X10	Tornillo M5X10
15	M97600020400	9	Vite Torx M6X30	Torx screw M6X30	Vis Torx M6X30	Torx-Schraube M6X30	Tornillo Torx M6X30
16	M1620021	1	Guarnizione coperchio volano	Gasket flywheel cup	Joint couvercle volant	Dichtung Abdeckung Schwungrad	Junta tapa volante
17	M95800002400	1	Sensore giri	Rpm sensor	Capteur de tours	Drehzahlmesser	Sensor revoluciones
18	M97600024400	2	Vite Torx M6X55	Torx screw M6X55	Vis Torx M6X55	Torx-Schraube M6X55	Tornillo Torx M6X55
19	M2120011	2	Candela NGK CR9EB	Spark plug NGK CR9EB	Bougie NGK CR9EB	Kerze NGK CR9EB	Bujía NGK CR9EB
20	M95200002400	1	Ruota libera	Freewheel	Roue libre	Freilaufnabe	Rueda libre
21	M90500012400	1	Anello esterno per ruota libera	Freewheel outer ring	Bague extérieure pour roue libre	Außenring für Freilaufnabe	Anillo externo para rueda libre
22	M97600017400	6	Vite Torx M6X18	Torx screw M6X18	Vis Torx M6X18	Torx-Schraube M6X18	Tornillo Torx M6X18
23	M02000010401	1	Dado M6	M6 nut	Ecrou M6	Mutter M6	Tuerca M6
26	M1621010	1	Corona avviamento completa	Complete starter sprocket	Couronne démarrage complète	Anlasserkranz komplett	Corona arranque completa
27	M1621020	1	Motorino avviamento	Starter motor	Démarrreur	Anlasser	Motor arranque
28	M97600019400	2	Vite Torx M6X25	Torx screw M6X25	Vis Torx M6X25	Torx-Schraube M6X25	Tornillo Torx M6X25
29	M1621030	1	Rinvio motorino	Starter motor transmission	Renvoi démarreur	Anlasser Rücklauf	Retorno motor
30	M009900205	1	Rondella Ø 11X19X0,5	O-ring Ø 11X19X0.5	Rondelle Ø 11X19X0,5	Unterlegscheibe Ø 11X19X0,5	Arandela Ø 11X19X0,5
31	M96100001400	1	Spina cilindro rinvio	Cylindrical pin transmission	Goupille cylindre de renvoi	Zylinderstift	Clavija cilindro retorno
32	M009900203	1	Rondella Ø 11X19X0,3	O-ring Ø 11X19X0.3	Rondelle Ø 11X19X0,3	Unterlegscheibe Ø 11X19X0,3	Arandela Ø 11X19X0,3

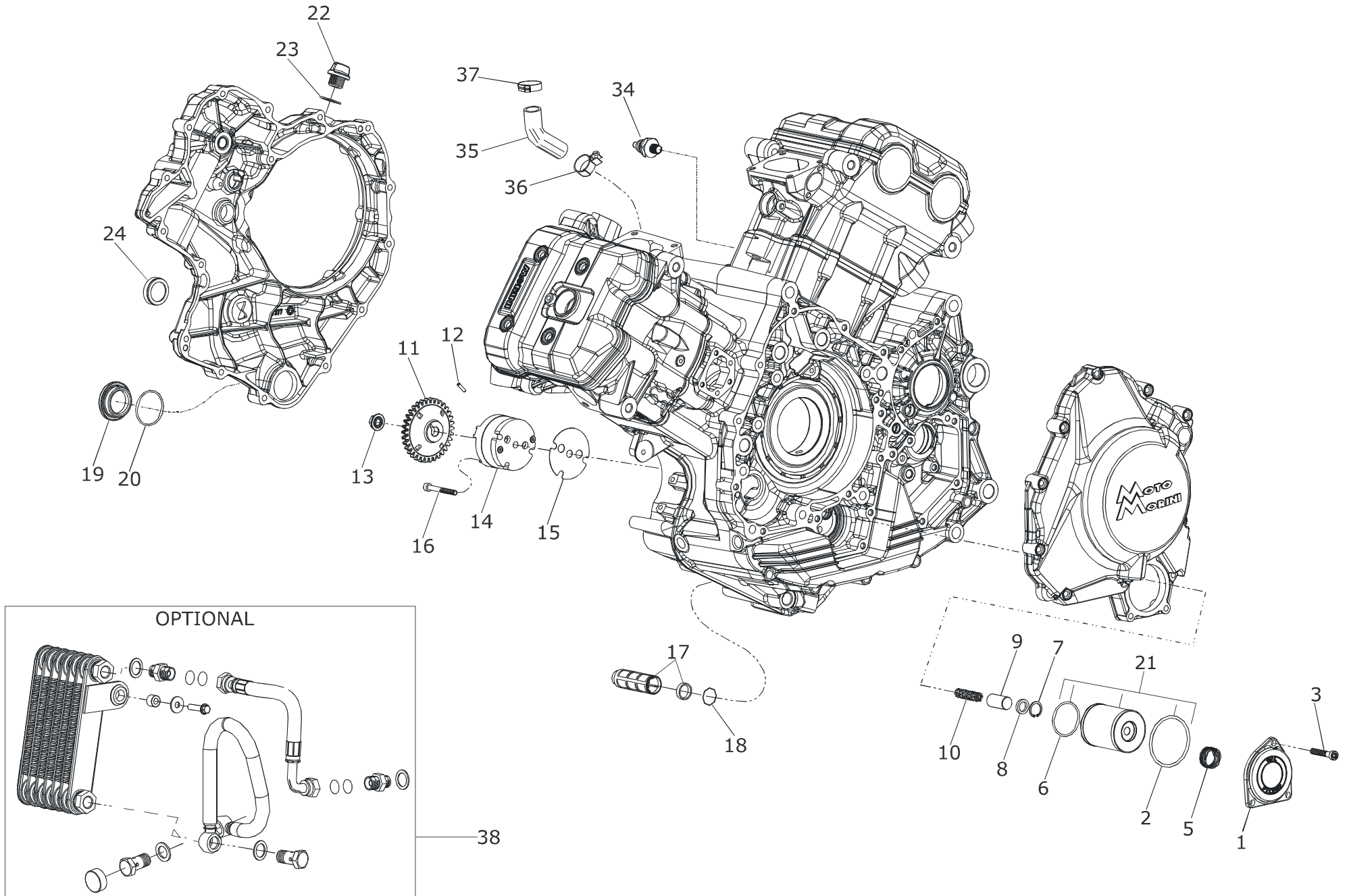



N°	Cod.	Q.	Descrizione	Description	Description	Beschreibung	Descripción
1	M141801140	1	Cop. filtro olio nero	<i>Oil filter plug black</i>	Couvercle filtre huile noir	<i>Abdeckung Ölfilter Schwarz</i>	Tapa filtro aceite negro
2	M90400007400	1	Anello O-ring Ø 55X3 viton	<i>O-ring Ø 55X3 viton</i>	Anneau O-ring Ø 55X3 viton	<i>O-Ring Ø 55X3 viton</i>	Anillo O-ring Ø 55X3 viton
3	M97600022400	3	Vite torx M6X40	<i>Torx screw M6X40</i>	Vis torx M6X40	<i>Torx-Schraube M6X40</i>	Tornillo torx M6X40
5	M93800002400	1	Molla filtro cartuccia olio	<i>Oil filter cartridge spring</i>	Ressort filtre cartouche huile	<i>Feder Ölpatronenfilter</i>	Muelle filtro cartucho aceite
6	M90400006400	1	Anello O-ring Ø 42X2.5	<i>O-ring Ø 42X2.5 viton</i>	Anneau O-ring Ø 42X2.5	<i>O-Ring Ø 42X2.5</i>	Anillo O-ring Ø 42X2.5
7	M90500006400	1	Anello seeger Ø 16 interno	<i>Inner circlip Ø 16</i>	Anneau seeger Ø 16 interne	<i>Seegerring Ø 16 innen</i>	Anillo seeger Ø 16 interno
8	M92000001400	1	Distanziale arresto valvola olio	<i>Oil valve stop spacer</i>	Entretoise arrêt soupape huile	<i>Distanzialstoppscheibe Ölventil</i>	Distanciador parada válvula aceite
9	M97500001400	1	Valvola regolaz. pressione olio	<i>Oil pressure adjusting valve</i>	Soupape réglage pression huile	<i>Reglerventil Öldruck</i>	Válvula regulac. presión aceite
10	M93800008400	1	Molla valvola pressione olio	<i>Oil pressure valve spring</i>	Ressort soupape pression huile	<i>Feder Öldruckventil</i>	Muelle válvula presión aceite
11	M93000013400	1	Ingranaggio pompa olio	<i>Oil pump gear</i>	Engrenage pompe huile	<i>Zahnrad Ölpumpe</i>	Engranaje bomba de aceite
12	M95100002400	1	Rullo Ø 3X13,8	<i>Roller Ø 3X13.8</i>	Rouleau Ø 3X13,8	<i>Rolle Ø 3X13,8</i>	Rodillo Ø 3X13,8
13	M91800006400	1	Dado serpres M8	<i>Nut M8</i>	Ecrou serpes M8	<i>Serpres Mutter M8</i>	Tuerca serpres M8
14	M94500001400	1	Pompa olio completa	<i>Complete oil pump</i>	Pompe huile complète	<i>Ölpumpe komplett</i>	Bomba aceite completa
15	M1618001	1	Guarnizione pompa olio	<i>Oil pump gasket</i>	Garniture pompe huile	<i>Dichtung Ölpumpe</i>	Junta bomba aceite
16	M97600005400	3	Vite M5X50	<i>Screw M5X50</i>	Vis M 5X50	<i>Schraube M5X50</i>	Tornillo M5X50
17	M92200004400	1	Filtro olio	<i>Oil filter</i>	Filtre huile	<i>Ölfilter</i>	Filtro aceite
18	M90400011400	1	Anello O-ring 0300-10 viton	<i>O-ring 0300-10 viton</i>	Anneau O-ring 0300-10 viton	<i>O-Ring 0300-10 Viton</i>	Anillo O-ring 0300-10 viton
19	M96600003400	1	Tappo filtro olio	<i>Oil filter plug</i>	Bouchon filtre huile	<i>Deckel Ölfilter</i>	Tapón filtro aceite
20	M90400005400	1	An. O-ring 2142 Ø 36,27X1,78 viton	<i>O-ring 2142 Ø 36.27X1.78 viton</i>	An. O-ring 2142 Ø 36,27X1,78 viton	<i>O-Ring 2142 Ø 36,27X1,78 Viton</i>	An. O-ring 2142 Ø 36,27X1,78 viton
21	M92200003400	1	Kit filtro con OR	<i>Kit oil filter + o-ring</i>	Kit filtre avec OR	<i>Filterset mit O-Ring</i>	Kit filtro con OR
22	M96600001400	1	Tappo carico olio	<i>Oil filler cap</i>	Bouchon chargement huile	<i>Öfülldeckel</i>	Tapón llenado aceite
23	M90400013400	1	O-ring 2162	<i>O-ring 2162</i>	O-ring 2162	<i>O-Ring 2162</i>	O-ring 2162
24	M96600007400	1	Oblò livello olio	<i>Oil sight glass</i>	Hublot niveau huile	<i>Schauglas Füllstand</i>	Ojo de buey nivel aceite
34	M91100001400	1	Bulbo pressione olio	<i>Oil pressure bulb</i>	Bulbe pression huile	<i>Öldruckkolben</i>	Bulbo presión aceite
35	M97300007400	1	Tubo sfiato carter	<i>Case bleed pipe</i>	Tube évent carter	<i>Ablassrohr Schutzgehäuse</i>	Tubo respiradero cárter
36	M92100006400	1	Fascetta stringitubo	<i>Hose clamp</i>	Bandelette de serrage	<i>Leitungsklemme</i>	Abrazadera de apriete tubo
37	M92100005400	1	Fascetta stringitubo	<i>Hose clamp</i>	Bandelette de serrage	<i>Leitungsklemme</i>	Abrazadera de apriete tubo
38	M94800003400	1	Kit radiatore olio	<i>Kit oil cooler</i>	Kit radiateur huile	<i>Set Ölkühler</i>	Kit radiador aceite



GRANPASSO
1200

**Raffreddamento - Cooling system - Refroidissement
Kühlung - Refrigeración**

024

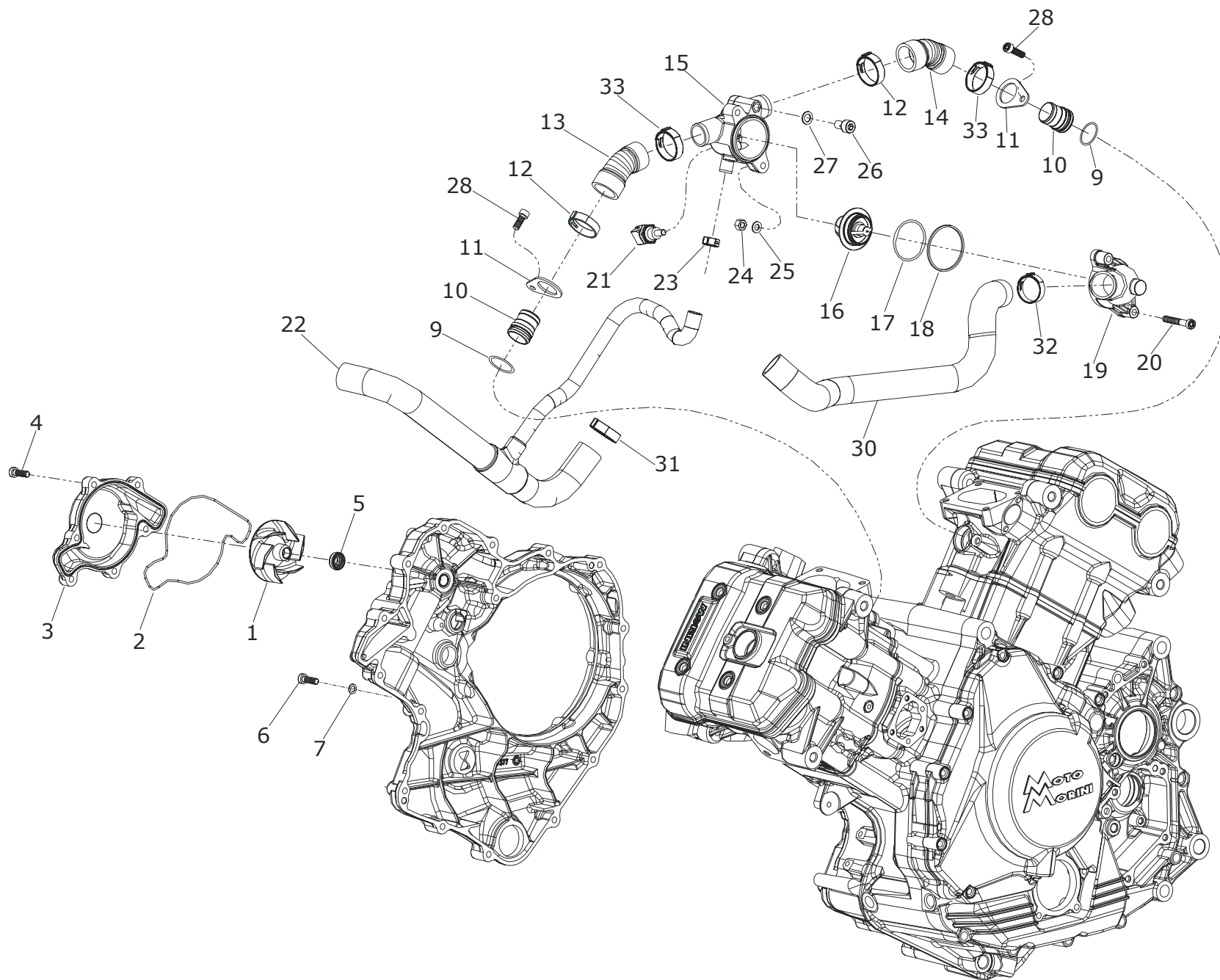

N°	Cod.	Q.	Descrizione	Description	Description	Beschreibung	Descripción
1	M92500001400	1	Girante pompa acqua	<i>Water pump impeller</i>	Rotor pompe à eau	<i>Umwälzrad Wasserpumpe</i>	Rotor bomba agua
2	M92900009400	1	Guarniz. coperchio pompa acqua	<i>Water pump cap gasket</i>	Joint couvercle pompe à eau	<i>Dichtung Abdeckung Wasserpumpe</i>	Junta tapa bomba agua
3	M141701140	1	Cop. pompa acqua nero	<i>Black water pump cover</i>	Prot. pompe eau noire	<i>Deckel Wasserpumpe schwarz</i>	Tapón bomba de agua negro
4	M97600015400	6	Vite Torx M5X20	<i>Torx screw M5X20</i>	Vis Torx M5X20	<i>Torx-Schraube M5X20</i>	Tornillo Torx M5X20
5	M90300005400	1	Anello tenuta baduo 10-18-5/8	<i>Baduo seal ring 10-18-5/8</i>	Bague d'étanchéité 10-18-5/8	<i>Baduo Dichtringbaduo 10-18-5/8</i>	Anillo de estanqueidad baduo 10-18-5/8
6	M97600003400	1	Vite M6X10	<i>Screw M6X10</i>	Vis M 6X10	<i>Schraube M6X10</i>	Tornillo M6X10
7	M92900013400	2	Guarnizione in rame	<i>Copper gasket</i>	Joint en cuivre	<i>Kupferdichtung</i>	Junta de cobre
9	M90400004400	2	Anello O-ring Ø 21,95X1,78	<i>O-ring Ø 21.95X1.78</i>	Joint torique Ø 21,95X1,78	<i>O-Ring Ø 21,95X1,78</i>	Anillo O-ring Ø 21,95X1,78
10	M94700001400	2	Raccordo acqua testa	<i>Head water connector</i>	Raccord eau culasse	<i>Wasseranschluss Kopfstück</i>	Racor agua culata
11	M94200005400	2	Piastrina fissaggio raccordo	<i>Connector fixing plate</i>	Plaque de fixation raccord	<i>Befestigungsplättchen Anschluss</i>	Plaqueta fijación racor
12	M92100003400	2	Fascetta 031,6-906r	<i>Hose clamp 031.6-906r</i>	Collier 031,6-906r	<i>Klemme 031,6-906r</i>	Abrazadera 031,6-906r
13	M1617001	1	Tubo acqua testa anteriore	<i>Front head water hose</i>	Tube eau culasse avant	<i>Wasserleitung Kopfstück vorne</i>	Tubo acqua culata delantera
14	M1617002	1	Tubo acqua testa posteriore	<i>Rear head water hose</i>	Tube eau culasse arrière	<i>Wasserleitung Kopfstück hinten</i>	Tubo acqua culata posterior
15	M91500011400	1	Corpo valvola termostato	<i>Thermal expansion valve accordobody</i>	Corps soupape thermostat	<i>Gehäuse Thermostatventil</i>	Cuerpo válvula termostato
16	M96900001400	1	Termostato	<i>Thermostat</i>	Thermostat	<i>Thermostat</i>	Termostato
17	M90400008400	1	Anello O-ring Ø 39X2	<i>O-ring Ø 39X2</i>	Joint torique Ø 39X2	<i>O-Ring Ø 39X2</i>	Anillo O-ring Ø 39X2
18	M90400009400	1	Anello O-ring	<i>O-ring</i>	Joint torique	<i>O-Ring</i>	Anillo O-ring
19	M91500010400	1	Coperchio valvola termostatica	<i>Thermal expansion valve cap</i>	Couvercle soupape thermostatique	<i>Deckel Thermostatventil</i>	Tapa válvula termostática
20	M97600022400	2	Vite Torx M6x40	<i>Torx screw M6X40</i>	Vis Torx M6X40	<i>Torx-Schraube M6X40</i>	Tornillo Torx M6X40
21	M95800001400	1	Sensore acqua	<i>Water sensor</i>	Capteur eau	<i>Wassersensor</i>	Sensor acqua
22	M97300008400	1	Tubo acqua dx	<i>Right water hose</i>	Tube eau dt	<i>Wasserleitung rechts</i>	Tubo acqua der.
23	M92100002400	1	Fascetta 018,0-706r	<i>Hose clamp 018.0-706r</i>	Collier 018,0-706r	<i>Klemme 018,0-706r</i>	Abrazadera 018,0-706r
24	M91800005400	2	Dado M6 H6 cl. 8	<i>Nut M6 H6 class 8</i>	Ecrou M6 H6 cl. 8	<i>Mutter M6 H6 cl. 8</i>	Tuerca M6 H6 cl. 8
25	M95000008400	2	Rondella bisellata Ø 6	<i>Chamfered washer Ø 6</i>	Rondelle biseautée Ø 6	<i>Schubunterlegscheibe Ø 6</i>	Arandela biselada Ø 6
26	M97600002400	1	Vite spurgo	<i>Relief screw</i>	Vis de purge	<i>Ablassventil</i>	Tornillo purga
27	M92900015400	1	Guarnizione vite spurgo acqua	<i>Air bleed screw gasket</i>	Joint vis de purge eau	<i>Dichtung Wasserablassventil</i>	Junta tornillo purga agua
28	M97600016400	2	Vite Torx M6X14	<i>Torx screw M6X14</i>	Vis Torx M6X14	<i>Torx-Schraube M6X14</i>	Tornillo Torx M6X14
30	M97300009400	1	Tubo acqua sx	<i>Left water hose</i>	Tube eau gche	<i>Wasserleitung links</i>	Tubo acqua izq.
31	M92100007400	1	Fascetta clic 96-320	<i>Clic hose clamp 96-320</i>	Collier clic 96-320	<i>Klemme 96-320</i>	Abrazadera clic 96-320
32	M92100009400	1	Fascetta clic 96-335	<i>Clic hose clamp 96-335</i>	Collier clic 96-335	<i>Klemme 96-335</i>	Abrazadera clic 96-335
33	M92100011400	2	Fascetta clic 86-260	<i>Clic hose clamp 86-260</i>	Collier clic 86-260	<i>Umwälzrad Wasserpumpe</i>	Abrazadera clic 86-260

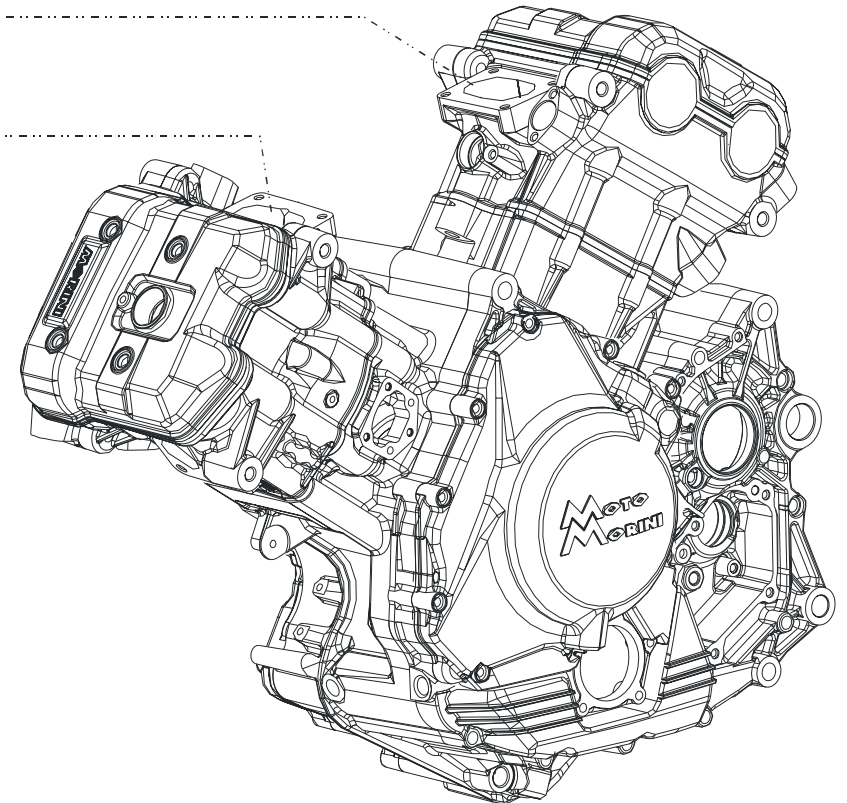
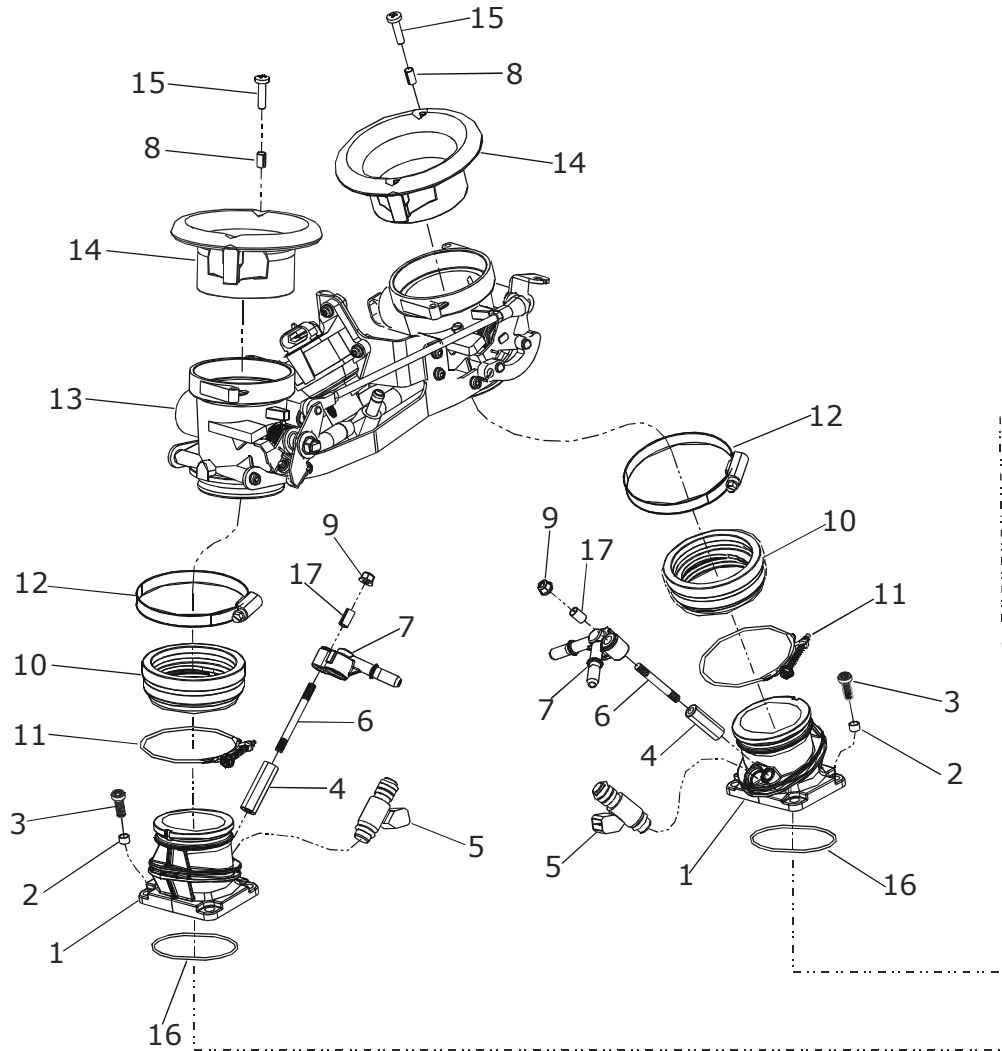

N°	Cod.	Q.	Descrizione	Description	Description	Beschreibung	Descripción
1	M94700002400	2	Raccordo aspirazione	<i>Intake connector</i>	Raccord d'aspiration	<i>Sauganschluss</i>	Racor aspiración
2	M91000002400	8	Bussola per raccordo aspirazione	<i>Intake connector bushing</i>	Bague pour raccord d'aspiration	<i>Buchse für Sauganschluss</i>	Casquillo para racor aspiración
3	M97600017400	8	Vite Torx M6X18	<i>Torx screw M6X18</i>	Vis Torx M6X18	<i>Torx-Schraube M6X18</i>	Tornillo Torx M6X18
4	M92000007400	2	Distanziale	<i>Spacer</i>	Entretoise	<i>Distanzialscheibe</i>	Distanciador
5	M93100001400	2	Iniettore	<i>Injector</i>	Injecteur	<i>Einspritzer</i>	Inyector
6	M94600001400	2	Prigioniero M5X60	<i>Stud bolt M5X60</i>	Goujon M5X60	<i>Abdichthülse M5X60</i>	Tornillo prigionero M5X60
7	M94700003400	2	Raccordo benzina	<i>Fuel connector</i>	Raccord essence	<i>Benzinschluss</i>	Racor gasolina
8	M92600001400	4	Grano elastico Ø7	<i>Spring dowel Ø7</i>	Vis élastique Ø7	<i>Federkorn Ø7</i>	Tornillo sin cabeza elástico Ø7
9	M91800001400	2	Dado autobloccante M5	<i>Self-locking nut M5</i>	Ecrou autobloquant M5 de sécurité	<i>Selbstsperrende Mutter M5</i>	Tuerca autobloccante M5
10	M93700001400	2	Manicotto corpo farfallato	<i>Throttle body hose</i>	Manchon corps papillon	<i>Muffe Drosselventil</i>	Manguito cuerpo de mariposa
11	M92100001400	2	Fascetta a filo Ø 58-65	<i>Wire hose clamp Ø 58-65</i>	Collier fil Ø 58-65	<i>Drahtklemme Ø 58-65</i>	Abrazadera metálica Ø 58-65
12	M92100004400	2	Fascetta sm9cw3 Ø72	<i>Hose clamp sm9cw3 Ø72</i>	Collier sm9cw3 Ø72	<i>Klemme sm9cw3 Ø72</i>	Abrazadera sm9cw3 Ø72
13	M2119010	1	Corpo farfallato completo	<i>Complete throttle</i>	Vanne papillon complète	<i>Drosselklappenkörper komplett</i>	Cuerpo de mariposa completo
14	M97200001400	2	Trombetta d'aspirazione	<i>Intake air funnel</i>	Trompette d'aspiration	<i>Sauganschluss</i>	Trompeta de aspiración
15	M97600008400	4	Vite M5X20	<i>Screw M5X20</i>	Vis M5X20	<i>Schraube M5X20</i>	Tornillo M5X20
16	M90400010400	2	Anello O-ring 56.87X1.78 viton	<i>O-ring 56.87X1.78 viton</i>	Joint torique 56.87X1.78 viton	<i>O-Ring 56.87X1.78 Viton</i>	Anillo O-ring 56.87X1.78 viton
17	M90900007400	2	Boccola raccordo	<i>Bushing</i>	Bague raccord	<i>Anschlussbuchse</i>	Casquillo racor

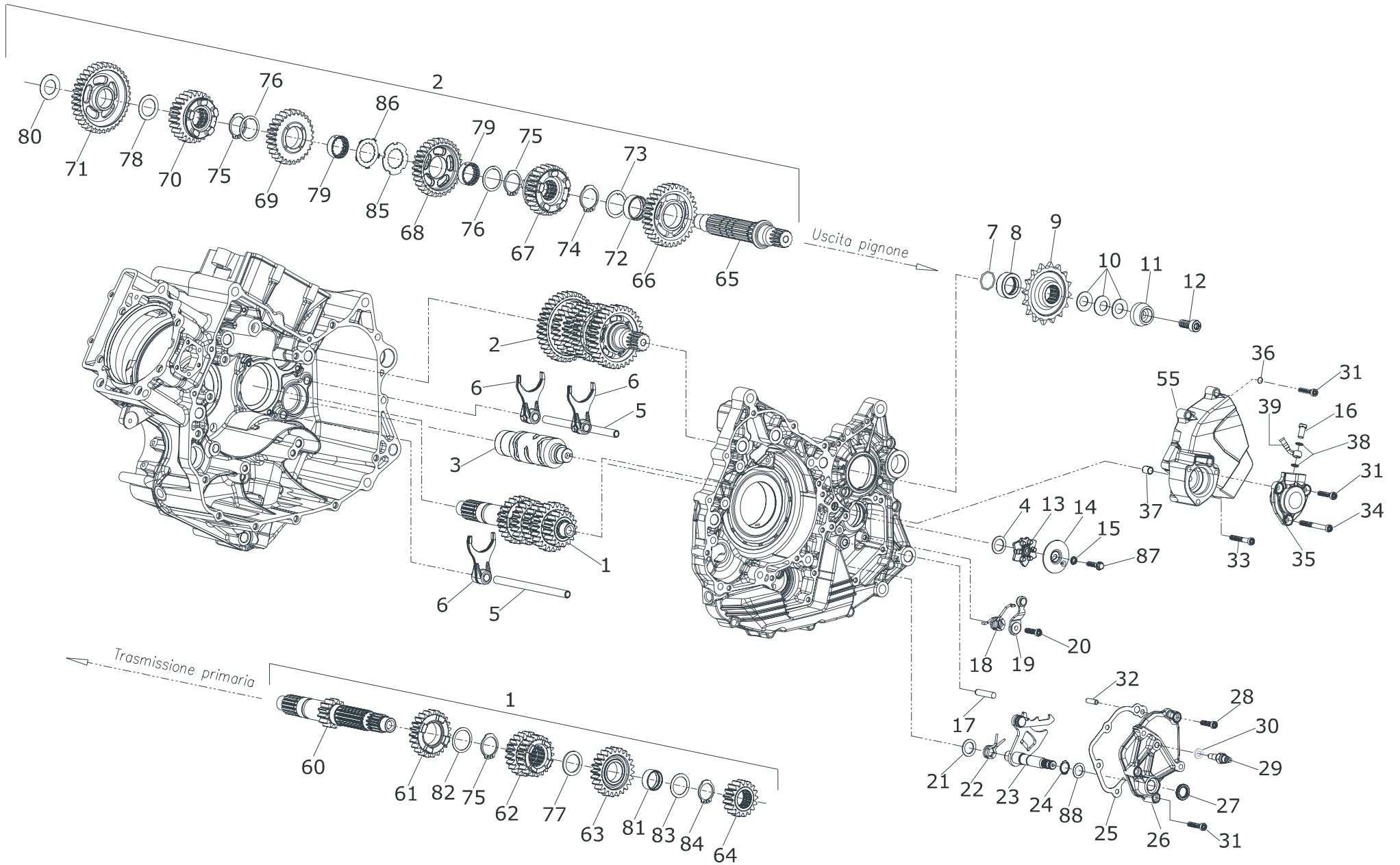

N°	Cod.	Q.	Descrizione	Description	Description	Beschreibung	Descripción
1	M90200005400	1	Albero primario completo	<i>Complete driving shaft</i>	Arbre primaire complet	<i>Hauptwelle komplett</i>	Eje primario completo
2	M90200006400	1	Albero secondario completo	<i>Complete transmission shaft</i>	Arbre secondaire complet	<i>Zweitwelle komplett</i>	Eje secundario completo
3	M90200001400	1	Albero desmodromico	<i>Desmodromic shaft</i>	Arbre desmodromique	<i>Desmo Welle</i>	Eje desmodrómico
4	M92000006400	1	Distanziale Ø26XØ20X2	<i>Spacer Ø 26XØ20X2</i>	Entretoise Ø26XØ20X2	<i>Distanzialscheibe Ø26XØ20X2</i>	Distanciadore Ø26XØ20X2
5	M90600002400	2	Asta forcella cambio	<i>Gear lever fork rod</i>	Axe fourche levier de vitesse	<i>Gabelstange Gangschaltung</i>	Varilla horquilla cambio
6	M92300001400	3	Forcella comando cambio	<i>Gear lever fork</i>	Fourche commande boîte de vitesses	<i>Schaltgabel</i>	Horquilla mando cambio
7	M90400003400	1	Anello or 2093 23.52X1.78 vit	<i>O-ring 2093 23.52X1.78 vit</i>	Joint torique 2093 23.52X1.78 vit	<i>O-Ring 2093 23.52X1.78 vit</i>	Anillo or 2093 23.52X1.78 vit
8	M92000008400	1	Distanziale porta O-ring	<i>O-ring spacer</i>	Entretoise porte-joint torique	<i>Distanzialscheibe Träger O-Ring</i>	Distanciadore porta O-ring
9	M94300001400	1	Pignone catena	<i>Front sprocket</i>	Pignon de chaîne	<i>Kettenantriebsrad</i>	Piñón cadena
10	M95000009400	3	Rosetta elastica Ø 16.3X31.5X2	<i>Snap ring Ø 16.3X31.5X2</i>	Rondelle elast. Ø 16.3X31.5X2	<i>Federrosette. Ø 16.3X31.5X2</i>	Arandela elast. Ø 16.3X31.5X2
11	M95000022400	1	Rosetta bloccaggio pignone	<i>Sprocket stop ring</i>	Rondelle d'arrêt pignon	<i>Blockierrosette Antriebsrad</i>	Arandela bloqueo piñón
12	M97600013400	1	Vite Torx M10X25	<i>Torx screw M10X25</i>	Vis Torx M10X25	<i>Torx-Schraube M10X25</i>	Tornillo Torx M10X25
13	M94200011400	1	Stella selettore	<i>Gearbox Y connection</i>	Etoile sélecteur	<i>Sternschalter</i>	Estrella selector
14	M94200009400	1	Piastrino sensore folle	<i>Neutral gear sensor plate</i>	Plaque capteur au point mort	<i>Plättchen Leerlaufsensor</i>	Plaqueta sensor loco
15	M95000010400	3	Rondella grower Ø 6	<i>Grower washer Ø 6</i>	Rondelle grower Ø 6	<i>Grower Unterlegscheibe Ø 6</i>	Arandela grower Ø 6
16	M01000003400	1	Vite forata	<i>Drilled screw</i>	Vis trouée à trou	<i>Lochschraube</i>	Tornillo perforado
17	M96100002400	1	Spina cilindrica Ø 8X38	<i>Cylindrical pin Ø 8X38</i>	Goujon cylindrique Ø 8X38	<i>Zylinderstift Ø 8X38</i>	Clavija cilíndrica Ø 8X38
18	M93800001400	1	Molla fermo marce	<i>Gear retainer spring</i>	Ressort arrêt marche	<i>Haltefeder Gänge</i>	Muelle retén marchas
19	M93500001400	1	Levetta ferma marce	<i>Gear retainer lever</i>	Levier arrêt marche	<i>Haltehebel Gänge</i>	Palanca retén marchas
20	M97600017400	1	Vite Torx M6X18	<i>Torx screw M6X18</i>	Vis Torx M6X18	<i>Torx-Schraube M6X18</i>	Tornillo Torx M6X18
21	M95000013400	1	Rondella rasamento 14X22X0,8	<i>Shim 14X22X0.8</i>	Rondelle arasement de butée 14X22X0,8	<i>Unterlegscheibe Ring 14X22X0,8</i>	Arandela nivelación 14X22X0,8
22	M93800003400	1	Molla richiamo piastra selettore	<i>Gearbox return spring</i>	Ressort de rappel plaque sélecteur	<i>Feder Schalterplättchen</i>	Muelle de ritorno placa selector
23	M94200001400	1	Piastra selettore completa	<i>Complete gearbox plate</i>	Plaque sélecteur complète	<i>Schalterplättchen komplett</i>	Placa selector completa
24	M90500002400	1	Anello seeg. Ø14 sp. 1,2	<i>Circlip Ø14 thick 1.2</i>	Joint torique Ø14 ep. 1,2	<i>Seegerring Ø14 sp.1,2</i>	Anillo seeg.Ø14 esp.1,2
25	M1616011	1	Guarnizione coperchio selettore	<i>Gearbox cover guard gasket</i>	Joint couvercle sélecteur	<i>Dichtung Schalterdeckel</i>	Junta tapa selector
26	M141601140	1	Coperchio selettore nero	<i>Black selector cover</i>	Couvercle sélecteur noir	<i>Deckel Wählschalter schwarz</i>	Tapa negra selector
27	M90300004400	1	Anello tenuta Ø 14X22X4	<i>Seal ring Ø 14X22X4</i>	Bague d'étanchéité Ø 14X22X4	<i>Dichtring Ø 14X22X4</i>	Anillo de estanqueidad Ø 14X22X4
28	M97600018400	1	Vite Torx M6X20	<i>Torx screw M6X20</i>	Vis Torx M6X20	<i>Torx-Schraube M6X20</i>	Tornillo Torx M6X20

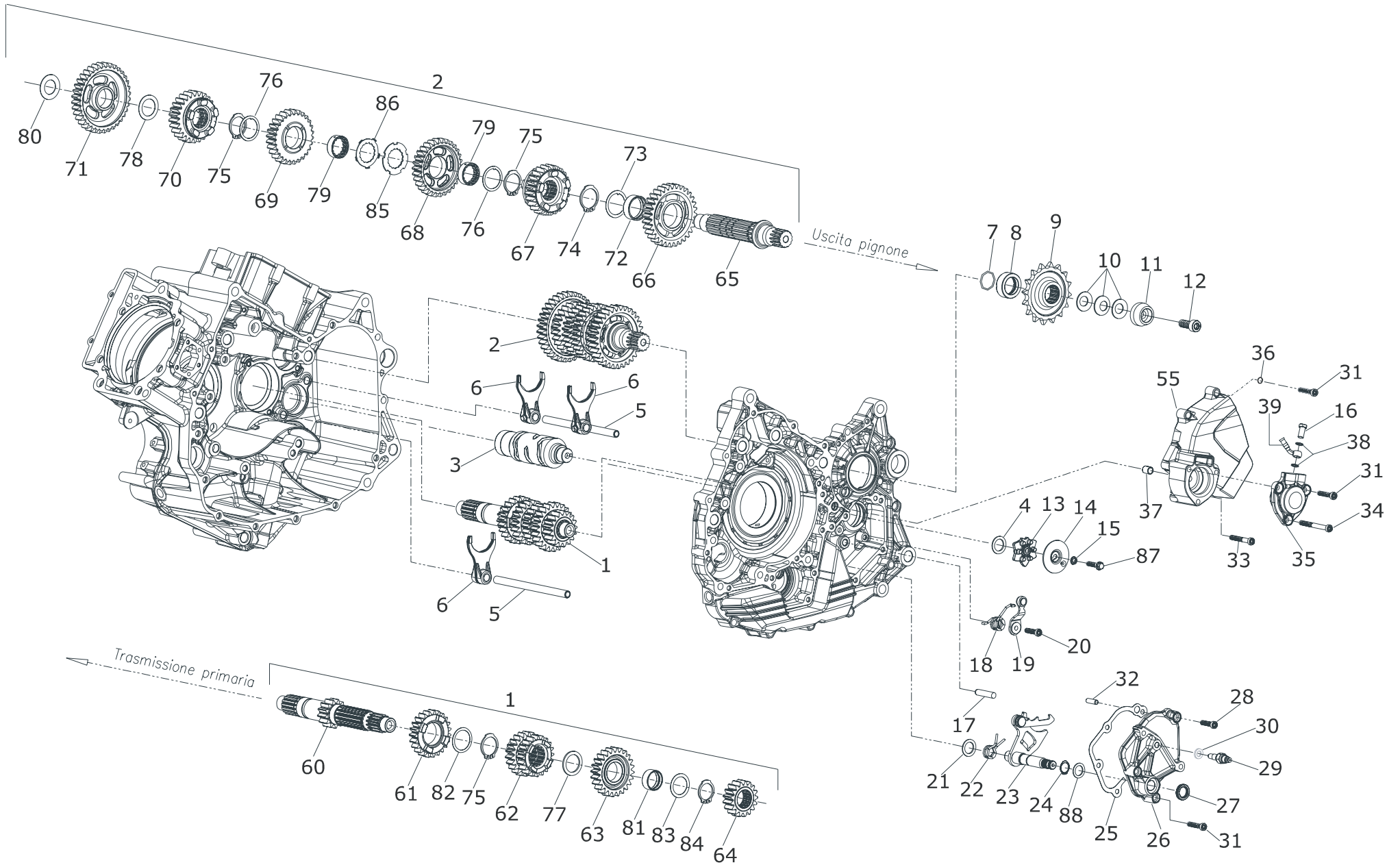

N°	Cod.	Q.	Descrizione	Description	Description	Beschreibung	Descripción
29	M93200001400	1	Interruttore folle	Idle speed control	Interrupteur point mort	Leerlaufschalter	Interruptor loco
30	M92900014400	1	Guarnizione interruttore folle	Neutral gear switch gasket	Joint interrupteur point mort	Dichtung Leerlaufschalter	Junta interruptor loco
31	M97600020400	3	Vite Torx M6X30	Torx screw MX30	Vis Torx M6X30	Torx-Schraube M6X30	Tornillo Torx M6X30
32	M96100003400	2	Spina cilindrica Ø 6X12	Cylindrical pin Ø 6X12	Goupille cylindrique Ø 6X12	Zylinderstift Ø 6X12	Clavija cilíndrica Ø 6X12
33	M97600023400	2	Vite Torx M6X45	Torx screw M6X45	Vis Torx M6X75	Torx-Schraube M6X45	Tornillo Torx M6X45
34	M97600025400	2	Vite Torx M6X75	Torx screw M6X75	Vis Torx M6X75	Torx-Schraube M6X75	Tornillo Torx M6X75
35	M92410003400	1	Cilindretto frizione	Clutch cylinder	Cylindre d'embrayage	Kupplungszyylinder	Cilindro embrague
36	M95000025400	3	Rondella 6.5X11.8X2	Washer 6.5X11.8X2	Rondelle 6.5X11.8X2	Unterlegscheibe 6.5X11.8X2	Arandela 6.5X11.8X2
37	M90900006400	1	Boccola permaglidle 0812	Permaglide bushing 0812	Bague Permaglide 0812	Permaglide Buchse 0812	Casquillo 0812
38	M03000002400	2	Rondella raccordo freni	Brake line fitting washer	Rondelle raccord freins	Anschlussscheibe Bremse	Arandela racor frenos
39	M50500003400	1	Trasmissione frizione	Clutch transmission	Transmission embrayage	Kupplungsantrieb	Transmisión embrague
55	M143601240	1	Coperchio pignone catena, nero	Black chain sprocket cover	Couvercle pignon de chaîne, noir	Deckel Kettenritzel schwarz	Tapa negra piñón de cadena
60	M90200002400	1	Albero cambio primario	Gearbox driving shaft	Boîte de vitesses primaire	Hauptschaltwelle	Árbol cambio primario
61	M93000003400	1	Ingranaggio 5a sul primario	5th gear on the driving shaft	Engrenage 5e sur primaire	Antriebsrad 5. Gang auf Hauptwelle	Engranaje 5a en el primario
62	M93000002400	1	Ingranaggio scorr. 3-4	3rd-4th gear sliding gears	Baladeur 3-4	Schieberad 3-4	Engranaje desplaz. 3-4
63	M93000004400	1	Ingranaggio 6a sul primario	6th gear on the driving shaft	Engrenage 6e sur primaire	Antriebsrad 6. Gang auf Hauptwelle	Engranaje 6a en el primario
64	M93000001400	1	Ingranaggio 2a sul primario	2nd gear on the driving shaft	Engrenage 2e sur primaire	Antriebsrad 2. Gang auf Hauptwelle	Engranaje 2a en el primario
65	M90200004400	1	Albero cambio secondario	Gearbox transmission haft	Boîte de vitesses secondaire	Zweitschaltwelle	Árbol cambio secundario
66	M93000006400	1	Ingranaggio 2a sul secondario	2nd gear on the transm. shaft	Engrenage 2e sur secondaire	Antriebsrad 2. Gang auf Zweitwelle	Engranaje 2a en el secundario
67	M93000010400	1	Ingranaggio scorrevole 6a sul secondario	6th gear sliding gears on the transmission shaft	Baladeur 6e sur secondaire	Antriebsrad 6. Gang auf Zweitwelle	Engranaje scorrevole 6a sul secondario
68	M93000007400	1	Ingranaggio 3a sul secondario	3rd gear on the transm. shaft	Engrenage 3e sur secondaire	Antriebsrad 3. Gang auf Zweitwelle	Engranaje 3a en el secundario
69	M93000008400	1	Ingranaggio 4a sul secondario	4th gear on the transm. shaf	Engrenage 4e sur secondaire	Antriebsrad 4. Gang auf Zweitwelle	Engranaje 4a en el secundario
70	M93000009400	1	Ingranaggio scorrevole 5a sul secondario	5th gear sliding gears on the transmission shaft	Baladeur 5e sur secondaire	Schieberad 5. Gang auf Zweitwelle	Engranaje scorrevole 5a sul secondario
71	M93000005400	1	Ingranaggio 1a sul secondario	1st gear on the transm. shaft	Engrenage 1e sur secondaire	Antriebsrad 1. Gang auf Zweitwelle	Engranaje 1a en el secundario
72	M90900002400	1	Boccola bimetallica 24X27X15	Bi-metal bushing 24X27X15	Bague bimétallique 24X27X15	Zweimetallbuchse 24X27X15	Casquillo bimetálico 24X27X15
73	M95000007400	1	Rasamento Ø 30X38X0.5	Shim Ø 30X38X0.5	Rosette de butée Ø 30X38X0.5	Ring Ø 30x38x0.5 Ø 30X38X0.5	Nivelación Ø 30X38X0.5

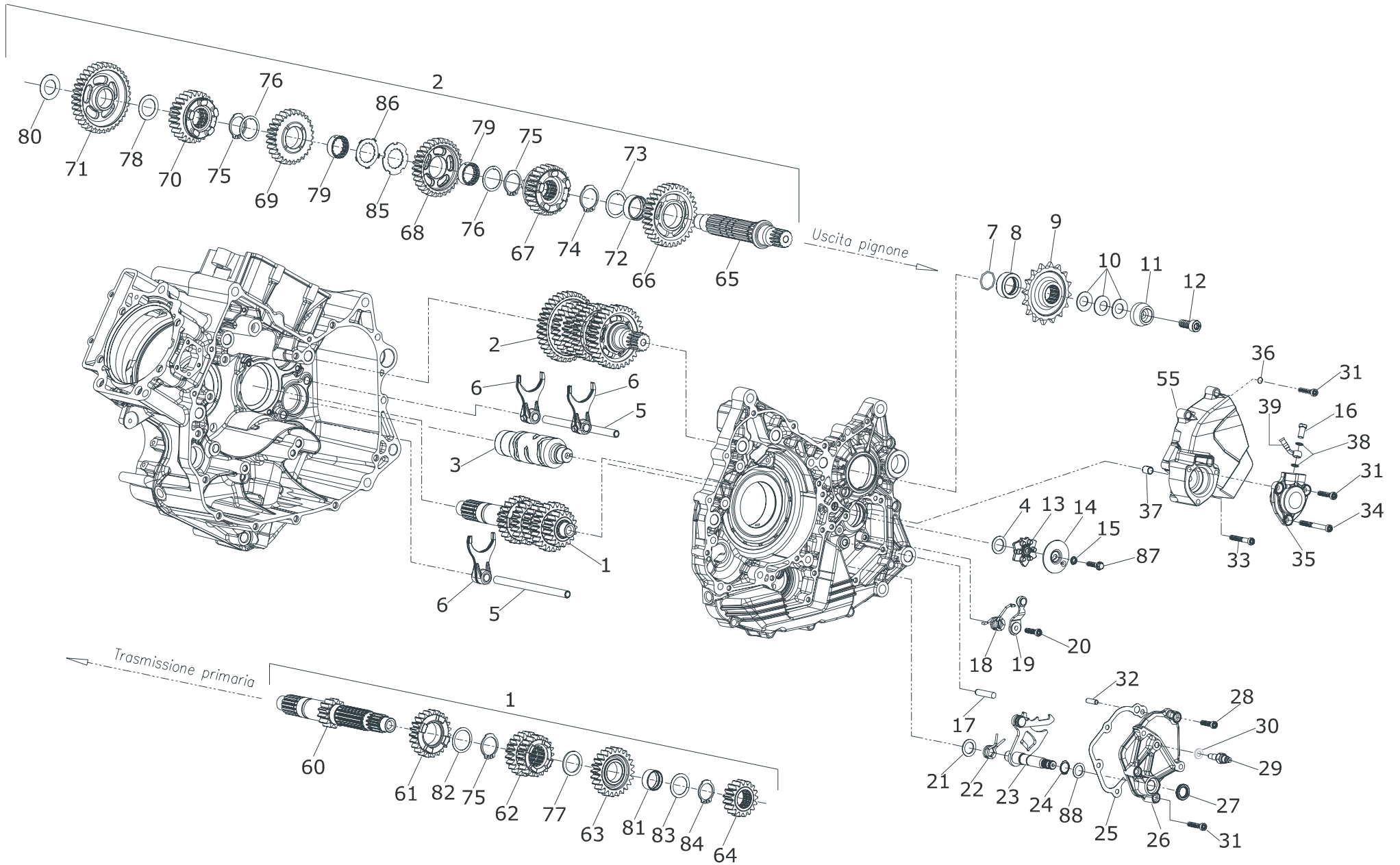



N°	Cod.	Q.	Descrizione	Description	Description	Beschreibung	Descripción
74	M90500005400	1	Anello seeger Ø 30	<i>Circlip Ø 30</i>	Circlip Ø 30	<i>Seegerring Ø 30</i>	Anillo seeger Ø 30
75	M90500009400	3	Anello seeger Ø 28	<i>Circlip Ø 28</i>	Circlip Ø 28	<i>Seegerring Ø 28</i>	Anillo seeger Ø 28
76	M95000001400	2	Rasamento brocciato 28X35X0.5	<i>Tapped shim 28X35X0.5</i>	Rosette de butée brochée 28X35X0.5	<i>Dornring 28X35X0.5</i>	Nivelación laminada 28X35X0.5
77	M95000005400	1	Rasamento Ø 25X34X2	<i>Shim Ø 25X34X2</i>	Rosette de butée Ø 25X34X2	<i>Ring Ø 25X34X2</i>	Nivelación Ø 25X34X2
78	M95000003400	1	Rasamento Ø 24X35X0.8	<i>Shim Ø 24X35X0.8</i>	Rosette de butée Ø 24X35X0.8	<i>Ring Ø 24X35X0.8</i>	Nivelación Ø 24X35X0.8
79	M90900003400	2	Boccola dentata	<i>Toothed bushing</i>	Bague dentée	<i>Zahnbuchse</i>	Casquillo dentado
80	M95000002400	1	Rasamento Ø 20X33X0.8	<i>Shim Ø 20X33X0.8</i>	Rosette de butée Ø 20X33X0.8	<i>Ring Ø 20X33X0.8</i>	Nivelación Ø 20X33X0.8
81	M90900004400	1	Boccola flottante per ingran.	<i>Gear floating bushing</i>	Bague flottante pour engrenage	<i>Buchse für Antriebsrad</i>	Casquillo flotante para engran.
82	M95000006400	1	Rasamento Ø 28X35X0.5	<i>Shim Ø 28X35X0.5</i>	Rosette de butée Ø 28X35X0.5	<i>Ring Ø 28X35X0.5</i>	Nivelación Ø 28X35X0.5
83	M95000004400	1	Rasamento Ø 25X34X0.5	<i>Shim Ø 25X34X0.5</i>	Rosette de butée Ø 25X34X0.5	<i>Ring Ø 25X34X0.5</i>	Nivelación Ø 25X34X0.5
84	M90500008400	1	Anello seeger Ø 25 400-3r	<i>Circlip Ø 25 400-3r</i>	Circlip Ø 25 400-3r	<i>Seegerring Ø 25 400-3r</i>	Anillo seeger Ø 25 400-3r
85	M90500011400	1	Anello brocciato 3a e 4a sul secondario	<i>3rd and 4th gear tapped ring on the transmission shaf</i>	Bague brochée 3e et 4e sur secondaire	<i>Dornring 3. und 4. Gang auf Zweitwelle</i>	Anillo laminado 3a y 4a en el secundario
86	M94200010400	1	Fermo anello rasam. brocciato	<i>Tapped shim stop ring</i>	Rosette de butée brochée	<i>Halterung Dornring</i>	Retén anillo laminado
87	M97600011400	1	Vite flangiata M6	<i>Flanged screw M6</i>	Vis bridée M6	<i>Flanschschraube M6</i>	Tornillo embridado M6
88	M009900306	1	Rasamento sp. 0,6	<i>0.6 thick shim</i>	Rosette de butée ép. 0,6	<i>Scheibe Dicke 0,6</i>	Arandela espesor 0,6

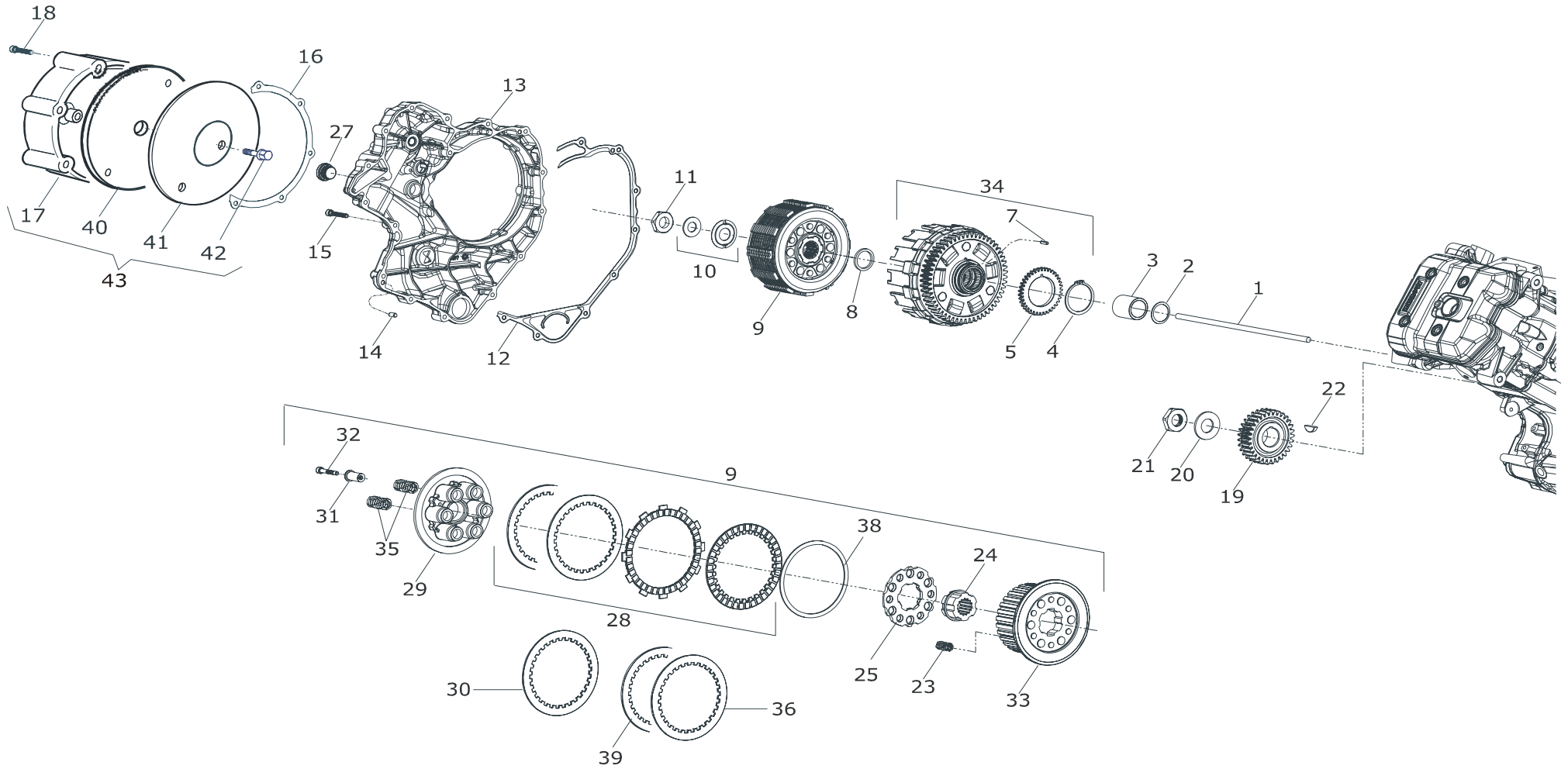



N°	Cod.	Q.	Descrizione	Description	Description	Beschreibung	Descripción
1	M90600001400	1	Asta comando frizione	<i>Clutch control rod</i>	Tige de commande embrayage	<i>Kupplungshebel</i>	Varilla mando embrague
2	M95000014400	1	Rondella rasam. Ø 28X47X1.5	<i>Shim ring Ø 28X47X1.5</i>	Rosette de butée Ø 28X47X1.5	<i>Unterlegscheibe Ring. Ø 28X47X1.5</i>	Arandela nivelac. Ø 28X47X1.5
3	M92000003400	1	Distanziale corona	<i>Sprocket spacer</i>	Entretoise couronne	<i>Distanzialscheibe Krone</i>	Distanciador corona
4	M90500003400	1	Anello seeg. ondulato Ø 48	<i>Crinkle circlip Ø 48</i>	Circlip ondulé Ø 48	<i>Gewellter Seegerring Ø 48</i>	Anillo seeg. ondulado Ø 48
5	M93000012400	1	Ingr. comando pompa olio	<i>Oil pump control gear</i>	Entrée comande pompe à huile	<i>Steuerzahnrad Ölpumpe</i>	Engr. mando bomba aceite
7	M95100001400	1	Rullino Ø 4X13,8	<i>Roller Ø 4X13.8</i>	Aiguille de roulement Ø 4X13,8	<i>Nadel Ø 4X13,8</i>	Rodillo Ø 4X13,8
8	M92000004400	1	Distanziale Ø 50X27.6X3	<i>Spacer Ø 50X27.6X3</i>	Entretoise Ø 50X27.6X3	<i>Distanzialscheibe Ø 50X27.6X3</i>	Distanciador Ø 50X27.6X3
9	M1614030	1	Frizione completa	<i>Complete clutch</i>	Embrayage complet	<i>Kupplung komplett</i>	Embrague completa
10	M93800011300	1	Piastrina ferma dado + rondella	<i>Nut stop plate + washer</i>	Plaque d'arrêt écrou + rondelle	<i>Halteplättchen Mutter + Unterlegscheibe</i>	Plaqueta retén tuerca + Arandela
11	M91800002400	1	Ghiera fissaggio tamburino	<i>Drum fixing ring nut</i>	Embout de fixation tambour	<i>Befestigungsring Trommel</i>	Virola de fijación tambor
12	M1614041	1	Guarn. coperchio trasmissione	<i>Transm. cover guard gasket</i>	Joint couvercle transmission	<i>Dichtung Abdeckung Antrieb</i>	Junta tapa transmisión
13	M141402140	1	Coperchio trasmissione	<i>Transmission cover guard</i>	Couvercle de transmission	<i>Abdeckung Antrieb</i>	Tapa transmisión
14	M96100003400	2	Spina cilindrica Ø 6X12	<i>Cylindrical pin Ø 6X12</i>	Goupille cylindrique Ø 6X12	<i>Zylinderstift Ø 6X12</i>	Clavija cilíndrica Ø 6X12
15	M97600020400	16	Vite Torx M6X30	<i>Torx screw M6X30</i>	Vis Torx M6X30	<i>Torx-Schraube M6X30</i>	Tornillo Torx M6X30
16	M1614051	1	Guarnizione coperchio frizione	<i>Clutch cover guard gasket</i>	Joint couvercle d'embrayage	<i>Dichtung Abdeckung Kupplung</i>	Junta tapa embrague
17	M141401152	1	Cop. frizione nero + serigrafia bianca	<i>Clutch cover black + white serigraphy</i>	Couvercle embrayage noir + sérigraphie blanche	<i>Kupplungsdeckel Schwarz + Serigrafie weiss</i>	Tapa de embrague negro + serigrafía blanca
18	M97600021400	7	Vite Torx M6X35	<i>Torx screw M6X35</i>	Vis Torx M6X35	<i>Torx-Schraube M6X35</i>	Tornillo Torx M6X35
19	M92800001400	1	Gruppo antibattito	<i>Anti-knock system</i>	Groupe anti-battement	<i>Schlagfang</i>	Grupo antigolpeteo
20	M93800007400	1	Molla tazza Ø 22.4X45X2.5	<i>Belleville washer Ø 22.4X45X2.5</i>	Rondelle Belleville Ø 22.4X45X2.5	<i>Spannscheibe Ø 22.4X45X2.5</i>	Arandela elástica Ø 22.4X45X2.5
21	M91800007400	1	Dado speciale M22X1	<i>Special nut M22X1</i>	Ecrou spécial M22X1	<i>Spezialmutter M22X1</i>	Tuerca especial M22X1
22	M93600003400	1	Linguetta a disco 8X9	<i>Disc snap-on 8X9</i>	Clavette sans serrage 8X9	<i>Federkeil 8X9</i>	Lengüeta a disco 8X9
23	M93800004400	6	Molla anti saltellamento	<i>Anti-hopping spring</i>	Amortisseur de secousses	<i>Anti-Hopping-Feder</i>	Muelle anti-hopping
24	M97100001400	1	Trascinatore anti-saltellamento	<i>Anti-hopping driver</i>	Entraînement anti-secousses	<i>Anti-Hopping-Mitnehmer</i>	Cubo anti-hopping
25	M94200003400	1	Piatto scorrevole	<i>Sliding plate</i>	Plaque coulissante	<i>Gleitteller</i>	Plato deslizante
27	M96600005400	1	Tappo registro fase	<i>Timing adjuster</i>	Bouchon pastille de réglage phase	<i>Deckel Phasenregister</i>	Tapón registro fase
28	R1614010	1	Serie dischi frizione radiale	<i>Set of radial clutch plates</i>	Jeu de disques d'embrayage radial	<i>Satz RadialKupplungsscheiben</i>	Serie discos embrague radial

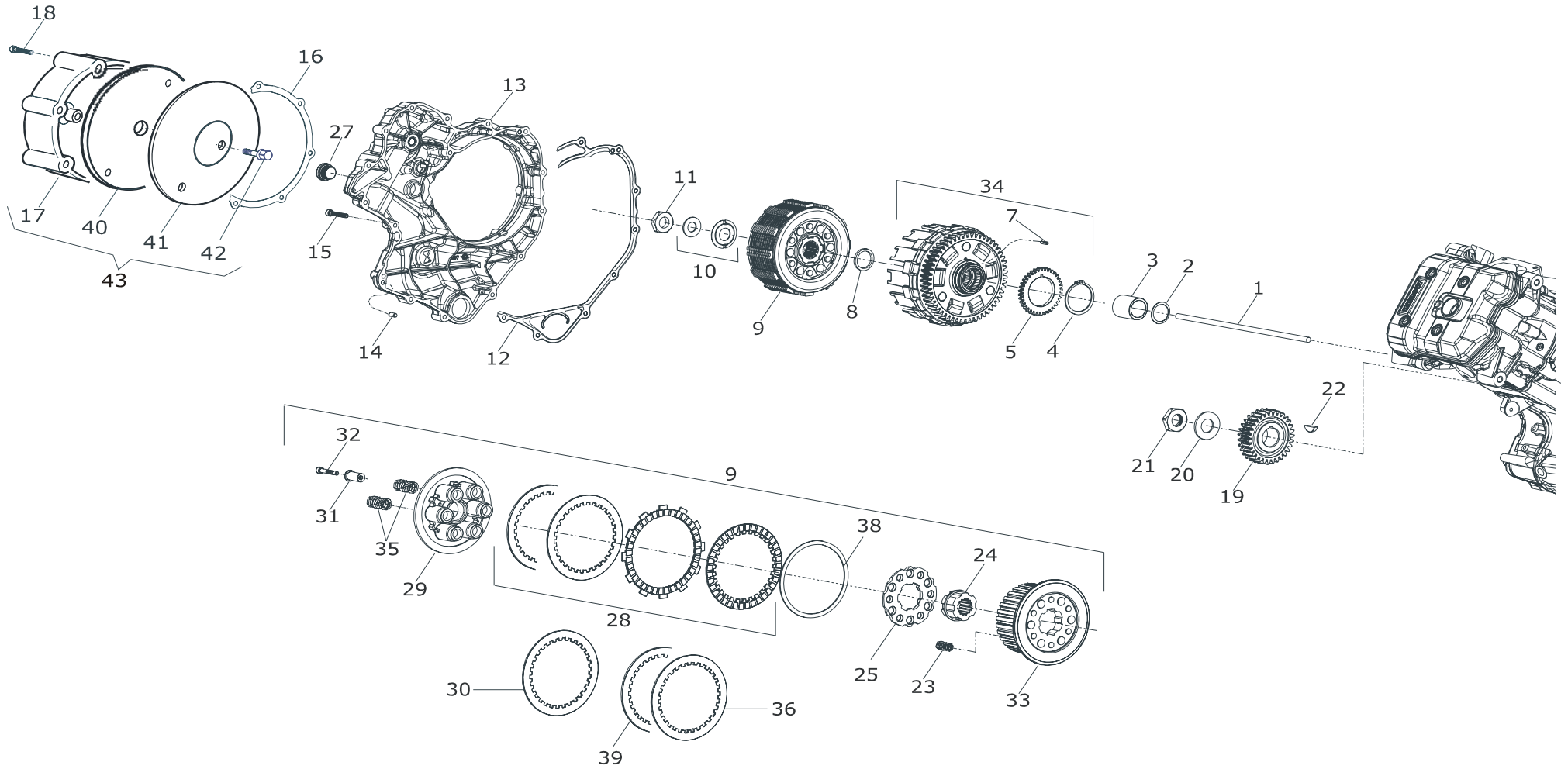



N°	Cod.	Q.	Descrizione	Description	Description	Beschreibung	Descripción
29	M1614010	1	Spingidisco frizione	<i>Clutch pressure plates</i>	Pousse-disque d'embrayage	<i>Antriebsscheibe Kupplung</i>	Empuje disco embrague
30	M92400006400	1	Disco frizione 2,5 mm	<i>Clutch disc 2.5 mm</i>	Disque d'embrayage 2,5 mm	<i>Kupplungsscheibe 2,5 mm</i>	Disco de embrague 2,5 mm
31	M90700002400	6	Bicchierino tenuta molla	<i>Spring retaining bowl</i>	Cloche d'étanchéité ressort	<i>Glocke Federdichtung</i>	Cazoleta de estanqueidad muelle
32	M97600007400	6	Vite M6X20 cl.12.9	<i>Screw M6X20 class 12.9</i>	Vis M6X20 cl.12.9	<i>Schraube M6X20 cl.12.9</i>	Tornillo M6X20 cl.12.9
33	M92400002400	1	Tamburino frizione	<i>Clutch drum</i>	Tambour d'embrayage	<i>Kupplungstrommel</i>	Tambor embrague
34	M97100002400	1	Trasmissione primaria	<i>Primary transmission</i>	Transmission primaire	<i>Hauptübertragung</i>	Transmisión primaria
35	M93300003400	6	Kit molle frizione	<i>Set of clutch springs</i>	Kit ressort d'embrayage	<i>Set Kupplungsfeder</i>	Kit muelles embrague
36	M92400005400	1	Disco frizione 2,0 mm	<i>Clutch disc 2.0 mm</i>	Disque d'embrayage 2,0 mm	<i>Kupplungsscheib 2,0 mm</i>	Disco de embrague 2,0 mm
38	M93300004400	1	Molla a tazza	<i>Belleville washer clutch</i>	Rondelle Belleville	<i>Spannscheibe</i>	Arandela elástica
39	M1614081	1	Disco ≠ 1,5	<i>Disc ≠ 1.5</i>	Disque ≠ 1,5	<i>Scheibe ≠ 1,5</i>	Disco ≠ 1,5
40	M1614061	1	Gomma fono assorbente	<i>Sound absorbing rubber</i>	Caoutchouc insonorisant	<i>Schalldämpfender Gummi</i>	Goma insonorizante
41	M1614071	1	Lamiera contrasto	<i>Plate</i>	Tôle de contraste	<i>Gegenplatte</i>	Contraplaca
42	M0056665	1	Vite TEF M6x12	<i>Teflon screw M6x12</i>	Vis TEF M6x12	<i>Teflonschraube M6x12</i>	Tornillo de teflón M6x12
43	M141401052	1	Coperchio frizione completo nero + serigrafia bianca	<i>Complete clutch cover, black + white serigraphy</i>	Couvercle embrayage complet, noir + sérigraphie blanche	<i>Kupplungsdeckel komplett, Schwarz + Serigrafie weiss</i>	Tapa de embrague completa, negro + serigrafía blanca



Moto Morini S.p.A.

Via Porrettana, 377 - 40033 Casalecchio di Reno (BO)

Tel. +39 51 19984162 - Fax +39 51 19984166

e-mail: info@motomorini.com

www.motomorini.com

M2144150